

Operating manual for Material pressure tanks DG 9 and DG 18



Read this manual carefully before installing, operating or servicing this equipment.
Keep always handy for further use.

ALFRED SCHÜTZE Apparatebau GmbH
- Spritztechnik – Spraytechnology -
Hannoversche Straße 69-71, 28309 Bremen – Germany;
Postfach 44 86 48, 28286 Bremen - Germany
Tel.: 0049 (0)421 / 43510-0; Fax: 0049 (0)421 / 43510-43
Internet: <http://www.schuetze-gmbh.de>
E-Mail: info@schuetze-gmbh.de

1 Introduction

The material pressure tank **DG 9** resp. **DG 18** is suitable for the output of fluids, f.i. colours, release agents or oils. In combination with a spray gun or an automatic spray valve fluids can be sprayed continuously in considerable volume. The increased output of fluid gives far more efficiency.

This material pressure tank is a precision tool. Please observe following instructions to maintain a long useful life.

2 Safety

2.1 Duties of the user

- The user must read this service manual carefully before performing any operations.
- Application and service operations should not be carried out if the user is not absolutely sure of the purpose and consequence of the operations.

2.2 Definitive Use

The pressure tank **DG 9** resp. **DG 18** is to be used in connection with a spray gun, when continuous spraying jobs suggest steady feeding of fluid to the gun. The tanks are made of aluminium.

Generally they are suitable for spraying materials. They are not suitable for spraying aggressive or headed materials. In case of doubt, contact the manufacturer.



Gases, fluidised gases, under pressure soluted gases, vapours and fluids, whose vapour Pressure at maximum allowed temperature is more than 0,5 bar higher as normal atmosphere pressure (1013mbar), are not at all allowed to use!

2.3 Warning against danger

This operating manual warns users of operations which may put their health at risk. The warnings are indicated by combinations of text and symbols corresponding to the different danger classes.

WARNING!

Signs a possible dangerous situation.
If you don't avoid, *death or severe injuries* can follow.

CAUTION!

Indicates a situation which may be dangerous.
Failure to heed the caution may result in *personal injury*. This indication is also used where material damage is possible.

IMPORTANT!

Indicates tips for usage and other helpful information.

3 Function Description

DG 9 stands for a pressure tank of 9 litre capacity, **DG 18** for 18 litres capacity. The outlets to the spray gun lead fluid (at max. 6 bar) and the atomizing air (at max. 6 bar) via hose (inner diameter Ø 4mm) to the gun.

Regulating of both pressures by means of the two respective reducing valves. The spray unit gives outstanding advantages in comparison to spray guns with mounted fluid cup:

- less spray interruption for refilling
- pressure feeding of spray material gives more throughput per unit of time
- weight of gun reduced by approx. 50%
- free handling of gun allows spraying in any position

On top of the tank all installations as reducing valves, safety valve and also air and fluid cocks are installed.

4 Opening operations

Please follow the undermentioned steps.

1. Open lid and pour spraying fluid into the tank. Close the lid properly.
2. Connect atomizing air outlet (17) via hose to spray gun.
3. Connect material outlet (17) via hose to spray gun.
4. Plug in air supply hose (from compressor or pressure line) at coupling nipple (6).
5. Open atomizing air cock (16) and fluid cock (16).
6. Regulate air pressure flowing into the tank at reducing valve knob (7) down to the minimum required to feed sufficient fluid volume to the gun. The atomizing air is to be regulated at the other reducing valve knob (7) in accordance with the required size of droplets. To reduce pressure turn knobs (7) anticlockwise until air escapes. To adjust to higher pressure turn knob (7) clockwise.
7. Start spraying by pulling trigger of gun. If necessary, re-adjust fluid feeding and atomizing air as per no. 6.
8. Previous to refilling the tank it is an Absolute requirement to evacuate the tank from any air pressure. Pull quick coupler off nipple (6)

4.2 Operating instructions



CAUTION!

Never point the spray guns against persons. Wearing eye protection is strongly recommended. Spraying procedures cause noises depending on the used pressure. If necessary wearing of ear protection is recommended.



WARNING!

Danger caused by combustible and noxious spraying material. Safety instructions on fluid can and material data of fluid manufacturer must definitely be observed.



IMPORTANT!

The pressure tank has to be secured in an upright position.

5 Repair and Maintenance

Before starting maintenance or repair work, ensure that all air operated tools are disconnected from the air supply.



WARNING!

Never try to unscrew the tank from the lid unless you have made sure, that air pressure has been evacuated completely

The pressure tank **DG 9** resp. **DG 18** is of sturdy quality. Unit has always to be kept clean. A minimum of effort ensures a long useful life. The tank is largely maintenance-free. It is recommended to use fluid in a clean and filtered condition only. Atomizing air should also be clean and led to the guns or spray valves following their individual manuals.

5.1 Cleaning

To clean pressure tank, spray solvent until pure solvent leaves nozzles of either spray gun or spray valve. Do not submerge the entire unit in solvent. If necessary use a soft brush.

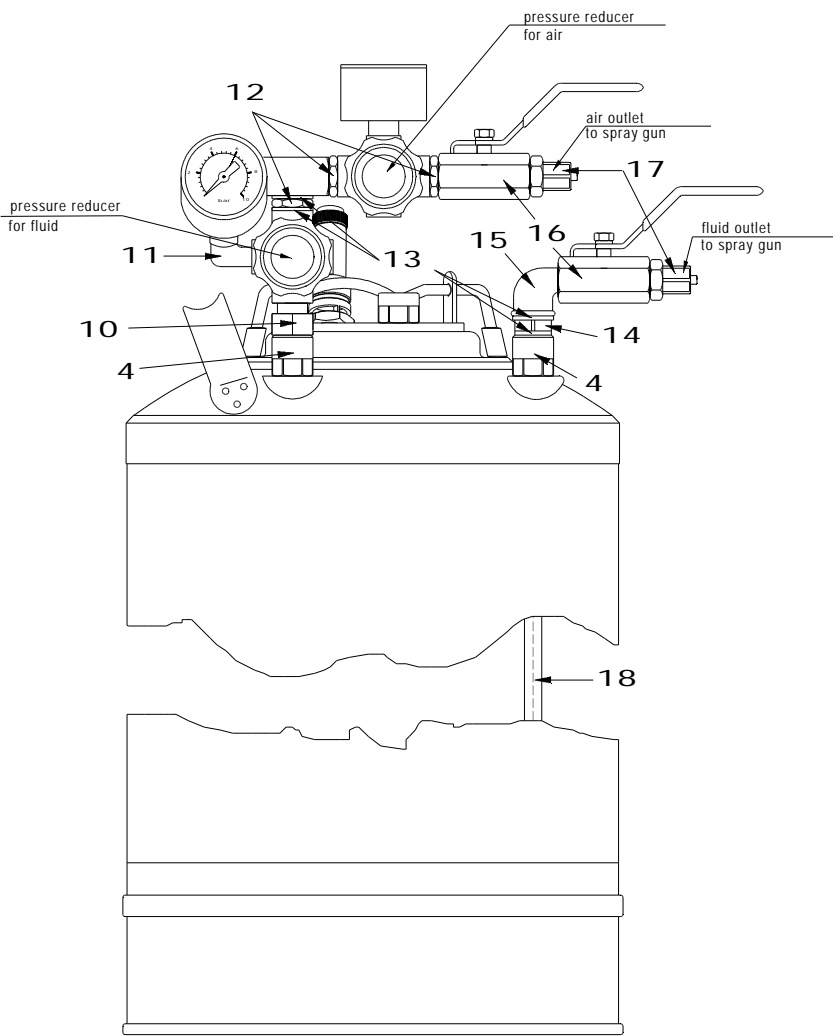
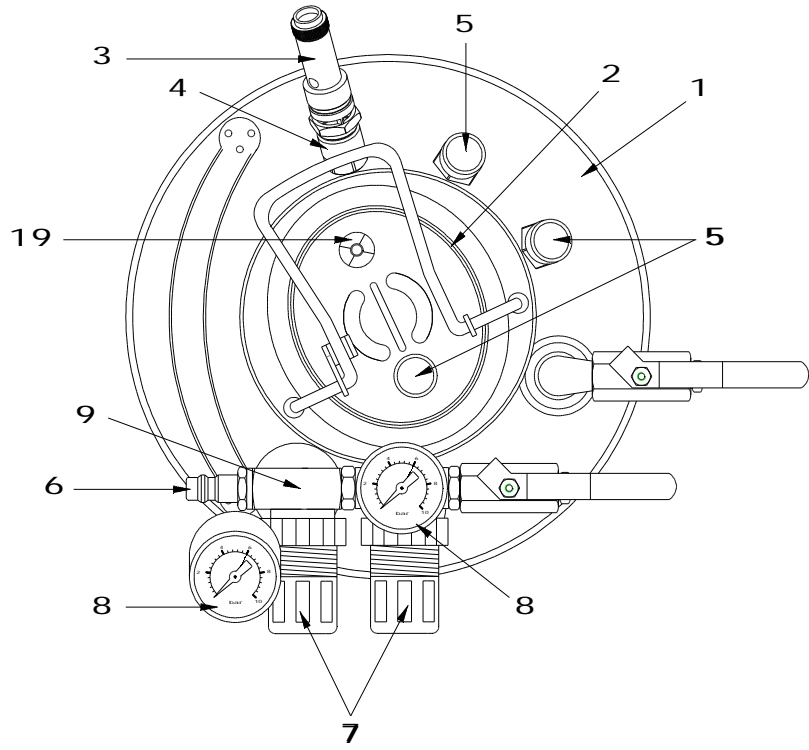

6. Sparepartslist

draw no.	part no.	Qty.	Description
1	*	1	tank
2	640321	1	o-ring
3	630002	1	safety valve 1/4", type approved
4	220421	3	connection, Drm. 19 x 19mm, SW 17
5	220420	3	closing cap, Drm. 19 x 14mm, SW 17
6	220024	1	connection nipple for quick coupler
7	800003	2	pressure reducer 0-7,5 bar
8	450001	2	gauge 0-10 bar
9	220012	1	T-fitting 1/4"
10	220143	1	double nipple 1/4", brass
11	220059	1	connection 90° 1/8" IG/AG / brass
12	220035	3	double nipple 1/4", brass
13	640082	8	plastic washer 1/4"
14	220180	1	double nipple 1/4", stainless steel
15	220218	1	connection 90° 1/4" IG/AG / stainless steel
16	380015	2	cock, 1/4" IG / stainless steel
17	*	2	air and fluid outlet
18	*	1	standpipe
19	XXXXXX	1	quick air-release valve (no sparepart)

* tank

draw no.	part no.	Description
1	350153	tank 9 litre
1	350155	tank 18 litres

* air and fluid outlet

draw no.	part no.	Description
17	220023	for hose 6/4 (standard version)
17	220298	for hose 8/6

* standpipe

draw no.	part no.	Description
18	850366	standpipe for 9 litres tank
18	850367	standpipe for 18 litres tank

7. Technical Data

volume : DG 9 = 9litre
 : DG 18 = 18litres
max. pressure : 6 bar
material of tank : Stainless Steel
high of tank (with armatures) : DG 9 = approx. 450mm
 : DG 18 = approx. 660mm
diameter : both tanks approx. 124mm
max. temperature : 50° C
min. temperature : 5° C

Special designs on request. Technical alterations reserved. March 2002

The material pressure tank **DG 9** resp. **DG 18** was constructed and produced by **ALFRED SCHÜTZE Apparatebau GmbH, Hannoversche Straße 69-71, 28309 Bremen-Germany**. These pressure tanks do not to be subject to

Place	Date	Signature of Manufacturer
Bremen	04.03.2002	