

Agitators

Air operated agitators

Product families

Agitators A MAN – manual air operated agitators

Agitators A FIX – fix mounted air operated agitators



Agitators A MAN

Manual air operated agitators

Dürr has developed a group of pneumatic agitators used in the preparation of paint before application or to prevent settling of the paint during spraying. Various shaft lengths are available. An optional stand is available to allow mixing without assistance of the operator. The pneumatic drive allows the safe use in a paint shop environment.



PRODUCT LINE					
	AGITATOR A MAN R PR 75 330 SE2	AGITATOR A MAN R PR 75 369 SE2	AGITATOR A MAN R PR 75 440 SE2	AGITATOR A MAN R PR 75 550 SE2	AGITATOR A MAN R PR 75 650 SE2
Part No.	N68040616	N68040617	N68040618	N68040619	N68040620
Shaft length	330 mm	369 mm	440 mm	550 mm	650 mm
Propeller diameter	75 mm	75 mm	75 mm	75 mm	75 mm
Geometry blades	Propeller	Propeller	Propeller	Propeller	Propeller
Rated power	0.07 kW	0.07 kW	0.07 kW	0.07 kW	0.07 kW
Recom. air pressure	0.5-7.0 bar (7-101 psi)	0.5-7.0 bar (7-101 psi)	0.5-7.0 bar (7-101 psi)	0.5-7.0 bar (7-101 psi)	0.5-7.0 bar (7-101 psi)
Max. rotation speed	800 rpm	800 rpm	800 rpm	800 rpm	800 rpm



	AGITATOR A MAN R PR 100 330 SE2	AGITATOR A MAN R PR 100 440 SE2	AGITATOR A MAN R PR 100 550 SE2	AGITATOR A MAN R PR 100 650 SE2
Part No.	N68040621	N68040622	N68040623	N68040624
Shaft length	330 mm	440 mm	550 mm	650 mm
Propeller diameter	100 mm	100 mm	100 mm	100 mm
Geometry blades	Propeller	Propeller	Propeller	Propeller
Rated power	0.07 kW	0.07 kW	0.07 kW	0.07 kW
Recom. air pressure	0.5-7.0 bar (7-101 psi)	0.5-7.0 bar (7-101 psi)	0.5-7.0 bar (7-101 psi)	0.5-7.0 bar (7-101 psi)
Max. rotation speed	800 rpm	800 rpm	800 rpm	800 rpm

Agitators A MAN

Manual air operated agitators

TECHNICAL ILLUSTRATION

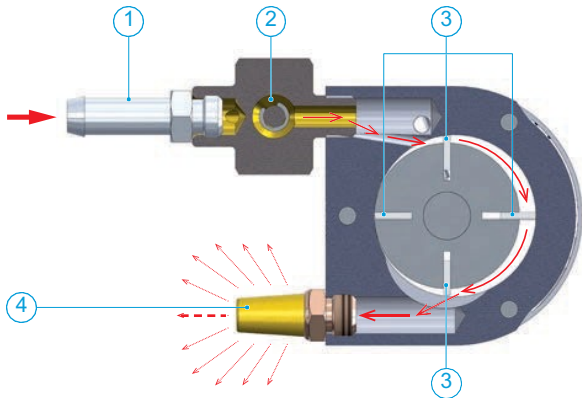

Pneumatic motor

1 Air inlet, 2 Air regulator, 3 Vane, 4 Rotor, 5 Silencer

CUSTOMER BENEFITS



Suitable for paint shops

Manual speed regulation

Optional stand

Stainless steel shaft and propeller

Wide range of shaft lengths available

Easy operation & maintenance

ATEX mark Ex II 2G Ex h IIC T6 GbX



ACCESSORIES

	Stand 330	Stand 440-650
Part No.	N25220010	N25220011
Agitator type	Agitator A MAN	Agitator A MAN
Agitator length	330 mm	440-650 mm
Usage	Agitator support while mixing material in the pot. Made of stainless steel.	Agitator support while mixing material in the pot. Made of stainless steel.

Agitators A FIX

Fix mounted air operated agitators

Good preparation is essential for high quality application of the material (paint, glue, penetration etc.). For large containers, Dürr has developed a line of fixed mounted agitators. They are available for 60 or 200 liter (15 or 60 gallon) tanks. The agitators are air operated and usually fixed to the lid of the container. There are multiple propellers available selected by the material used.



PRODUCT LINE				
	Agitator A FIXR PR 185 580 NON-EX	Agitator A FIXR PR 185 860 NON-EX	Agitator A FIXR PR 185 395	Agitator A FIXR PR 185 545
Part No.	N68040611	N68040612	N68040455	N68040456
Shaft length	580 mm	860 mm	395 mm	545 mm
Propeller diameter	185 mm	185 mm	185 mm	185 mm
No. of propellers	1	2	1	1
Barrel volume	60 liters (15 gallons)	200 liters (52 gallons)	45L (in Pressure Pot)	60L (in Pressure Pot)
Rated power	0.7 kW	0.7 kW	0.7 kW	0.7 kW
Air pressure, range	0.5-7.0 bar (7-101 psi)	0.5-7.0 bar (7-101 psi)	0.5-6.0 bar (7-87psi)	0.5-6.0 bar (7-87psi)
Max. rotation speed	1,000 rpm	1,000 rpm	1200 rpm	1200 rpm
ATEX	No Ex	No Ex	zone 0/1	zone 0/1

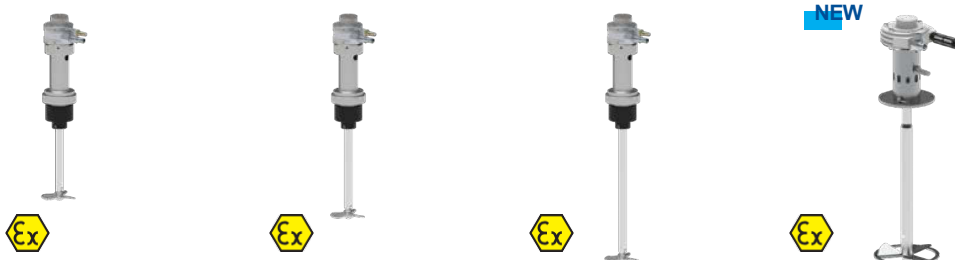

	Agitator A FIXR PR 75 370	Agitator A FIXR PR 75 275	Agitator A FIXR PR 75 370	Agitator A FIXR PR 75-210 100-770-G CORE
Part No.	N68040452	N68040453	N68040454	see table on page 110
Shaft length	205 mm	275 mm	370 mm	100-770 mm
Propeller diameter	75 mm	75 mm	75 mm	75-210 mm
No. of propellers	1	1	1	1
Barrel volume	10L (in Pressure Pot)	12/20L (in Pressure Pot)	22L (in Pressure Pot)	—
Rated power	0,07 kW	0,07 kW	0,07 kW	0,63 kW
Air pressure, range	0.5-6.0 bar (7-87psi)	0.5-6.0 bar (7-87psi)	0.5-6.0 bar (7-87psi)	0.5-6.0 bar (7-87psi)
Max. rotation speed	1200 rpm	1200 rpm	1200 rpm	1200 rpm
ATEX	zone 0/1	zone 0/1	zone 0/1	zone 0/1

* Available in Q1 2023

Agitators A FIX

Fix mounted air operated agitators

TECHNICAL ILLUSTRATION

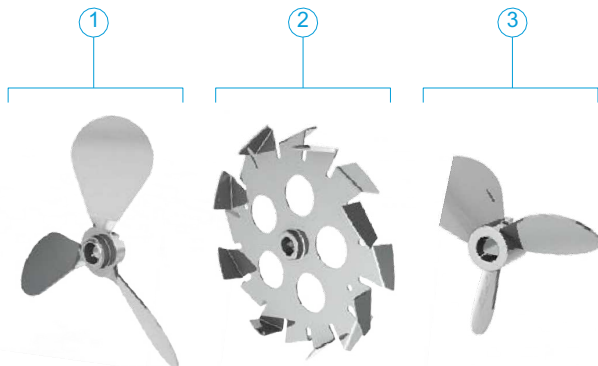

1 Propeller D185 mm, 2 Propeller type TD127 mm, 3 Disc Paddle D180 mm
Note: Propellers are compatible only with Agitator A FIX (N68040611, N68040612)

CUSTOMER BENEFITS



- Propeller made of stainless steel
- Usable in explosive hazardous environment
- Multiple propeller sizes and types
- Air inlet regulator for speed control

ORDER NUMBERS FOR AGITATOR A FIX R PR 75-210 100-770-G CORE



Propeller diameter & part number

Ø 75mm	Ø 100mm	Ø 140mm	Ø 185mm	Ø 210mm
M04640018	M04640017	M04640016	M04640022	M04640015

Shaft length (mm)	Shaft part number	Agitator part numbers				
		Ø 75mm	Ø 100mm	Ø 140mm	Ø 185mm	Ø 210mm
100	M04081071	N68040685	N68040700	N68040715	N68040730	N68040745
120	M04081072	N68040686	N68040701	N68040716	N68040731	N68040746
170	M04081073	N68040687	N68040702	N68040717	N68040732	N68040747
220	M04081074	N68040688	N68040703	N68040718	N68040733	N68040748
270	M04081075	N68040689	N68040704	N68040719	N68040734	N68040749
320	M04081076	N68040690	N68040705	N68040720	N68040735	N68040750
370	M04081077	N68040691	N68040706	N68040721	N68040736	N68040751
420	M04081078	N68040692	N68040707	N68040722	N68040737	N68040752
470	M04081079	N68040693	N68040708	N68040723	N68040738	N68040753
520	M04081080	N68040694	N68040709	N68040724	N68040739	N68040754
570	M04081081	N68040695	N68040710	N68040725	N68040740	N68040755
620	M04081082	N68040696	N68040711	N68040726	N68040741	N68040756
670	M04081083	N68040697	N68040712	N68040727	N68040742	N68040757
720	M04081084	N68040698	N68040713	N68040728	N68040743	N68040758
770	M04081085	N68040699	N68040714	N68040729	N68040744	N68040759