

# Low Flow Fluid Regulator

3A0427A

ENG

**Pneumatic controlled fluid regulator provides accurate, positive pressure control of finishing coatings in low flow applications. For professional use only.**

*100 psi (0.7 MPa, 7 bar) Maximum Air Inlet Pressure*

*300 psi (2.1 MPa, 21 bar) Maximum Fluid Inlet Pressure*

*90 psi (0.63 MPa, 6.3 bar) Maximum Regulated Fluid Pressure (High Pressure Port, All Models)*

## **Part No. 24C375, Series A**

1:1 Ratio, 90 psi (0.63 MPa, 6.3 bar) Maximum Regulated Fluid Pressure (Low Pressure Port)

## **Part No. 24E471, Series A**

1:2 Ratio, 50 psi (0.35 MPa, 3.5 bar) Maximum Regulated Fluid Pressure (Low Pressure Port)

## **Part No. 24E472, Series A**

1:3 Ratio, 30 psi (0.21 MPa, 2.1 bar) Maximum Regulated Fluid Pressure (Low Pressure Port)



### **Important Safety Instructions**

Read all warnings and instructions in this manual. Save these instructions.

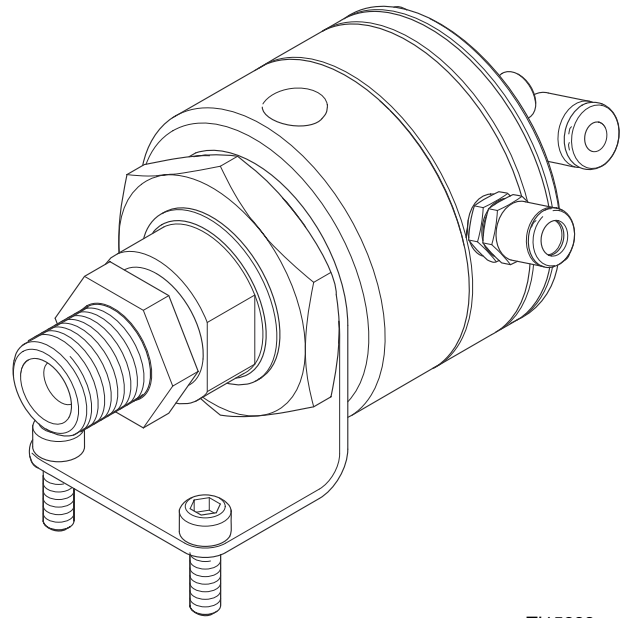



T115288a

# Contents

<b>Warnings</b> .....	<b>2</b>	<b>Troubleshooting</b> .....	<b>8</b>
<b>Installation</b> .....	<b>4</b>	<b>Repair</b> .....	<b>10</b>
Mount the Fluid Regulator .....	4	Disassembly .....	10
Grounding .....	4	Reassembly .....	10
Air Supply .....	4	Change the Ratio .....	10
Fluid Inlet Line .....	4	<b>Parts</b> .....	<b>12</b>
Regulated Fluid Outlet Line .....	4	<b>Dimensions</b> .....	<b>14</b>
Flush Before Using Equipment .....	4	<b>Technical Data</b> .....	<b>15</b>
<b>Operation</b> .....	<b>7</b>	<b>Performance Data</b> .....	<b>16</b>
Pressure Relief Procedure .....	7	<b>Graco Standard Warranty</b> .....	<b>18</b>
Available Pressures .....	7		
High Port Operation .....	7		
Low Port Operation .....	7		
Adjust the Fluid Regulator .....	7		
Flushing .....	7		

# Warnings

The following warnings are for the setup, use, grounding, maintenance, and repair of this equipment. The exclamation point symbol alerts you to a general warning and the hazard symbols refer to procedure-specific risks. When these symbols appear in the body of this manual, refer back to these Warnings. Product-specific hazard symbols and warnings not covered in this section may appear throughout the body of this manual where applicable.

 <span style="font-size: 2em; font-weight: bold; margin-left: 10px;">WARNING</span>	
	<p><b>FIRE AND EXPLOSION HAZARD</b></p> <p>Flammable fumes, such as solvent and paint fumes, in <b>work area</b> can ignite or explode. To help prevent fire and explosion:</p> <ul style="list-style-type: none"> <li>• Use equipment only in well ventilated area.</li> <li>• Eliminate all ignition sources; such as pilot lights, cigarettes, portable electric lamps, and plastic drop cloths (potential static arc).</li> <li>• Keep work area free of debris, including solvent, rags and gasoline.</li> <li>• Do not plug or unplug power cords, or turn power or light switches on or off when flammable fumes are present.</li> <li>• Ground all equipment in the work area. See <b>Grounding</b> instructions.</li> <li>• Use only grounded hoses.</li> <li>• Hold gun firmly to side of grounded pail when triggering into pail.</li> <li>• If there is static sparking or you feel a shock, <b>stop operation immediately</b>. Do not use equipment until you identify and correct the problem.</li> <li>• Keep a working fire extinguisher in the work area.</li> </ul>

# ! WARNING



## PRESSURIZED EQUIPMENT HAZARD

Fluid from the gun/dispense valve, leaks, or ruptured components can splash in the eyes or on skin and cause serious injury.

- Follow the **Pressure Relief Procedure** when you stop spraying and before cleaning, checking, or servicing equipment.
- Tighten all fluid connections before operating the equipment.
- Check hoses, tubes, and couplings daily. Replace worn or damaged parts immediately.



## EQUIPMENT MISUSE HAZARD

Misuse can cause death or serious injury.



- Do not operate the unit when fatigued or under the influence of drugs or alcohol.
- Do not exceed the maximum working pressure or temperature rating of the lowest rated system component. See **Technical Data** in all equipment manuals.
- Use fluids and solvents that are compatible with equipment wetted parts. See **Technical Data** in all equipment manuals. Read fluid and solvent manufacturer's warnings. For complete information about your material, request MSDS from distributor or retailer.
- Do not leave the work area while equipment is energized or under pressure. Turn off all equipment and follow the **Pressure Relief Procedure** when equipment is not in use.
- Check equipment daily. Repair or replace worn or damaged parts immediately with genuine manufacturer's replacement parts only.
- Do not alter or modify equipment.
- Use equipment only for its intended purpose. Call your distributor for information.
- Route hoses and cables away from traffic areas, sharp edges, moving parts, and hot surfaces.
- Do not kink or over bend hoses or use hoses to pull equipment.
- Keep children and animals away from work area.
- Comply with all applicable safety regulations.



## TOXIC FLUID OR FUMES HAZARD

Toxic fluids or fumes can cause serious injury or death if splashed in the eyes or on skin, inhaled, or swallowed.



- Read MSDSs to know the specific hazards of the fluids you are using.
- Store hazardous fluid in approved containers, and dispose of it according to applicable guidelines.



## PERSONAL PROTECTIVE EQUIPMENT

You must wear appropriate protective equipment when operating, servicing, or when in the operating area of the equipment to help protect you from serious injury, including eye injury, hearing loss, inhalation of toxic fumes, and burns. This equipment includes but is not limited to:

- Protective eyewear, and hearing protection.
- Respirators, protective clothing, and gloves as recommended by the fluid and solvent manufacturer.

# Installation

## Mount the Fluid Regulator

See FIG. 1. Mount the fluid regulator (C) in a location close to the fluid dispense device. A mounting bracket (D) is supplied. See **Dimensions** on page 14 for mounting information.

## Grounding

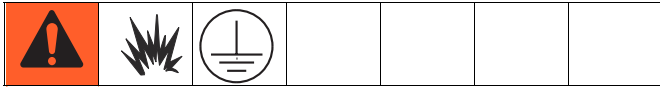

The equipment must be grounded. Mount the regulator to a conductive mounting surface (E) which is connected to a true earth ground. Follow local code. Graco Part No. 222011 Ground Wire and Clamp is available as an accessory. See FIG. 1.

## Air Supply

The regulator's air inlet fittings accept 5/32 in. (4 mm) OD tubing. Air pressure can be controlled manually or with electronic pressure controls.

Connections can be made in two ways:

- Use separate high (A) and low (B) air pressure supply lines, connected as shown in FIG. 1.
- Use a single air supply line and connect it to the high or low pressure air inlet fitting alternately, as desired.

## Fluid Inlet Line

See FIG. 1. Connect the fluid inlet line (G) between the 1/4 npt(m) fluid inlet fitting and the fluid supply.

Install the following accessories in the order shown in FIG. 1, using adapters as necessary.

- **Fluid filter (H):** to filter particles from the fluid before it passes through the fluid regulator.
- **Fluid drain valve (J):** required in your system, to relieve fluid pressure in the fluid regulator.
- **Fluid shutoff valve (K):** shuts off fluid flow.

## Regulated Fluid Outlet Line

See FIG. 1. Connect the regulated fluid outlet line (F) between the 1/8 npt(f) fluid outlet port and the system's fluid dispense point.

**NOTE:** All components located downstream of the fluid regulator must be rated for the maximum fluid inlet pressure sent to the regulator. Do not use the regulator as a fluid shutoff valve.

## Flush Before Using Equipment

The equipment was tested with a rust inhibiting test fluid. To avoid contaminating your system, flush the equipment with a compatible solvent before using the equipment. See **Flushing**, page 7.

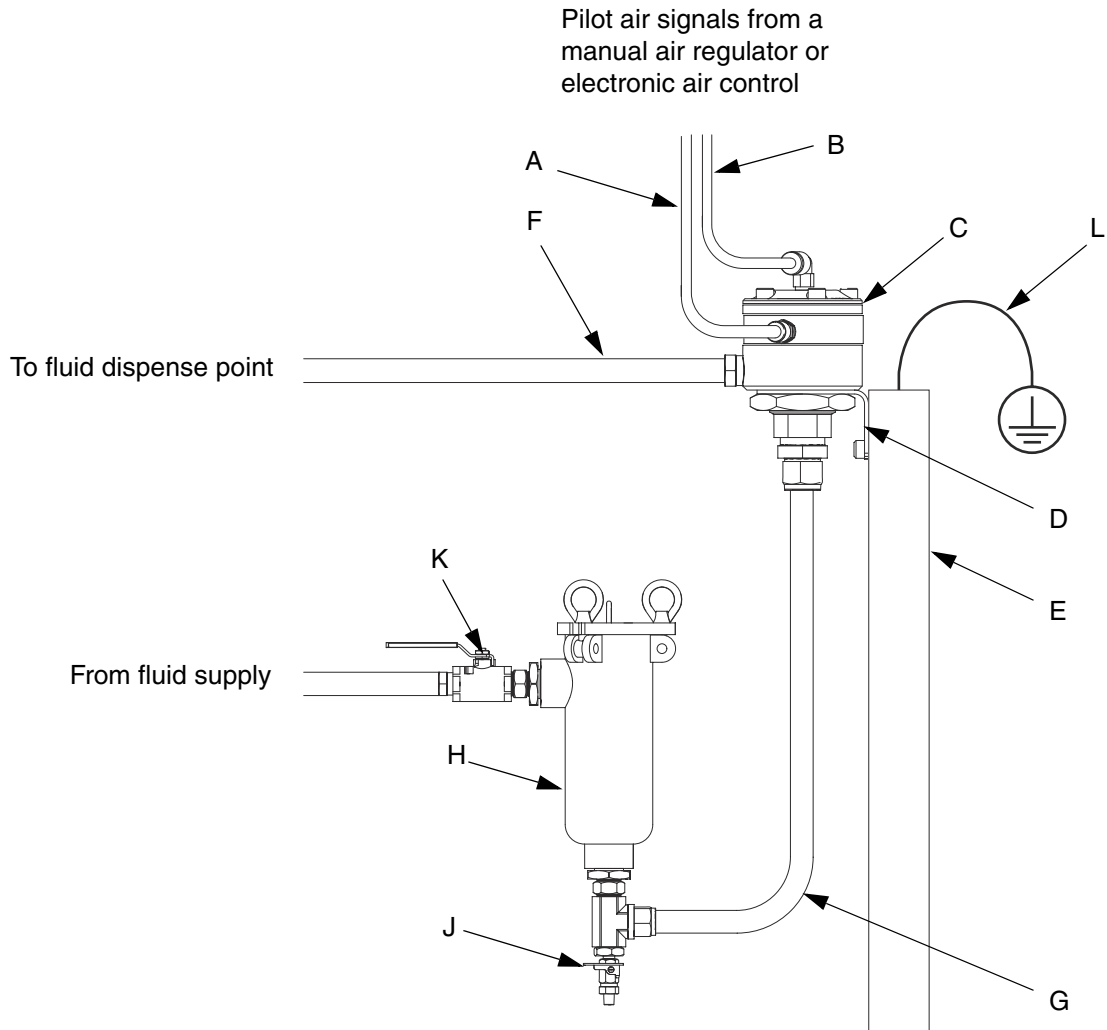

T115498a

**FIG. 1: Typical Installation**

- Key:**
- A Air Supply Line to High Port
  - B Air Supply Line to Low Port
  - C Low Flow Fluid Regulator
  - D Mounting Bracket (supplied)
  - E Grounded Mounting Surface
  - F Regulated Fluid Outlet Line
  - G Fluid Inlet Supply Line
  - H Fluid Filter
  - J Fluid Drain Valve (required)
  - K Fluid Shutoff Valve
  - L Ground Wire and Clamp (Part No. 222011)



# Operation

## Pressure Relief Procedure



1. Shut off the fluid supply.
2. Leave on the air to the fluid regulator.
3. Trigger the gun to relieve the fluid pressure.
4. Shut off the air supply to the fluid regulator.
5. Open the fluid drain valve to relieve all fluid pressure, having a container ready to catch the drainage.

## Available Pressures

This fluid regulator provides accurate, positive fluid pressure control to a spray gun or other device. The regulated fluid outlet pressure is proportional to the pilot air signal supplied to either the high or low air inlet port. Each port can be controlled independently.

All three models have the high pressure port, which is fixed at 1:1. Ratios of 1:1, 1:2, and 1:3 are available for low pressure applications. The ratio spacer (3, FIG. 2) is color coded to indicate ratio:

- Silver (1:1 ratio)
- Green (1:2 ratio)
- Black (1:3 ratio)

See the **Performance Data** on pages 16 and 17 to help determine which ratio is best for your application. Performance is affected by:

- Fluid inlet pressure
- Fluid viscosity
- Size (ID) and length of the regulated fluid outlet line
- Size (ID) and length of the fluid inlet supply line.

## High Port Operation

Use the high port for:

- commanding a higher pressure for faster flushing
- higher fluid viscosities

To operate, shut off the air to the low pressure inlet and turn on the air to the high pressure inlet.

## Low Port Operation

Use the low port for:

- precise control in critical applications
- lower fluid viscosities

To operate, shut off the air to the high pressure inlet and turn on the air to the low pressure inlet.

## Adjust the Fluid Regulator

The fluid regulator controls pressure downstream from its outlet. Set the inlet fluid pressure at least 10 psi (.07 MPa, 0.7 bar) higher than the regulated outlet fluid pressure.

Apply a pilot air signal to either the high or low port. The minimum air pressure depends on the ratio. See the **Performance Data** on pages 16 and 17.

If using an accessory fluid pressure gauge, trigger the air spray gun to relieve pressure in the line when reducing the pressure, to ensure a correct gauge reading.

## Flushing

- Flush before changing colors, at the end of the day, before storing, and before repairing the equipment.
- Flush with a fluid that is compatible with the fluid you are pumping and with the wetted parts of your system. Check with your fluid manufacturer or supplier for recommended flushing fluids and flushing frequency. Relieve the pressure after flushing.
- Do not allow paint or solvent to sit in the system for extended periods.

# Troubleshooting

Relieve the pressure (page 7) before checking or repairing the equipment.

To repair the regulator, refer to page 10.

Problem	Cause	Solution
No fluid flow.	Plugged fluid inlet.	Flush fluid line and regulator.
	Exhausted fluid supply.	Check fluid supply and supply pump.
	No air inlet pressure.	Check air inlet pressure.
	Ruptured air diaphragm (15).	Replace. See page 10.
	Ruptured fluid diaphragms (9a, 9b).	Replace. See page 10.
Low fluid flow.	Incorrect ratio.	Use correct spacer (3) and ratio piston (14) for desired ratio. See <b>Change the Ratio</b> , page 10.
	Fluid supply pressure is too low.	Increase fluid pressure. Do not exceed 300 psi (2.1 MPa, 21 bar).
	Air inlet pressure is too low.	Increase air inlet pressure.
High fluid flow.	Incorrect ratio.	Use correct spacer (3) and ratio piston (14) for desired ratio. See <b>Change the Ratio</b> , page 10.
	Air inlet pressure is too high.	Decrease air inlet pressure.
Erratic fluid flow.	Damaged fluid diaphragms (9a, 9b).	Replace. See page 10.
	Ruptured air diaphragm (15).	Replace. See page 10.
	Ruptured fluid diaphragms (9a, 9b).	Replace. See page 10.
	Inconsistent air inlet pressure.	Check air inlet pressure.
	Inconsistent fluid inlet pressure.	Check fluid inlet pressure.



Problem	Cause	Solution
Fluid flow will not shut off.	Dirty needle (6) and seat (5).	Remove and clean. Replace if worn or damaged. See page 10.
	Inlet air is not shut off.	Shut off inlet air.
	Seat retainer (7) is loose.	Tighten.
	Broken spring (13).	Replace spring (13). See page 10.
Regulator is leaking fluid.	Screws (17) are loose.	Torque oppositely and alternately to 25 in-lb (2.8 N•m).
	Ruptured fluid diaphragms (9a, 9b).	Replace. See page 10.
	Loose fluid fitting.	Tighten.
Regulator is leaking air.	Loose air fitting.	Tighten.
	Screws (17) are loose.	Torque oppositely and alternately to 25 in-lb (2.8 N•m).
	Ruptured air diaphragm (15).	Replace. See page 10.

# Repair

## Disassembly

1. Flush the regulator with a compatible solvent. See page 7.
2. Relieve pressure. See page 7.
3. Disconnect the air and fluid lines from the regulator. Remove the regulator for repair.
4. Remove the fluid inlet fitting (20). See FIG. 2.
5. Remove five screws (17), the air chamber cover (4), air diaphragm (15), spacer (3), and gasket (29).
6. Unscrew the ratio piston (14). Remove the spring (13) and air chamber housing (2).
7. Insert a standard screwdriver into the fluid inlet of the regulator and hold the regulator needle (6) steady. Unscrew the air chamber piston (10).
8. Remove the fluid diaphragms (9a, 9b), o-ring (11), and fluid chamber piston (8). Push the needle (6) out of the fluid chamber housing (1) inlet port.
9. Using a 5/16 allen wrench, unscrew the seat retainer (7) and seat (5) from the fluid chamber housing (1).
10. Clean all parts and inspect for damage.

## Reassembly

**NOTE:** Rebuild Kit 24E504 is available. See page 12 to order. Kit parts are marked with an asterisk, for example 9a\*. For the best results use all parts in the kit.

**NOTE:** Seat Repair Kit 24F140 is available. See page 12 to order. Kit parts are marked with a symbol, for example 7♦. For the best results use all parts in the kit.

1. Using a 5/16 allen wrench, screw the seat retainer (7♦) and seat (5♦) into the fluid chamber housing (1).

**NOTE:** The white ptfе diaphragm (9a\*) must always face the fluid. Install the white ptfе diaphragm first, followed by the black nylon/buna-N diaphragm (9b\*).

2. Insert the needle (6♦) in the fluid chamber housing (1). Hold in place with a screwdriver or allen wrench. Install the fluid chamber piston (8), o-ring (11\*), ptfе diaphragm (9a\*), and nylon/buna-N diaphragm (9b\*).
3. Apply thread sealant to the threads of the needle (6). Screw the air chamber piston (10) onto the needle. Align the holes in the diaphragms before tightening. Tighten using a screwdriver in the slot of the needle.
4. Install the air chamber housing (2). Align the holes in the housing with the holes in the diaphragms (9a, 9b) and fluid chamber housing (1).
5. Install the spring (13). Screw the ratio piston (14) into the air chamber piston (10).
6. Install the gasket (29\*), spacer (3), air diaphragm (15\*), and air chamber cover (4). Align the holes. Install five screws (17). Torque oppositely and alternately to 25 in-lb (2.8 N•m).
7. Apply pipe sealant and install the fluid inlet fitting (20).
8. Reinstall the fluid regulator in the system.

## Change the Ratio

Ratio Kits 24E501, 24E502, and 24E503 are available to change the ratio. See page 12 to order. Kit parts are marked with a symbol, for example 3†. The kits include a spacer (3†) and piston (14†). The ratio spacer is color coded to indicate ratio:

- Silver (1:1 Ratio Kit 24E501)
- Green (1:2 Ratio Kit 24E502)
- Black (1:3 Ratio Kit 24E503)

To install the kit, disassemble the regulator (see page 10). Replace the existing spacer (3) and ratio piston (14) with the desired size, and reassemble. Do not mix spacers and pistons of different sizes.



# Parts

## 24C375 1:1 Ratio Fluid Regulator, Series A

## 24E471 1:2 Ratio Fluid Regulator, Series A

## 24E472 1:3 Ratio Fluid Regulator, Series A

Ref. No.	Part No.	Description	Qty.	Ref. No.	Part No.	Description	Qty.
1	n/a	HOUSING, fluid chamber	1	19	n/a	KIT, bracket, regulator; includes items 19a and 19b	1
2	n/a	HOUSING, air chamber	1	19a	n/a	SCREW, cap, socket hd; 8-32 x 1/2 in. (13 mm)	2
3†	n/a	SPACER, ratio, 1:1, silver (24C375 only)	1	19b	n/a	NUT, hex; 1-12 unf-2B	1
	n/a	SPACER, ratio, 1:2, green (24E471 only)	1	20	n/a	FITTING, fluid inlet; 1/4 npt x 3/8 npt; sst	1
	n/a	SPACER, ratio, 1:3, black (24E472 only)	1	26	n/a	ELBOW, tube, air; 10-32(m) x 5/32 in. (4 mm) OD tube	1
4	n/a	COVER, air chamber	1	27	n/a	CONNECTOR, tube, air; 10-32(m) x 5/32 in. (4 mm) OD tube	1
5*◆	n/a	SEAT, regulator	1	29*	n/a	GASKET, cellulose fiber	1
6◆	n/a	NEEDLE, regulator	1				
7◆	n/a	RETAINER, seat	1				
8	16A585	PISTON, fluid chamber	1				
9a*	n/a	DIAPHRAGM, fluid; ptfе (white)	1				
9b*	n/a	DIAPHRAGM, fluid; nylon/buna-N (black)	1				
10	16A586	PISTON, air chamber	1				
11*	n/a	O-RING; perfluoroelastomer	1				
13	16E537	SPRING, compression; sst	1				
14†	n/a	PISTON, ratio, 1:1 (24C375 only)	1				
	n/a	PISTON, ratio, 1:2 (24E471 only)	1				
	n/a	PISTON, ratio, 1:3 (24E472 only)	1				
15*†	n/a	DIAPHRAGM, air; buna-N	1				
17	n/a	SCREW, cap, socket hd; 8-32 x 1 in. (25 mm); sst	5				

\* Parts included in Rebuild Kit 24E504 (purchase separately).

† Parts included in Ratio Kits (purchase separately):  
 24E501, 1:1 Ratio (silver spacer)  
 24E502, 1:2 Ratio (green spacer)  
 24E503, 1:3 Ratio (black spacer)

◆ Parts included in Seat Kit 24F140 (purchase separately).

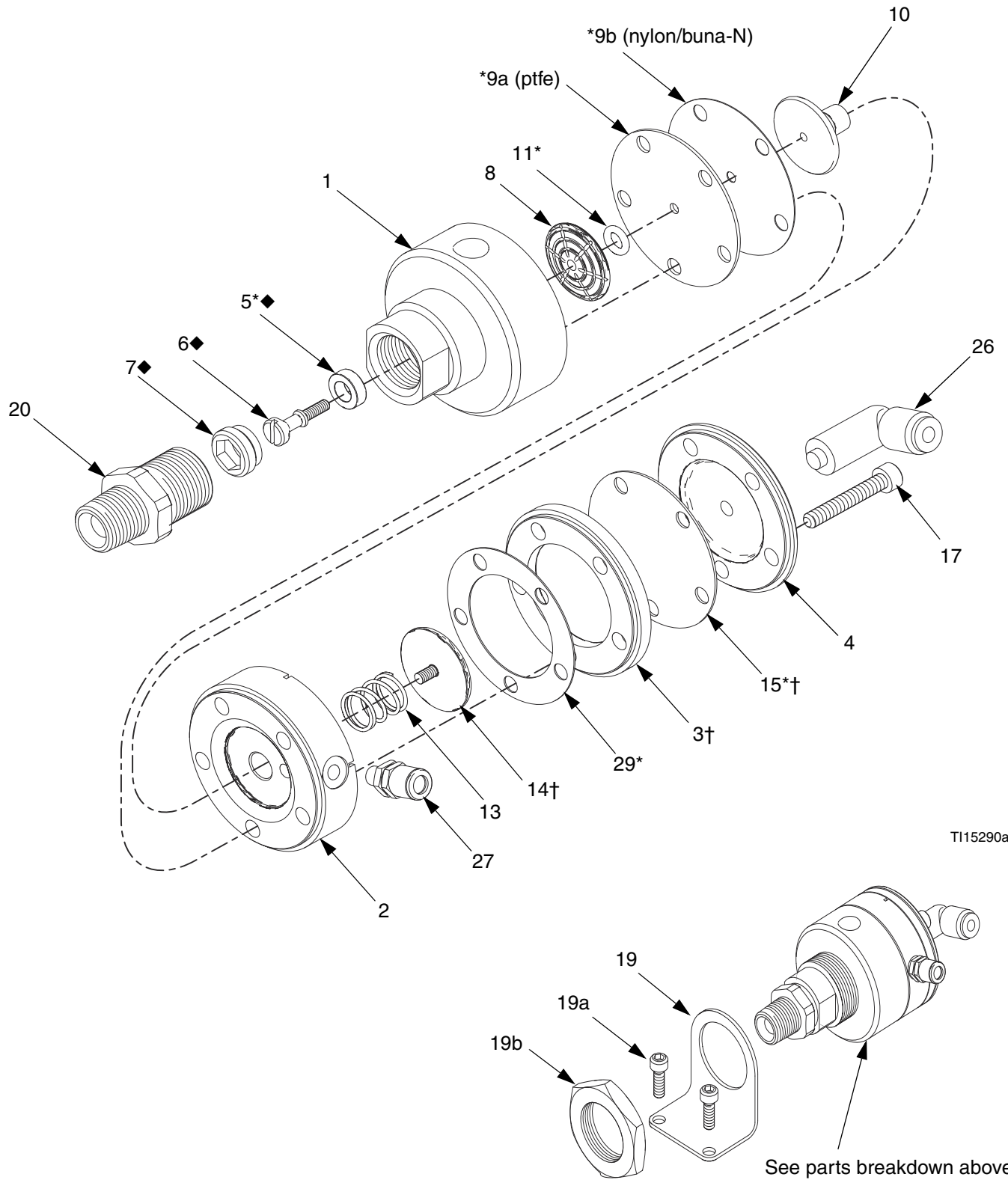

T115290a

T115289a

# Dimensions

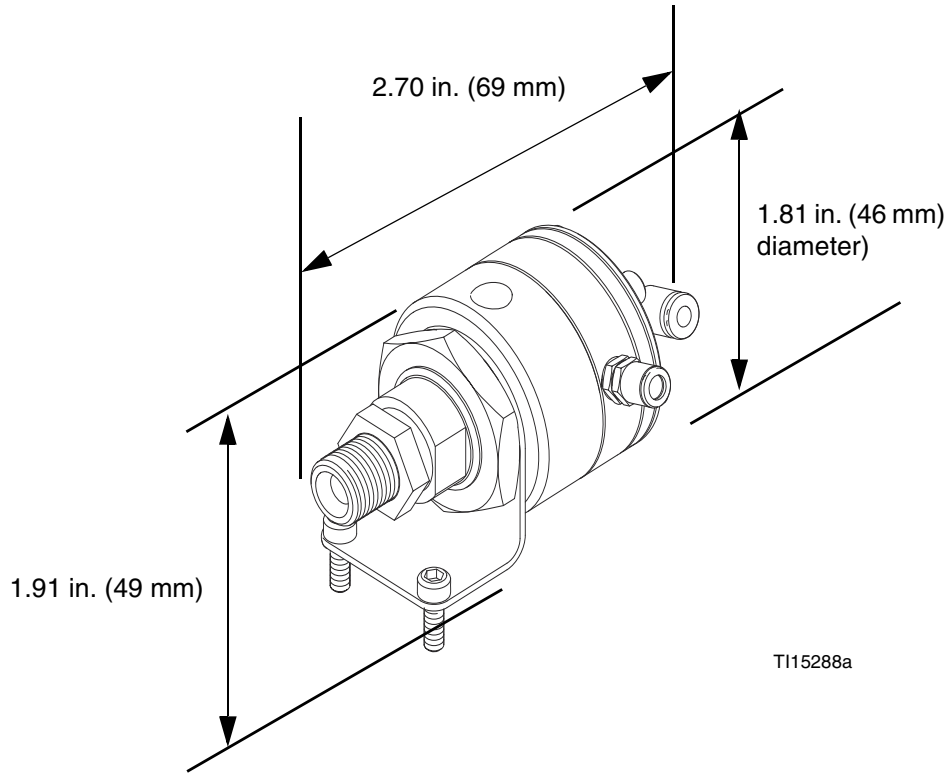

## Bracket Mounting Hole Diagram

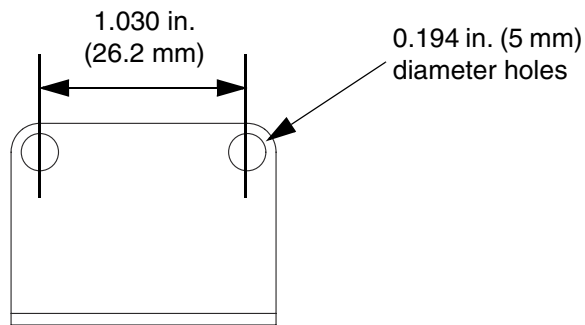

# Technical Data

Maximum air inlet pressure . . . . .	100 psi (0.7 MPa, 7 bar)
Maximum fluid inlet pressure . . . . .	300 psi (2.1 MPa, 21 bar)
Maximum regulated fluid pressure (high pressure port)	All Models . . . . . 90 psi (0.63 MPa, 6.3 bar)
Maximum regulated fluid pressure (low pressure port) .	Model 24C375 . . . . . 90 psi (0.63 MPa, 6.3 bar)
	Model 24E471 . . . . . 50 psi (0.35 MPa, 3.5 bar)
	Model 24E472 . . . . . 30 psi (0.21 MPa, 2.1 bar)
Ratio . . . . .	Model 24C375 . . . . . 1:1
	Model 24E471 . . . . . 1:2
	Model 24E472 . . . . . 1:3
Maximum fluid temperature . . . . .	120°F (49°C)
Wetted parts . . . . .	303 and 17-4 PH grades of stainless steel, ptfe, perfluoroelastomer
Fluid Inlet . . . . .	1/4 npt(m)
Fluid Outlet . . . . .	1/8 npt(f)
Low Pressure Air Inlet . . . . .	5/32 in. (4 mm) OD tube fitting
High Pressure Air Inlet . . . . .	5/32 in. (4 mm) OD tube fitting

# Performance Data

Use the following charts to choose the best ratio for your application, depending on the desired fluid pressure range and pressure losses due to flow rate, fluid viscosity, and fluid line size.

- A higher ratio (1:3) will have a flatter response curve and will not react as strongly to changes in the air pilot signal.
- A lower ratio (1:1) will have a steeper response curve but will cover a wider range of fluid pressure.

The ratio determines the fluid pressure to air pressure response curve:

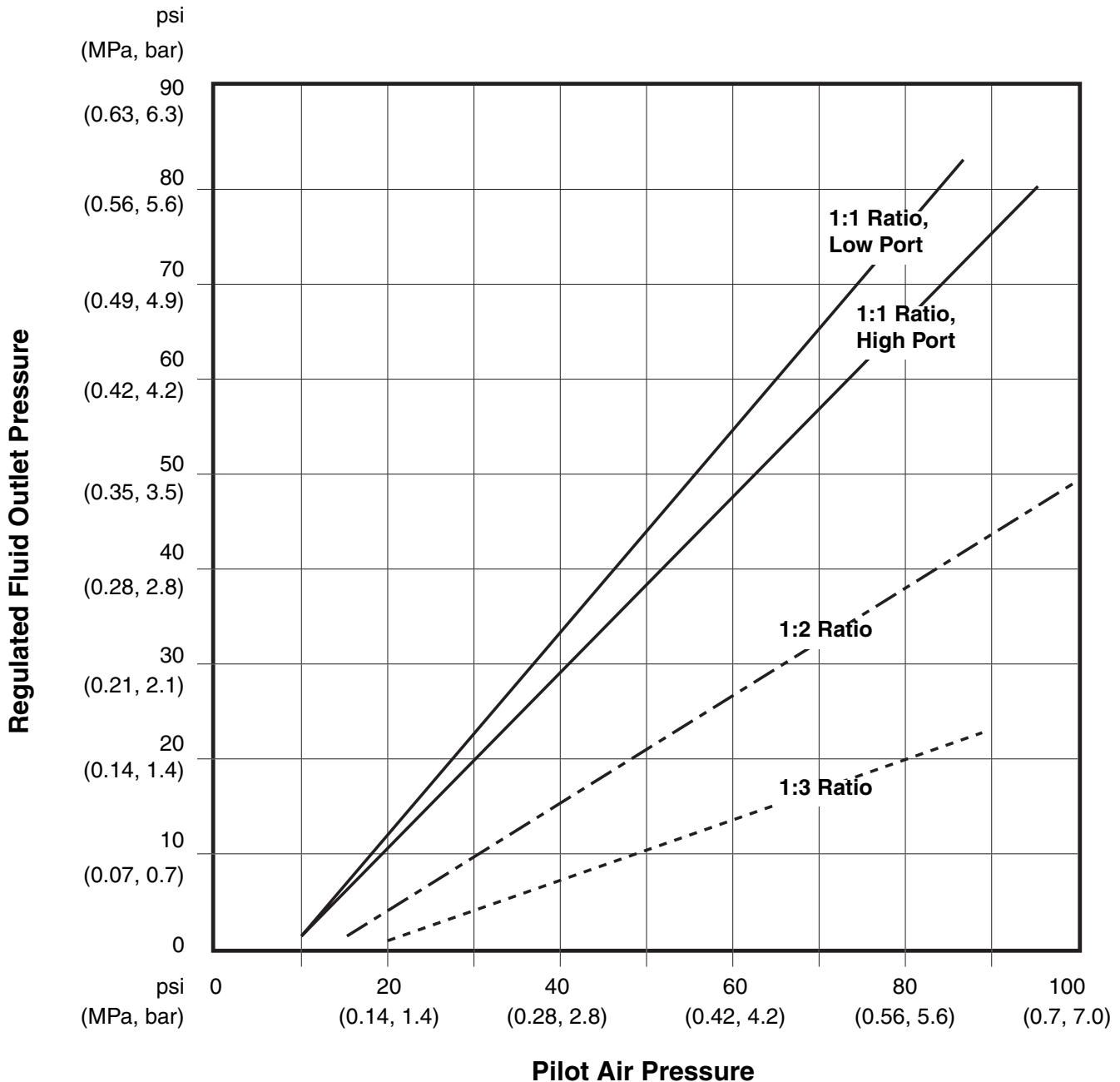



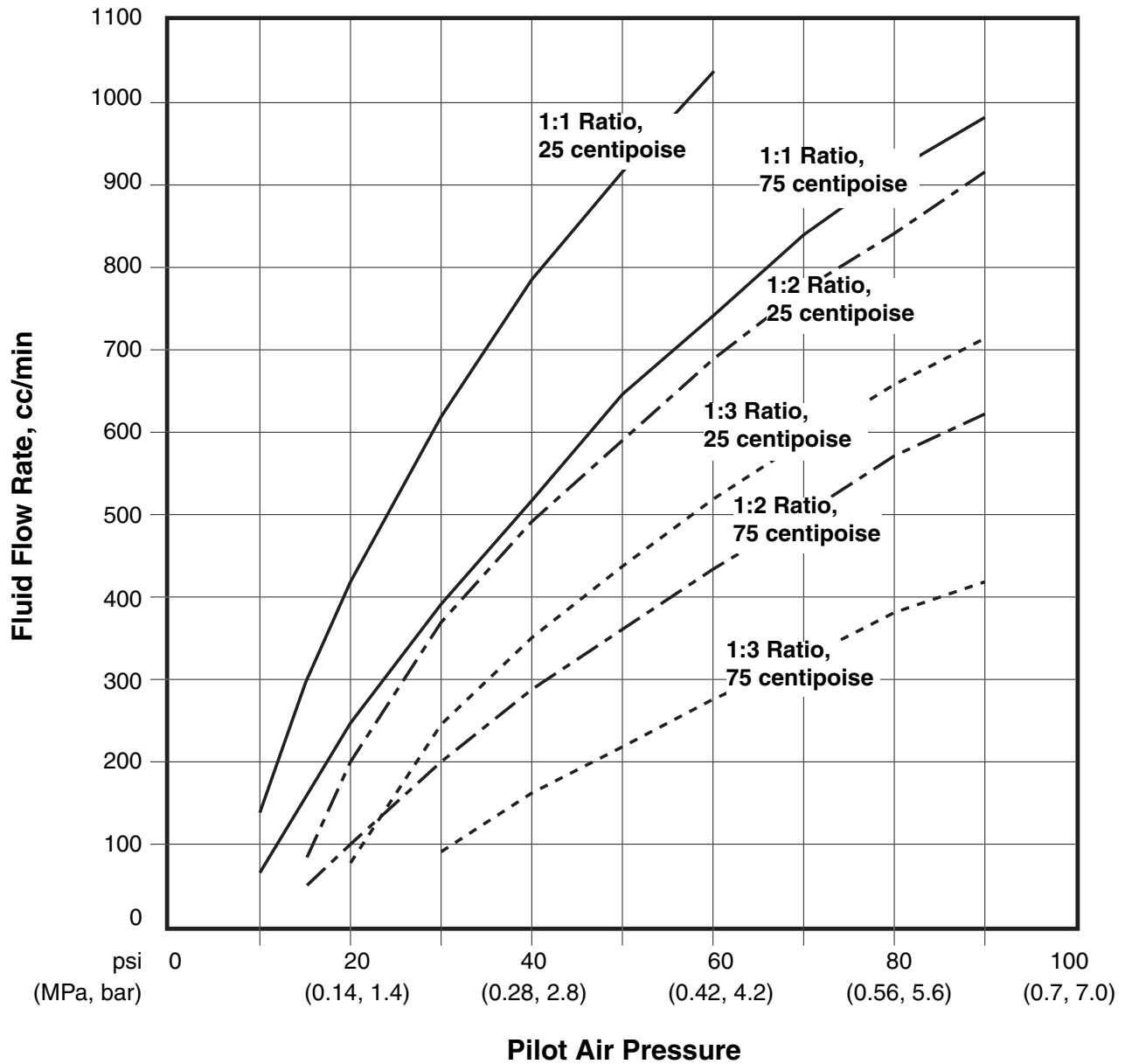

**NOTE:** Tested using a 1.0 mm nozzle and 10 ft x 1/4 in. ID (3.05 m x 6 mm) fluid line.

# Graco Standard Warranty

Graco warrants all equipment referenced in this document which is manufactured by Graco and bearing its name to be free from defects in material and workmanship on the date of sale to the original purchaser for use. With the exception of any special, extended, or limited warranty published by Graco, Graco will, for a period of twelve months from the date of sale, repair or replace any part of the equipment determined by Graco to be defective. This warranty applies only when the equipment is installed, operated and maintained in accordance with Graco's written recommendations.

This warranty does not cover, and Graco shall not be liable for general wear and tear, or any malfunction, damage or wear caused by faulty installation, misapplication, abrasion, corrosion, inadequate or improper maintenance, negligence, accident, tampering, or substitution of non-Graco component parts. Nor shall Graco be liable for malfunction, damage or wear caused by the incompatibility of Graco equipment with structures, accessories, equipment or materials not supplied by Graco, or the improper design, manufacture, installation, operation or maintenance of structures, accessories, equipment or materials not supplied by Graco.

This warranty is conditioned upon the prepaid return of the equipment claimed to be defective to an authorized Graco distributor for verification of the claimed defect. If the claimed defect is verified, Graco will repair or replace free of charge any defective parts. The equipment will be returned to the original purchaser transportation prepaid. If inspection of the equipment does not disclose any defect in material or workmanship, repairs will be made at a reasonable charge, which charges may include the costs of parts, labor, and transportation.

**THIS WARRANTY IS EXCLUSIVE, AND IS IN LIEU OF ANY OTHER WARRANTIES, EXPRESS OR IMPLIED, INCLUDING BUT NOT LIMITED TO WARRANTY OF MERCHANTABILITY OR WARRANTY OF FITNESS FOR A PARTICULAR PURPOSE.**

Graco's sole obligation and buyer's sole remedy for any breach of warranty shall be as set forth above. The buyer agrees that no other remedy (including, but not limited to, incidental or consequential damages for lost profits, lost sales, injury to person or property, or any other incidental or consequential loss) shall be available. Any action for breach of warranty must be brought within two (2) years of the date of sale.

**GRACO MAKES NO WARRANTY, AND DISCLAIMS ALL IMPLIED WARRANTIES OF MERCHANTABILITY AND FITNESS FOR A PARTICULAR PURPOSE, IN CONNECTION WITH ACCESSORIES, EQUIPMENT, MATERIALS OR COMPONENTS SOLD BUT NOT MANUFACTURED BY GRACO.** These items sold, but not manufactured by Graco (such as electric motors, switches, hose, etc.), are subject to the warranty, if any, of their manufacturer. Graco will provide purchaser with reasonable assistance in making any claim for breach of these warranties.

In no event will Graco be liable for indirect, incidental, special or consequential damages resulting from Graco supplying equipment hereunder, or the furnishing, performance, or use of any products or other goods sold hereto, whether due to a breach of contract, breach of warranty, the negligence of Graco, or otherwise.

## **FOR GRACO CANADA CUSTOMERS**

The Parties acknowledge that they have required that the present document, as well as all documents, notices and legal proceedings entered into, given or instituted pursuant hereto or relating directly or indirectly hereto, be drawn up in English. Les parties reconnaissent avoir convenu que la rédaction du présente document sera en Anglais, ainsi que tous documents, avis et procédures judiciaires exécutés, donnés ou intentés, à la suite de ou en rapport, directement ou indirectement, avec les procédures concernées.

# Graco Information

For the latest information about Graco products, visit [www.graco.com](http://www.graco.com).

**TO PLACE AN ORDER**, contact your Graco distributor or call to identify the nearest distributor.

**Phone:** 612-623-6921 **or Toll Free:** 1-800-328-0211 **Fax:** 612-378-3505

*All written and visual data contained in this document reflects the latest product information available at the time of publication. Graco reserves the right to make changes at any time without notice.*

Original instructions. This manual contains English. MM 3A0427

**Graco Headquarters:** Minneapolis

**International Offices:** Belgium, China, Japan, Korea

**GRACO INC. P.O. BOX 1441 MINNEAPOLIS, MN 55440-1441**

**Copyright 2010, Graco Inc. is registered to ISO 9001**

[www.graco.com](http://www.graco.com)