

Low Flow Regulator

Precise Fluid Control at Desired Flow Rates



Maintain consistent fluid regulation for automatic finishing applications

- Stainless wetted parts
- Springless fluid path prevents trapped material and allows easy cleaning
- High flow bypass to allow fast cleaning
- Low volume fluid section minimizes flush volume and time
- One of the most compact air-piloted fluid regulator designs on the market

For more information, visit our website at www.graco.com

PROVEN QUALITY. LEADING TECHNOLOGY.



Low Flow Regulator Features

Technical Specifications:

Height..... 100 mm (3.94 in)
 Diameter..... 46 mm (1.81 in)
 Max. Air Pressure 7 bar (100 psi)
 Max. Fluid Input 20.6 bar (300 psi)
 Fluid Output
 1:1 0.06 – 6.2 bar (1 – 90 psi)
 1:2 0.06 – 3.4 bar (1 – 50 psi)
 1:3 0.06 – 2.0 bar (1 – 30 psi)
 Hi-Port (all models) 0.06 – 6.2 bar (1 – 90 psi)

Pneumatic and Fluid Connections:

Air Pilot..... 4 mm (5/32 in) OD tube
 Air Override 4 mm (5/32 in) OD tube
 Fluid In 1/4 – 18 NPT(m)
 Fluid Out..... 1/8 – 27 NPT(f)

Ordering information:

Ratio	Ratio Spacer	Part Number
1:1	Silver	24C375
1:2	Green	24E471
1:3	Black	24E472

Conversion Kits:

(includes piston parts and air diaphragm)

Ratio	Ratio Spacer	Part Number
1:1	Silver	24E501
1:2	Green	24E502
1:3	Black	24E503

Service Kits:

- 24E504 **Seal Kit**
 Includes diaphragms, seat and o-ring seals
- 24F140 **Seat Kit**
 Includes seat, needle and seat retainer

GRACO N.V. Industrieterrein Oude Bunders
 Slakweidestraat 31 • B-3630 Maasmechelen
 Tel: +32 (89) 770 700 • Fax: +32 (89) 770 777
 E-mail: info@graco.be • http://www.graco.com

©2010 Graco Inc. Form No. 344836 Rev. A 08/10. All other brand names or marks are used for identification purposes and are trademarks of their respective owners. All written and visual data contained in this document are based on the latest product information available at the time of publication. Graco reserves the right to make changes at any time without notice.

- 1 Air Inlet
- 2 Air Bypass
- 3 Fluid Outlet (not included)
- 4 Stainless Steel Screws
- 5 Springless Fluid Path
- 6 Fluid Inlet

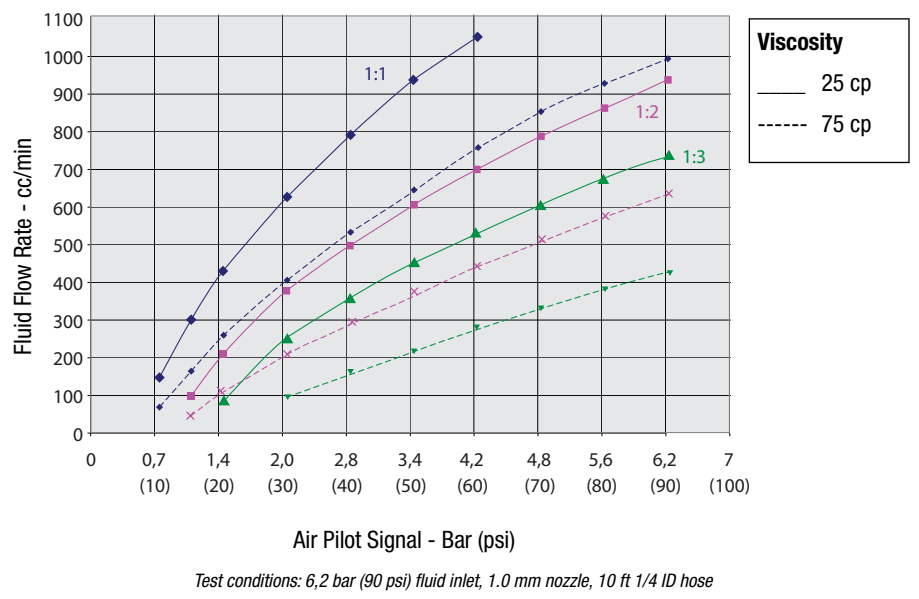
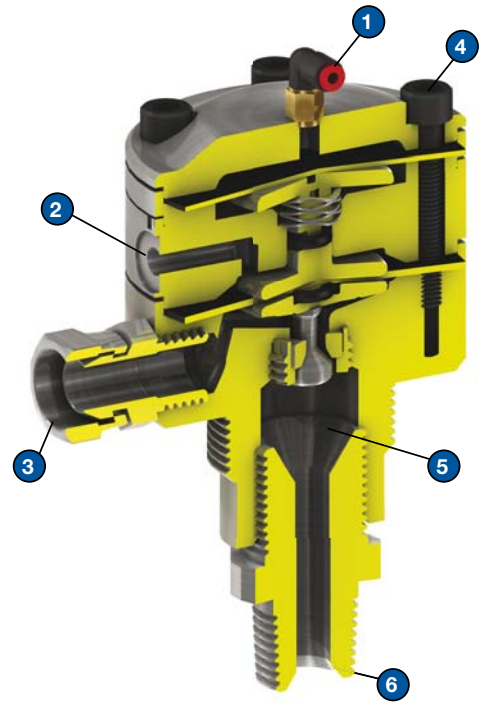

Applications

- Intricate finish details where precise control of fluid pressure is needed
- All automated applications for air operated fluid regulation
- Low flow rates/low viscosity applications



Graco's AirPro EFX™ Automatic Spray Gun automated air-operated application.