

BINKS DX SERIES

Air Operated 1:1 Ratio Diaphragm Pumps

DX70 is the perfect solution for one or two spray gun applications with faster colour changes and quick refills for less production downtime.



Acetal pump body with st. st. balls and soft seats
for universal paint compatibility including ceramic glaze coatings

The unique diaphragm design and "built in" fluid regulator
provide consistent pressure and readily adjustable paint flow

The Non-stall air valve
provides smooth, quiet and surge free paint delivery up to 1000 cc/ minute

Clearly labelled Air regulators
provide independent control of pump and spray gun fluid and air pressures

Quick release air, fluid inlet and outlet connections
for faster maintenance

Re-circulation/dump valve
accessory for faster colour changes reducing down time, saving time and money

Pump outfit mountings
include Cart, Wall, 25L Pail & Tripod outfits with or without spray guns & hoses

Outfits with Fluid filter
are available for finer paint finishes

Binks DX70 is the low cost solution compared to pressure tanks with no expensive annual pressure test certification regulations.

The DX70 is a high specification, air powered 1:1 ratio double diaphragm pump specifically developed for the direct supply of paints and materials to spray guns. The pump features a unique diaphragm no-crease shape for a long and durable working life DX70 also includes a "built-in" fluid regulator which ensures a constant and virtually pulse free fluid delivery, for direct feed to spray guns without the expense and complications of an additional fluid regulator or surge chamber.

The DX70 range features bare pumps, assembled pump packages and complete "ready to spray" outfits matched with our World renowned DeVilbiss spray guns. DX70 is perfect for use with ALL TYPES of spray gun technologies including, Conventional, Compliant Trans-Tech®, HVLV, LVLV and low pressure Electrostatic guns.

APPLICATIONS

- Woodworking and Joinery
- Aerospace Industry
- Agricultural and Off Road
- Potteries and Ceramic Glaze*
- Trade Coaters and Jobbers
- Marine Industry
- Truck and Bus
- Rail and Transport
- Plus Many Others:

TYPICAL MATERIAL/COATING TYPES

- Solvent and Water Based Paints and Materials
- Lacquers, Stains and Varnishes
- Adhesives and Fillers
- Ceramics and Glaze*
- Sealers and Undercoats
- Plus Many Others:

*The standard pump without fluid regulator can also be used on ceramic glaze applications.

BINKS
DX70

finishingbrands.eu



DX70 Diaphragm Pump Packages

The Binks DX70 range of packages are easily transportable and energy efficient, the air driven, 1:1 ratio double-diaphragm pump is available in a variety of fixed and mobile outfits to suit varying application requirements for industrial and automotive paints and coatings. The high quality construction of the pump ensures it can be used with virtually all solvent and water borne spray materials and there is a version specifically developed for use on Ceramic Glaze based materials.



Outfits include clearly identified air regulators which can independently control the pump, spray gun and fluid delivery pressures.

The pump outfits are fitted with a flexible suction wand or rigid suction tube with paint filter.

A stainless steel outlet fluid filter is available for finer paint finishes in mesh size 60 and 100* (*standard).

There is also an optional stainless steel pressure bypass dump valve assembly for faster colour changes and reducing down time.

DX70 provides fast fluid delivery of up to 1000cc per minute and is self priming.



The standard pump without fluid regulator can also be used on ceramic glaze applications.



DX70R3-CF Cart mounted pump outfit with filter and three air controls.



DX70R3-CFG Cart mounted pump with 6L gravity bucket feed, filter and three air controls.



DX70R3-T Tripod mounted pump outfit with three air controls.



DX70R3-WF Wall mounted pump with paint filter and three air controls (25L Pail not included).



DX70R3-PFA Pail mounted pump with agitator, filter and three air controls (25L Pail not included).



All DX pumps are covered by our extended five year "workmanship and materials" warranty.



The "built in" fluid regulator provides easily adjustable surge free paint flow. This feature costs extra on competitive models.



Fast maintenance - Non-stall air valve for smooth, quiet and consistent operation.



Bare pump part numbers

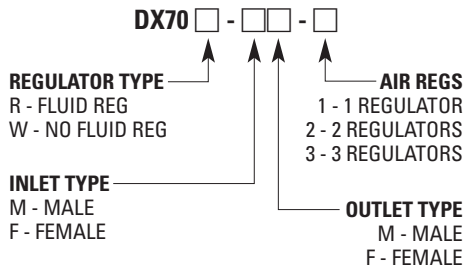

Outfit (no gun) part numbers

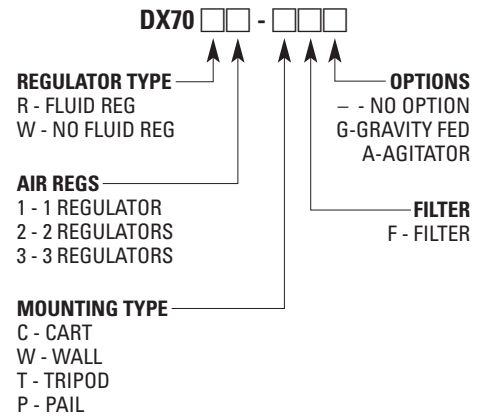

DX70 BARE PUMPS CONTENTS AND PART NUMBERS

	DX70R-MM3	DX70R-MF3	DX70R-FM3	DX70R-FF3	DX70N-MM2	DX70N-MF2	DX70N-FM2	DX70N-FF2	DX70N-MM1	DX70N-MF1	DX70N-FM1	DX70N-FF1	DX70R-MM	DX70R-MF	DX70R-FM	DX70R-FF	DX70N-MM	DX70N-MF	DX70N-FM	DX70N-FF	
DX70 Bare Pump Regulated M/M	•												•								
DX70 Bare Pump Regulated M/F		•												•							
DX70 Bare Pump Regulated F/M			•												•						
DX70 Bare Pump Regulated F/F				•												•					
DX70 Bare Pump No Reg M/M					•				•								•				
DX70 Bare Pump No Reg M/F						•				•								•			
DX70 Bare Pump No Reg F/M							•				•								•		
DX70 Bare Pump No Reg F/F								•				•								•	
Air Controls - 3 Regulators	•	•	•	•																	
Air Controls - 2 Regulators					•	•	•	•													
Air Controls - 1 Regulators									•	•	•	•									

DX70 PUMP OUTFIT CONTENTS AND PART NUMBERS

	DX70R3-C	DX70R3-CF	DX70N2-C	DX70N2-CF	DX70N1-C	DX70N1-CF	DX70R3-W	DX70R3-WF	DX70N2-W	DX70N2-WF	DX70N1-W	DX70N1-WF	DX70R3-T	DX70R3-TF	DX70N2-T	DX70N2-TF	DX70N1-T	DX70N1-TF	DX70R3-P	DX70R3-P	DX70N2-P	DX70N2-PF	DX70N1-P	DX70N1-PF	DX70R3-PA	DX70R3-PFA	DX70N2-PA	DX70N2-PFA	DX70R3-CG	DX70R3-CFG	DX70N2-CG	DX70N2-CFG	DX70N1-CG	DX70N1-CFG	DX70R3-WG	DX70R3-WFG	DX70N2-WG	DX70N2-WFG	DX70N1-WG	DX70N1-WFG	DX70R3-TG	DX70R3-TFG	DX70N2-TG	DX70N2-TFG	DX70N1-TG	DX70N1-TFG					
DX70 Bare Pump	•	•	•	•	•	•	•	•	•	•	•	•	•	•	•	•	•	•	•	•	•	•	•	•	•	•	•	•	•	•	•	•	•	•	•	•	•	•	•	•	•	•	•	•	•	•	•	•			
Fluid Regulator	•	•					•	•					•	•					•	•					•	•									•	•					•	•									
Filter Assembly		•																																																	
Suction Hose Assembly	•	•	•	•	•	•	•	•	•	•	•	•	•	•	•	•	•	•	•	•	•	•	•	•	•	•	•	•	•	•	•	•	•	•	•	•	•	•	•	•	•	•	•	•	•	•	•	•	•	•	•
Air Controls - 3 Regulators	•	•					•	•					•	•					•	•					•	•									•	•					•	•									
Air Controls - 2 Regulators			•	•					•	•					•	•					•	•					•	•								•	•					•	•								
Air Controls - 1 Regulator					•	•					•	•					•	•									•	•										•	•												
Pail Mounted																			•	•	•	•	•	•	•	•	•	•	•	•	•	•	•	•	•	•	•	•	•	•	•	•	•	•	•	•	•	•	•	•	
Tripod Mounted													•	•	•	•	•	•																																	
Cart Mounted	•	•	•	•	•	•																																													
Wall Mounted							•	•	•	•	•	•																																							
Gravity Feed																																																			
Agitator																																																			
			Cart Mounted				Wall Mounted				Tripod Mounted				Pail Mounted				Gravity Cart Mounted				Gravity Wall Mounted				Gravity Tripod Mounted																								



1. Stainless Steel fluid filter with mesh sizes 60 and 100* (*100 mesh supplied as standard).



2. CE & ATEX approved with Earthing/grounding cable as standard.



3. All suction pick up tubes include stainless steel strainers.



4. Optional re-circulation dump valve assembly.



5. Unique quick release air, fluid inlet and outlet connections for easy, faster servicing.

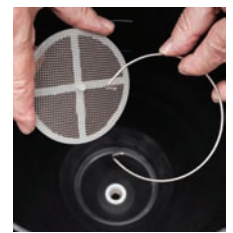

6. Gravity feed outfits include strainer inside the bucket.





Scan QR Code for more product information.

DX70 Ready Assembled Spray Outfits including Spray Guns

The DX70 spray outfits are available with either Advance HD or FLG 5 Trans-Tech® or Conventional spray guns. Outfits are delivered with 7.5 metres of air and fluid hoses and are ready to spray apart from connecting the guns and hoses as necessary.



DX70 Ready assembled spray gun outfits. Part no's:

- DX70R3-TF-FLG5 Tripod mounted pump outfit with FLG5 gun
- DX70R3-CF-FLG5 Cart mounted pump outfit with FLG5 gun
- DX70R3-TF-ADV Tripod mounted pump outfit with Advance gun
- DX70R3-CF-ADV Cart mounted pump outfit with Advance gun

Spray gun outfits include three air controls, 7.5M air and fluid hoses and fluid filter assembly with Advance HD Spray Gun Trans-Tech® (1.4mm tip with 510 air cap) **OR** FLG5 Spray Gun Trans-Tech® (1.4mm tip with 622 air cap).



DEVILBISS



DXA-RP Fluid regulator full pressure flush valve assembly.

DX70 PUMP SPECIFICATION (BARE PUMP)

Pump Ratio	1 to 1
Max. Air Pressure	7 Bar / 100 PSI
Max. Fluid Pressure	7 Bar / 100 PSI
Nominal Flow Volume / Cycle	0.07 Litres (0.018 US Gall)
Fluid Output @ 60 cycles/min	4.2 Litres / min (1.1 US Gall / min)
Max Recommended Continuous Cycle Rate	10 Cycles /min
Max Recommended Intermittent Cycle Rate	30 Cycles /min
Inlet Fluid Connection	3/8" Universal (BSPP/NPSM) Male or Female
Outlet Fluid Connection	3/8" Universal (BSPP/NPSM) Male or Female
Maximum Dry/Wet Lift	6.6m (21.8 feet)
Air Inlet	G1/4" (BSPP) Female
Fluid Regulator Pilot	Ø4 Tube
Air Volume / cycle @ 6.9Bar/100psi	0.77L (0.027SCFM)
Air Flow @ 10 cycles/min 6.9 bar/100psi	7.7L/min (0.27SCFM/min)
Air Flow @ 30 cycles/min 6.9 bar/100psi	23.2L/min (0.82SCFM/min)
Air Quality ISO 8573.1 Class 3.3.2 #	Dirt 5 microns Water -20°C@7bar (940ppm) Oil 0.1mg/m ³ Non Lubricated
Noise Level	68db LAeq
Earth (Air Inlet Cover)	<1Ω
Weight – Bare Pump	2.2 Kg (4.9 lbs)



BINKS DX SERIES 5-YEAR WARRANTY

Binks® warrants to the original end-use purchaser that the Binks branded products "DX" shall not fail under normal use and service due to a defect in material or workmanship within five (5) years from the date of shipment from Binks. Does not include normal wear and tear parts.

For further technical information please refer to the Binks DX70 Diaphragm Pumps Service Bulletin.

Sales and Service through our Global Network of Industrial Distributors

Binks International Offices

- Americas: **USA** ▪ **Mexico** ▪ **Brazil**
- Europe/Asia/Africa: **United Kingdom** ▪ **France** ▪ **Germany**
- Pacific Rim: **China** ▪ **Japan** ▪ **Australia**



www.finishingbrands.eu

email: marketing@finishingbrands.eu

