

MX432 Bare Pump Assemblies

Models: MX432PL (PTFE/LEATHER), MX432PP (PTFE), MX432PU (PTFE/UHMW), MX432UC (U-CUPS)

Patent 7,603,855

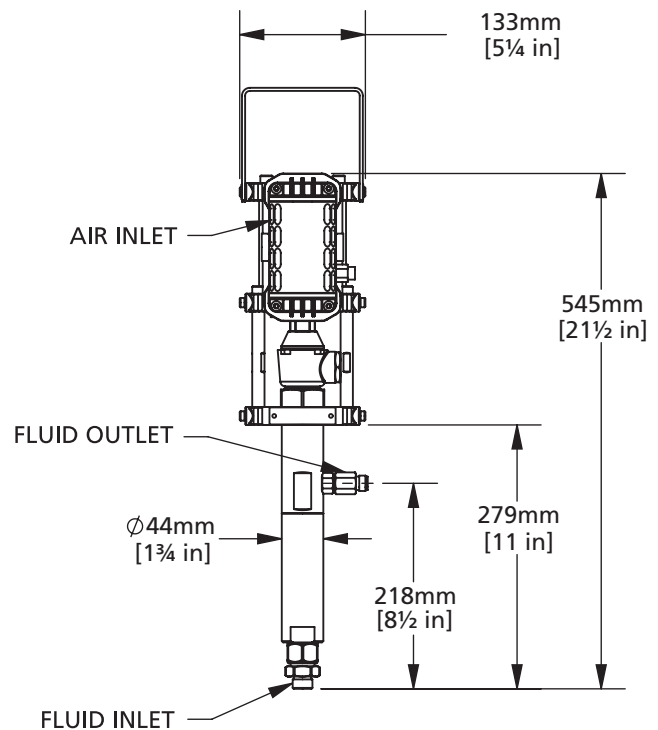
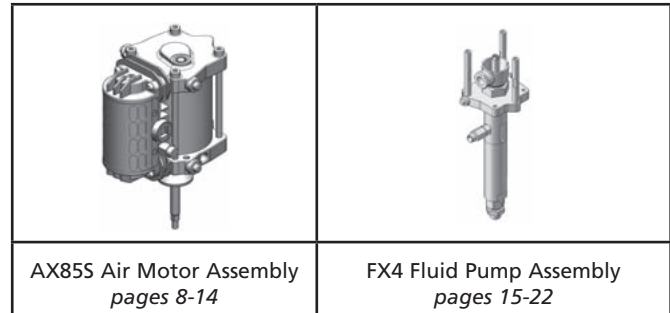
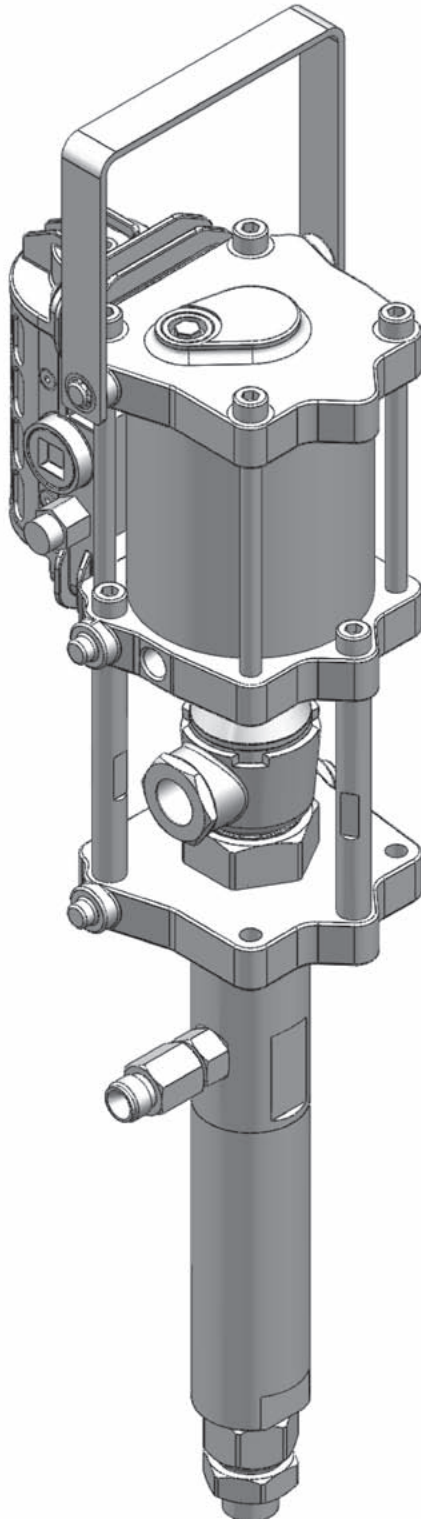

SPECIFICATIONS

Ratio:	32:1
Maximum air inlet pressure:	8 bar [116 psi]
Maximum fluid pressure:	256 bar [3712 psi]
Displacement per cycle:	24 cc [0.8 oz]
Output @ 60 cycles/min:	1.4 L/m [0.4 gal/m]
Air consumption @ 20 cycles/min:	147 LPM [5.2 SCFM]
Maximum recommended continuous cycle rate:	20 cycles/min
Air inlet connection:	3/8" BSP(f)
Fluid inlet connection:	1/2" NPS(m)
Fluid outlet connection:	3/8" BSP(m) and 3/8" NPS(m)
Sound level:	96.2 dB
Weight:	7 kg [15.4 lbs]

In this part sheet, the words **WARNING**, **CAUTION** and **NOTE** are used to emphasize important safety information as follows:

⚠ WARNING
 Hazards or unsafe practices which could result in severe personal injury, death or substantial property damage.

⚠ CAUTION
 Hazards or unsafe practices which could result in minor personal injury, product or property damage.

NOTE
 Important installation, operation or maintenance information.

⚠ WARNING

Read the following warnings before using this equipment.



READ THE MANUAL
 Before operating finishing equipment, read and understand all safety, operation and maintenance information provided in the operation manual.



WEAR SAFETY GLASSES
 Failure to wear safety glasses with side shields could result in serious eye injury or blindness.



DE-ENERGIZE, DEPRESSURIZE, DISCONNECT AND LOCK OUT ALL POWER SOURCES DURING MAINTENANCE
 Failure to De-energize, disconnect and lock out all power supplies before performing equipment maintenance could cause serious injury or death.



OPERATOR TRAINING
 All personnel must be trained before operating finishing equipment.



EQUIPMENT MISUSE HAZARD
 Equipment misuse can cause the equipment to rupture, malfunction, or start unexpectedly and result in serious injury.



KEEP EQUIPMENT GUARDS IN PLACE
 Do not operate the equipment if the safety devices have been removed.

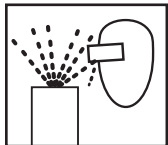

PROJECTILE HAZARD
 You may be injured by venting liquids or gases that are released under pressure, or flying debris.



PINCH POINT HAZARD
 Moving parts can crush and cut. Pinch points are basically any areas where there are moving parts.



PACEMAKER WARNING
 You are in the presence of magnetic fields which may interfere with the operation of certain pacemakers.



AUTOMATIC EQUIPMENT
 Automatic equipment may start suddenly without warning.



INSPECT THE EQUIPMENT DAILY
 Inspect the equipment for worn or broken parts on a daily basis. Do not operate the equipment if you are uncertain about its condition.



NEVER MODIFY THE EQUIPMENT
 Do not modify the equipment unless the manufacturer provides written approval.



KNOW WHERE AND HOW TO SHUT OFF THE EQUIPMENT IN CASE OF AN EMERGENCY



PRESSURE RELIEF PROCEDURE
 Always follow the pressure relief procedure in the equipment instruction manual.



NOISE LEVELS
 The A-Weighted sound level of pumping equipment and spray guns may exceed 85 dB (A) depending on the set-up being used. Details of actual noise levels are available on request. It is recommended that ear protection is worn at all times when spraying while pump is operating.



HIGH PRESSURE CONSIDERATION
 High pressure can cause serious injury. Relieve all pressure before servicing. Spray from the spray gun, hose leaks, or ruptured components can inject fluid into your body and cause extremely serious injury.



STATIC CHARGE
 Fluid may develop a static charge that must be dissipated through proper grounding of the equipment, objects to be sprayed and all other electrically conductive objects in the dispensing area. Improper grounding or sparks can cause a hazardous condition and result in fire, explosion or electric shock and other serious injury.

IT IS THE RESPONSIBILITY OF THE EMPLOYER TO PROVIDE THIS INFORMATION TO THE OPERATOR OF THE EQUIPMENT.

FOR FURTHER SAFETY INFORMATION REGARDING BINKS AND DEVILBISS EQUIPMENT, SEE THE GENERAL EQUIPMENT SAFETY BOOKLET (77-5300).

! WARNING



HIGH PRESSURE CAN CAUSE SERIOUS INJURY IF EQUIPMENT IS INSTALLED OR USED INCORRECTLY—READ, UNDERSTAND, AND OBSERVE ALL WARNINGS AND INSTRUCTIONS IN THIS MANUAL.

INSTALL, OPERATE OR SERVICE THIS EQUIPMENT ONLY AFTER ALL INSTRUCTIONS ARE CLEARLY UNDERSTOOD.

It is the responsibility of the employer to place this information into the hands of the operator.

! WARNING
Hazards or unsafe practices which could result in severe personal injury, death or substantial property damage.

! CAUTION
Hazards or unsafe practices which could result in minor personal injury, product or property damage.

NOTE
Important installation, operation or maintenance information.

AVOID STATIC SPARKING

1. Use Binks **NO-WIRE** conductive hose in all airless spraying operations. Be sure the gun and hose have continuity.
2. Make sure the pump is grounded. **NEVER** operate the unit when it is on a non-grounded platform.
3. When flushing or cleaning with a combustible solvent, always use an open metallic container for receiving the waste solvent. Ground the solvent receptacle.
4. **ALWAYS** remove spray tip when flushing the system. Operate the pump at the lowest possible pressure.

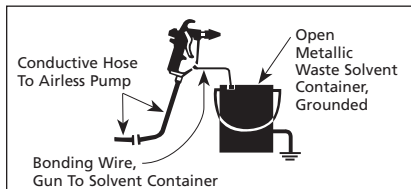

GENERAL WARNINGS

1. **NEVER** leave a pressurized sprayer unattended.
2. Periodically inspect all hoses for leaks and/or abrasions and tighten all connections before use. **DO NOT ATTEMPT TO REPAIR** a defective hose. **REPLACE** it with another conductive hose.
3. **ALWAYS** relieve pressure in the system by turning bypass valve to **BYPASS** or triggering spray gun before disassembly of any component parts.

CAUTION
Never store de-ionized, distilled, reverse osmosis or any pure grade of water in the pump. These fluids may cause corrosion.

NOTE
BINKS is not responsible for misapplication of pumps. Consult your BINKS representative for application assistance.

NOTE
Be sure that all fluids, solvents and fillers to be used are chemically and physically compatible with wetted parts in the pump. Consult your BINKS representative for pump materials of constructions and compatibility information. Consult the fluid manufacture for information regarding the fluids to be used.

REPLACEMENT PARTS

The pump is designed to use authorized parts only. When using this pump with parts that do not comply with the minimum specifications and safety devices of Binks, the user assumes all risks and liabilities.

! WARNING
EXCESSIVE AIR PRESSURE Can cause personal injury, pump damage or property damage. Do not exceed maximum inlet air pressure as stated on motor model plate.

HAZARD	CAUSE	SAFEGUARDS
<p>EXPLOSION</p> 	<p>STATIC ELECTRICITY</p> <p>Use of this equipment in a potentially explosive atmosphere.</p> <p>Vapors from flammable liquids can catch fire or explode from static electricity discharges.</p>	<ol style="list-style-type: none"> 1. If installing this equipment in a potentially explosive atmosphere, check the ATEX equipment category and temperature ratings meet the requirements for the zoned area. 2. Check electrical continuity of the air supply to earth— should be no greater than $10^6 \Omega$. 3. Electrically bond all metallic equipment to earth. Should be no greater than 1Ω.
<p>SPECIAL CONDITIONS FOR SAFE USE REQUIRED BY ATEX CERTIFICATION</p>	<p>Over pressurization of equipment can cause equipment failure or injury.</p> <p>Use lubricating medium resistant to carburisation.</p> <p>Improper operation or maintenance may create a hazard.</p>	<ol style="list-style-type: none"> 1. Do not exceed the stated maximum working pressures and motor speed as specified in this manual. 2. Only a suitably approved static dissipating or conductive air supply hoses shall be attached to the equipment and terminated to the air supply. 3. Air supplies (compressors, etc.) shall be sited in a non-hazardous area with a filter on the air intake system to prevent the ingress of dust or similar foreign material into the parts where compression takes place. 4. Use lubricating medium resistant to carburisation and has an auto ignition temperature of more than 185°C for T4 equipment. 5. User shall ensure all metallic parts of the equipment are suitably bonded to earth. Should be no greater than 1Ω.

EC Declaration of Conformity



We: ITW Finishing UK, Ringwood Rd., Bournemouth, Dorset, BH11 9LH, UK

As the manufacturer of the items listed below:

Piston Pumps MX412 MX432

Declare, under our sole responsibility, that, the equipment to which this document relates is in conformity with the following standards or other normative documents:

EN 13463-1:2009, EN 13463-5:2005, EN 982:1996 + A1:2008, EN 983:1996 + A1:2008 and EN 12621:2006

And thereby conform to the protection requirements of Council Directive 98/37/EC relating to **Machinery Safety Directive** and council Directive 94/9/EC relating to **Equipment and Protective Systems intended for use in Potentially Explosive Atmospheres**;

CE Ex 2 II Gc T4

Issued on: 1st July 2009

Authorized by:



General Manager

Technical file lodged with;
 TRL Compliance Ltd (Notified Body 0891)
 Moss View
 Nipe Lane
 Up Holland
 WN8 9PY, UK

MX432 BARE PUMP ASSEMBLIES

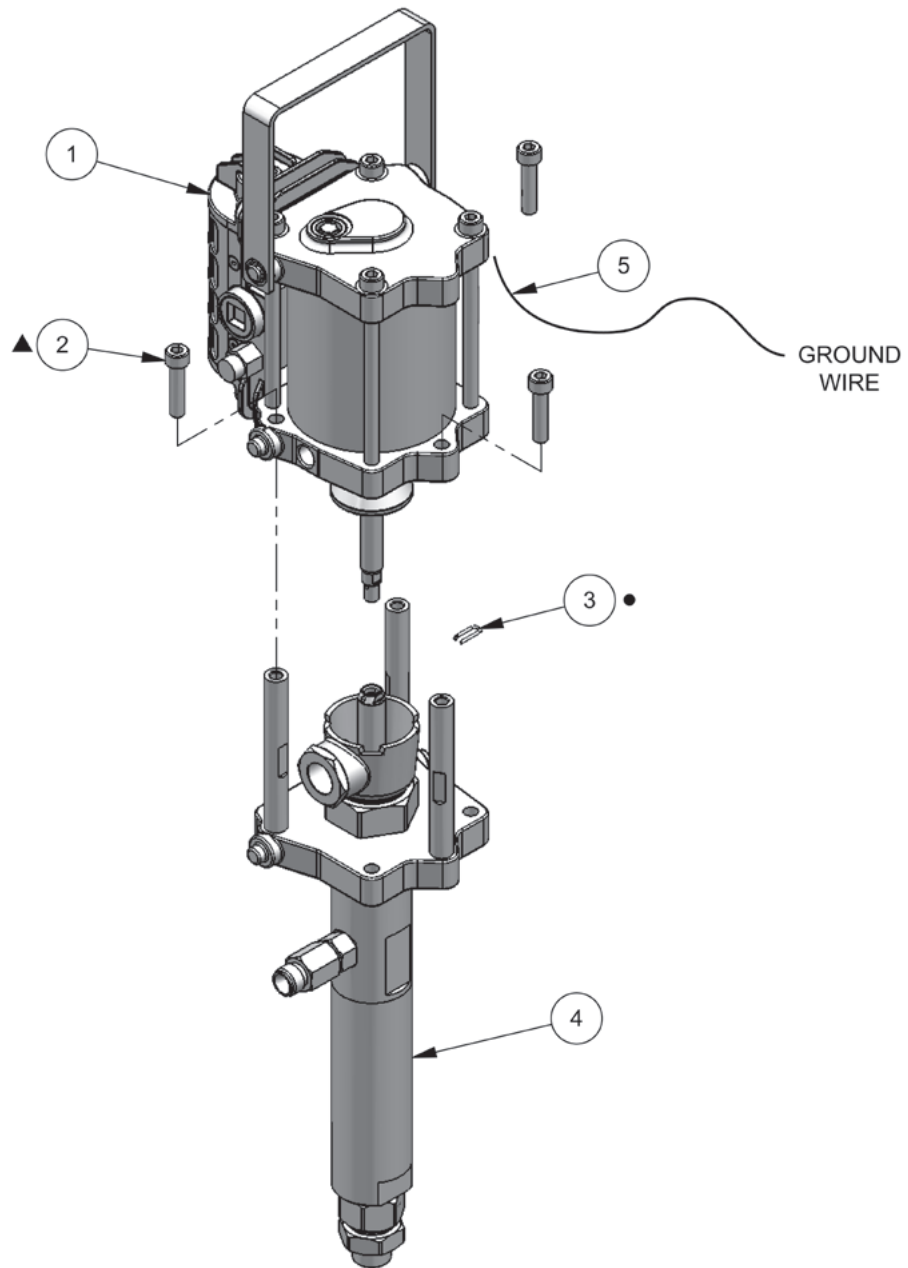

ITEM NO.	PART NUMBER	DESCRIPTION	MX432PL QTY.	MX432PP QTY.	MX432PU QTY.	MX432UC QTY.
1	AX85S	AX85S AIR MOTOR ASSEMBLY	1	1	1	1
2	0115-010001 ▲	SOCKET HEAD CAP SCREW	3	3	3	3
3	0115-010099 •	ROD CLIP	1	1	1	1
4	FX4PL	FX4 FLUID PUMP ASSEMBLY (PTFE/LEATHER)	1	–	–	–
4	FX4PP	FX4 FLUID PUMP ASSEMBLY (PTFE)	–	1	–	–
4	FX4PU	FX4 FLUID PUMP ASSEMBLY (PTFE/UHMW)	–	–	1	–
4	FX4UC	FX4 FLUID PUMP ASSEMBLY (U-CUPS)	–	–	–	1
5	0114-016243	GROUND WIRE KIT	1	1	1	1

• Part not sold separately. Available in repair kits: 0115-010220, 0115-010222 & 0115-010224.

▲ Part not sold separately. Available in AX85 hardware kit: 0115-010213.

MX432 BARE PUMP ASSEMBLIES – MAINTENANCE

MAINTENANCE SYMBOLS	
#	ITEM NUMBER
#	DISASSEMBLY ORDER <i>(Reverse order for assembly)</i>
PG	PETROLEUM JELLY/GREASE
TS	THREAD SEALANT <i>(PTFE tape)</i>

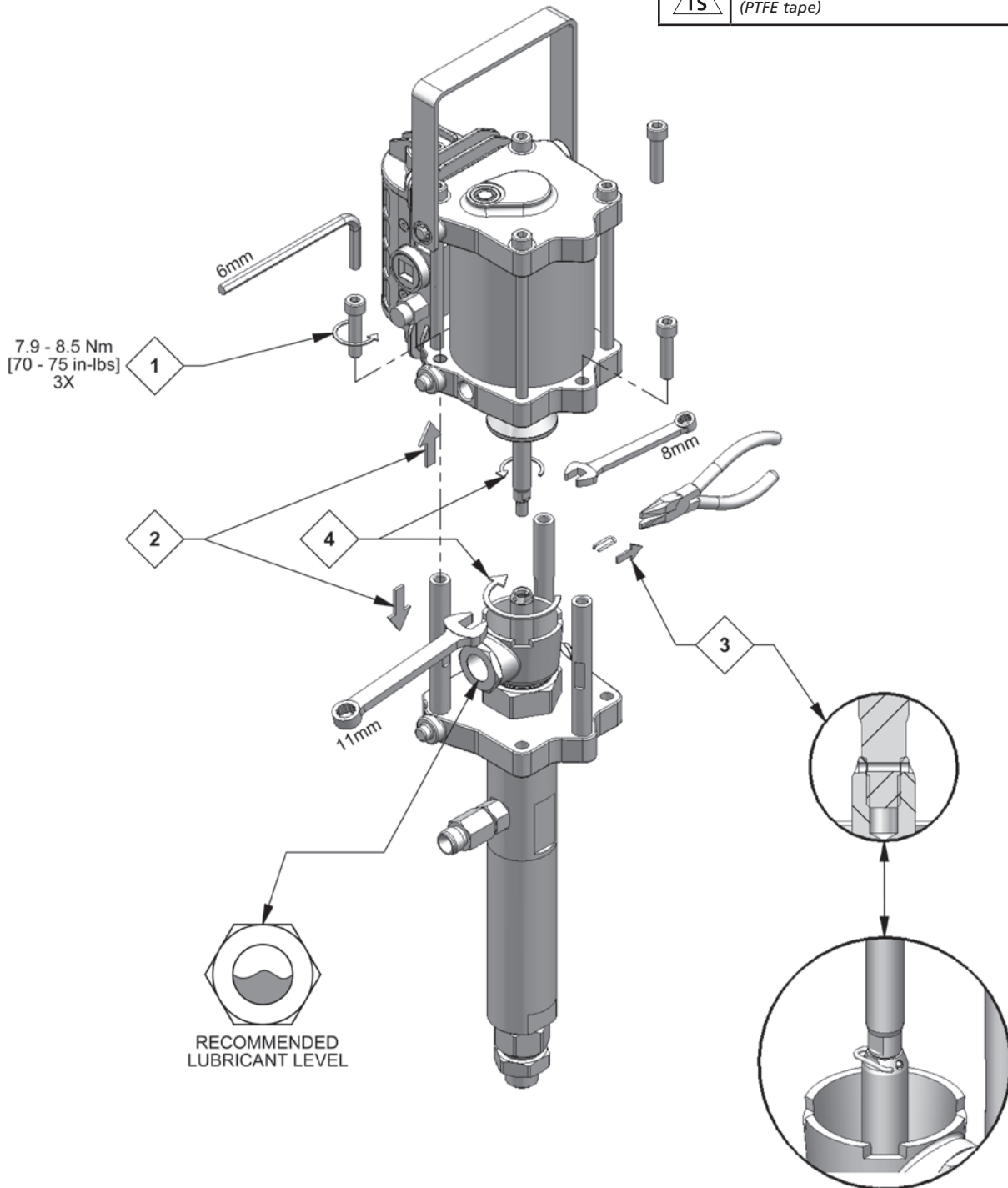

MX432 BARE PUMP ASSEMBLIES – TROUBLESHOOTING

PROBLEM	CAUSE	SOLUTION
Pump will not start	No compressed air. Spray tip is blocked.	Check compressed air supply. Clean or replace the spray tip.
Erratic operation of air motor, air motor stops	Worn poppet assemblies. Worn or dirty spool and sleeve assembly.	Replace the poppet assemblies. Clean or replace the spool and sleeve assembly, as necessary.
Continuous air leak from the exhaust	Worn poppet assemblies. Worn piston seal. Worn diaphragm.	Replace poppet assemblies. Replace piston seal. Replace diaphragm.
Material in solvent cup	Worn or dirty upper packings.	Replace or clean upper packings as necessary.
Pump does not stop on the down stroke	Worn or dirty lower ball check.	Replace or clean the parts as necessary.
Pump does not stop on the up stroke	Worn or dirty upper ball check. Worn or dirty lower packings.	Replace or clean the parts as necessary.
Pump runs erratically	Blocked siphon kit. Blocked inlet filter or strainer. Low material level.	Replace or clean the siphon kit. Replace or clean the inlet filter or strainer. Replace or refill material container.
Pump runs, with no output	Loose connection in between pump and siphon kit. Stuck lower ball.	Check that all connections are tight. Replace or clean the parts as necessary.

AX85S Air Motor Assembly

Patent 7,603,855

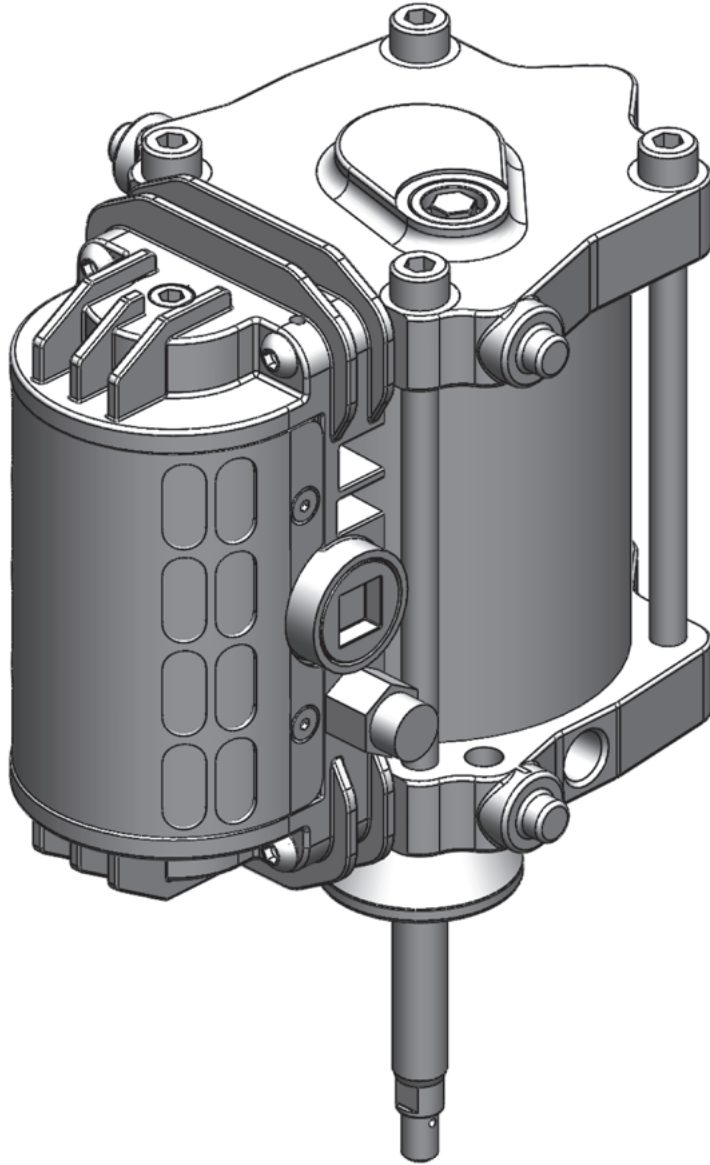

SPECIFICATIONS	
Maximum air inlet pressure:	8 bar [116 psi]
Maximum recommended continuous cycle rate:	20 cycles/min
Air inlet connection:	3/8" BSP(f)
Piston Diameter:	85 mm [3.3 in]
Stroke Length:	75 mm [3.0 in]

AX85S AIR MOTOR ASSEMBLY

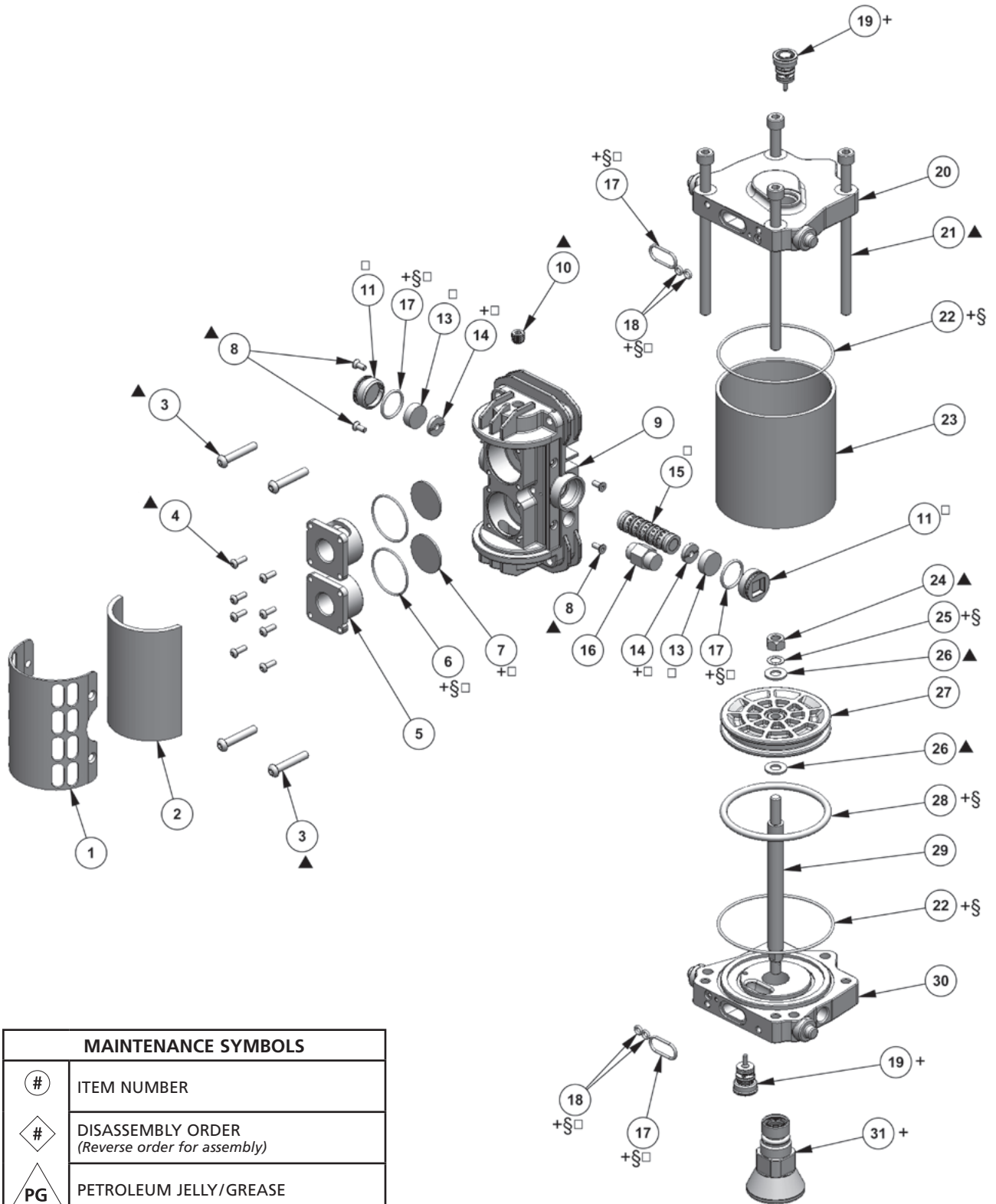

MAINTENANCE SYMBOLS	
#	ITEM NUMBER
#	DISASSEMBLY ORDER <i>(Reverse order for assembly)</i>
PG	PETROLEUM JELLY/GREASE
TS	THREAD SEALANT <i>(PTFE tape)</i>

- + Parts are included in 0115-010215 AX85 Repair Kit.
- § Parts are included in 0115-010217 AX85 Seal Kit.
- Parts are included in 0115-010226 Air Motor Valve Repair Kit.
- ▲ Parts are included in 0115-010213 AX85 Hardware Kit.

AX85S AIR MOTOR ASSEMBLY

ITEM NO.	PART NUMBER	DESCRIPTION	QTY.
1	0115-010023	EXHAUST COVER SCREEN	1
2	0115-010022	EXHAUST COVER	1
3	0115-010026 ▲	BUTTON HEAD CAP SCREW	4
4	0115-010073 ▲	BUTTON HEAD CAP SCREW	8
5	0115-010019	QUICK EXHAUST VALVE CAGE	2
6	0115-010021 +§□	O-RING	2
7	0115-010020 +□	DIAPHRAGM	2
8	0115-010024 ▲	FLAT HEAD COUNTER SUNK CAP SCREW	4
9	0115-010097	VALVE BLOCK	1
10	0115-010107 ▲	PIPE PLUG	1
11	0115-010018 □	VALVE BLOCK END CAP	2
13	0115-010017 □	MAGNET	2
14	0115-010016 +□	BUMPER	2
15	0115-010015 □	SPOOL AND SLEEVE ASSEMBLY	1
16	0114-014774	SAFETY VALVE	1
17	0115-010049 +§□	O-RING	4
18	0115-010051 +§□	O-RING	4
19	0115-010037 +	POPPET ASSEMBLY	2
20	0115-010004	UPPER END CAP MACHINING	1
21	0115-010029 ▲	SOCKET HEAD CAP SCREW	4
22	0115-010050 +§	CYLINDER SEAL, 85mm	2
23	0115-010003	CYLINDER, 85mm	1
24	0115-010096 ▲	LOCKNUT	1
25	0115-010036 +§	SEALING RING	1
26	0115-010035 ▲	FLAT WASHER	2
27	0115-010032	PISTON, 85mm	1
28	0114-014466 +§	PISTON SEAL, 85mm	1
29	0115-010034	MOTOR ROD	1
30	0115-010006	LOWER END CAP MACHINING	1
31	0115-010008 +	MOTOR ROD CARTRIDGE ASSEMBLY (INCLUDES SEALS)	1

+ Parts are included in 0115-010215 AX85 Repair Kit.

§ Parts are included in 0115-010217 AX85 Seal Kit.

□ Parts are included in 0115-010226 Air Motor Valve Repair Kit.

▲ Parts are included in 0115-010213 AX85 Hardware Kit.

AX85S AIR MOTOR ASSEMBLY – MAINTENANCE

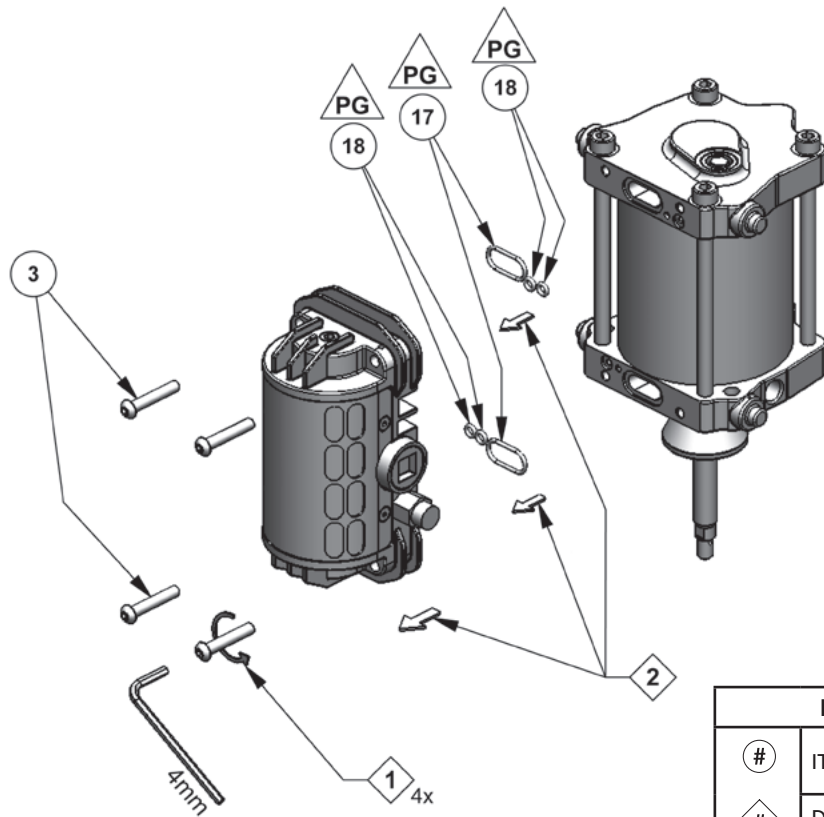

MAINTENANCE SYMBOLS	
#	ITEM NUMBER
#	DISASSEMBLY ORDER <i>(Reverse order for assembly)</i>
PG	PETROLEUM JELLY/GREASE
TS	THREAD SEALANT <i>(PTFE tape)</i>

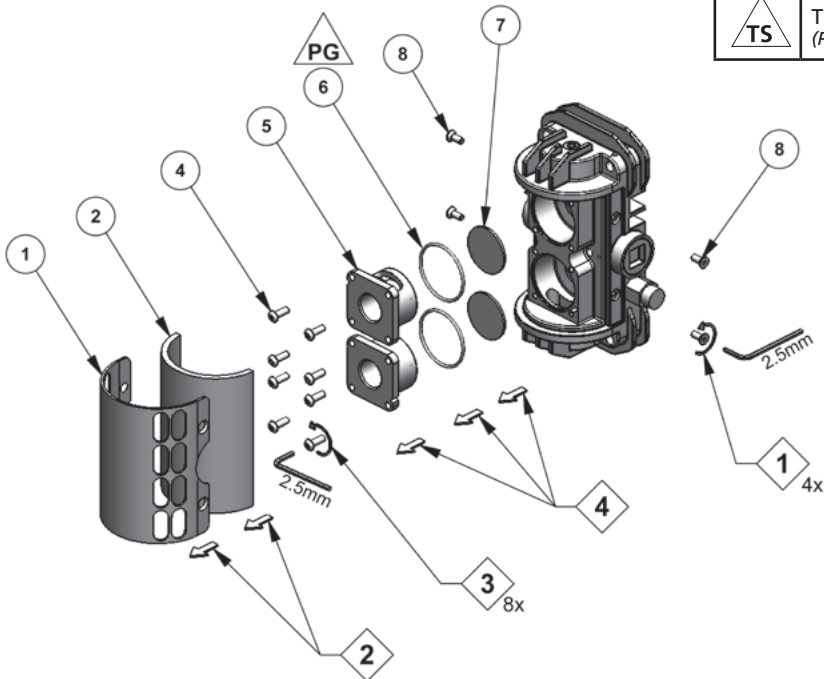

AX85S AIR MOTOR ASSEMBLY – MAINTENANCE

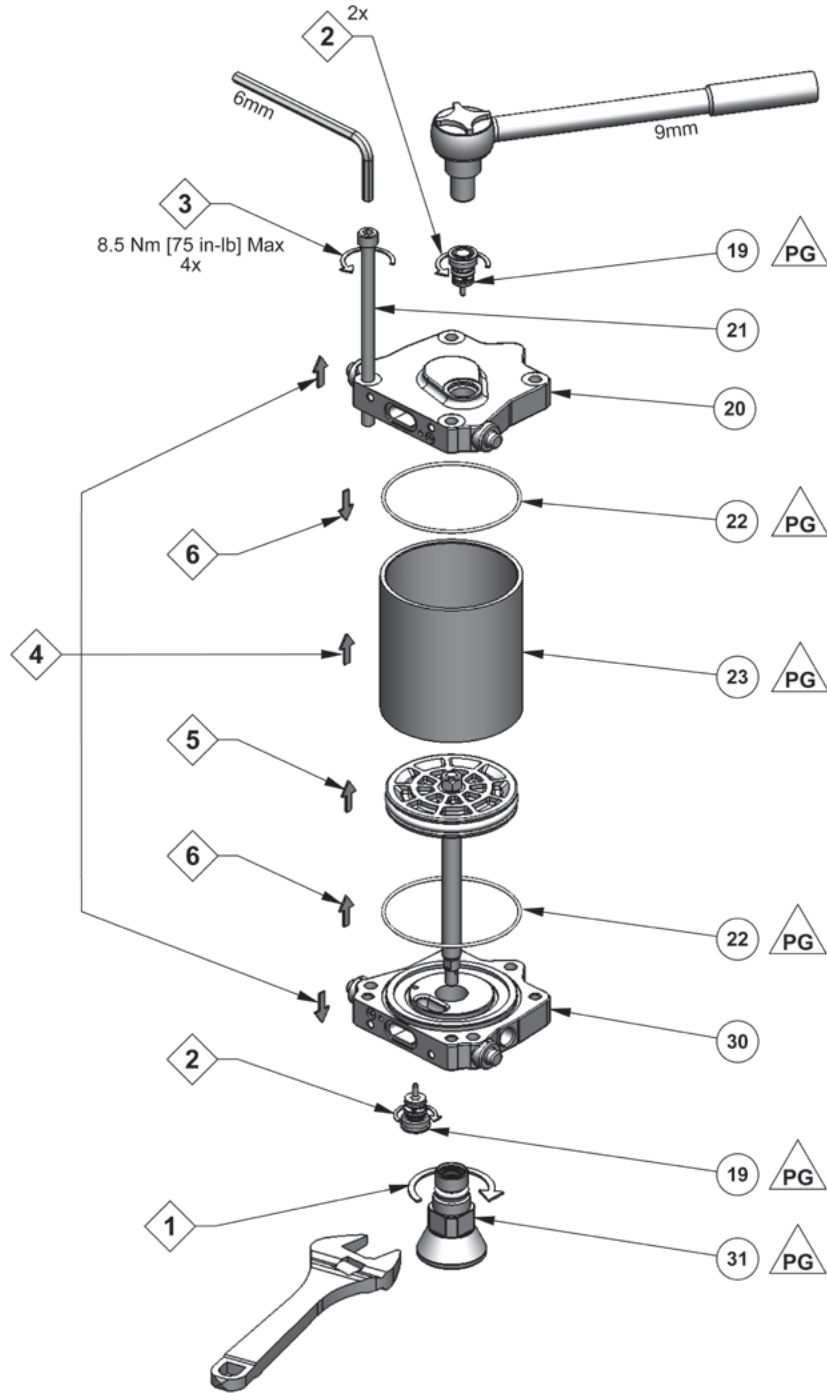

MAINTENANCE SYMBOLS	
#	ITEM NUMBER
#	DISASSEMBLY ORDER <i>(Reverse order for assembly)</i>
PG	PETROLEUM JELLY/GREASE
TS	THREAD SEALANT <i>(PTFE tape)</i>

AX85S AIR MOTOR ASSEMBLY – MAINTENANCE

⚠ DANGER

You are in the presence of magnetic fields which may interfere with the operation of certain pacemakers.

NOTE

Spool and sleeve assembly (15) is a matched set and cannot be interchanged with other spool and sleeve assemblies.

⚠ CAUTION

Take care when handling the magnets (13). Avoid getting magnets in close proximity to each other. Injury or damage to magnets may result.

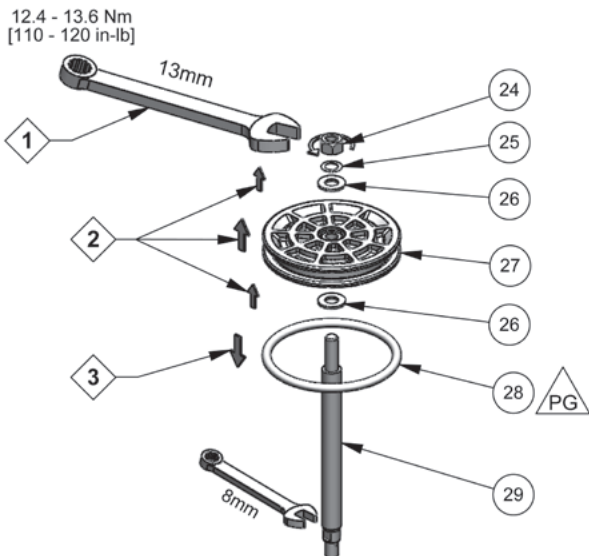
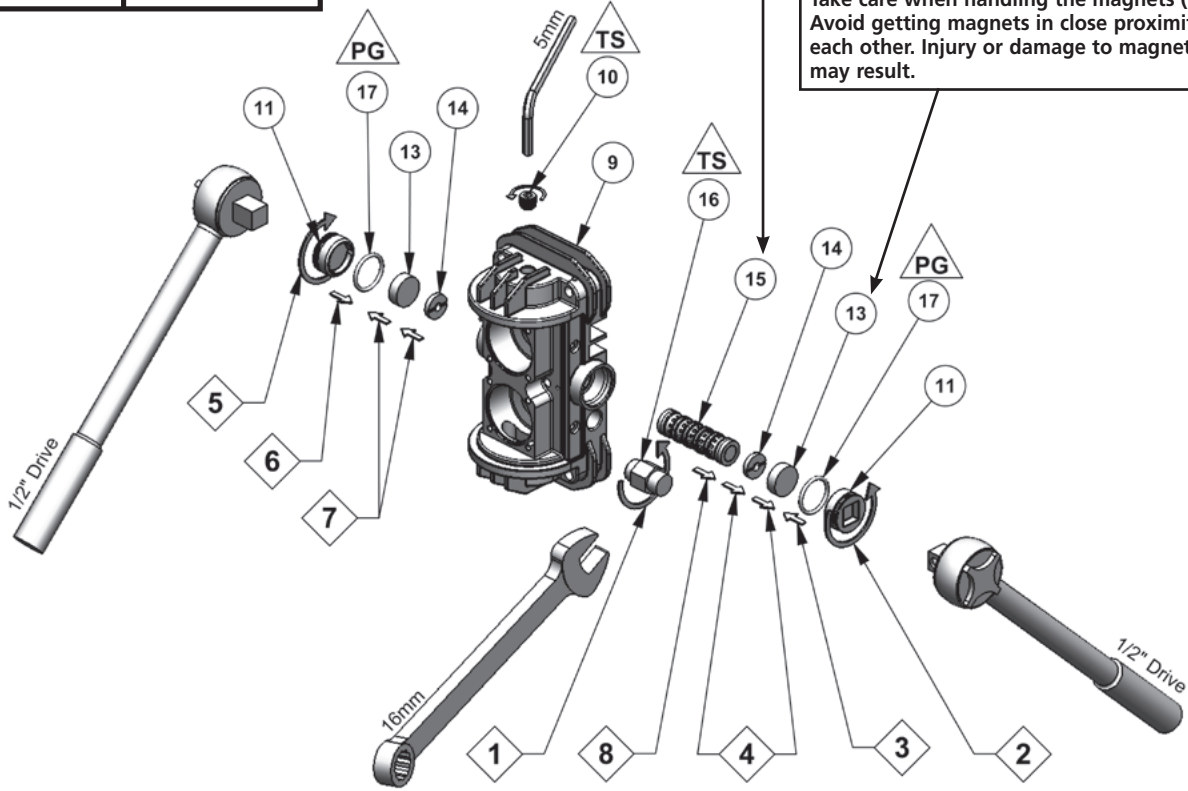

MAINTENANCE SYMBOLS	
#	ITEM NUMBER
#	DISASSEMBLY ORDER <i>(Reverse order for assembly)</i>
PG	PETROLEUM JELLY/GREASE
TS	THREAD SEALANT <i>(PTFE tape)</i>

AX85S AIR MOTOR ASSEMBLY – TROUBLESHOOTING

PROBLEM	CAUSE	SOLUTION
Pump will not start	No compressed air. System is blocked.	Check compressed air supply. Clear the blockage.
Erratic operation of air motor, air motor stops	Worn poppet assemblies. Worn or dirty spool and sleeve assembly.	Replace poppet assemblies. Clean or replace the spool and sleeve assembly as necessary.
Continuous air leak from the exhaust	Worn poppet assemblies. Worn piston seal. Worn diaphragm.	Replace poppet assemblies. Replace piston seal. Replace diaphragm.

FX4 Fluid Pump Assemblies

Models: FX4PL (PTFE/Leather), FX4PP (PTFE), FX4PU (PTFE/UHMW), FX4UC (U-Cups)

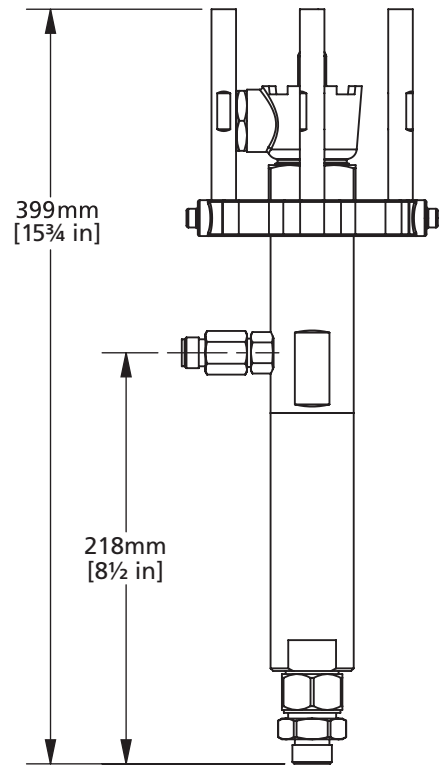
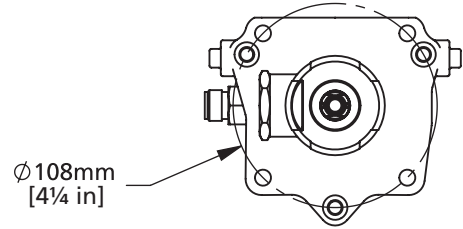
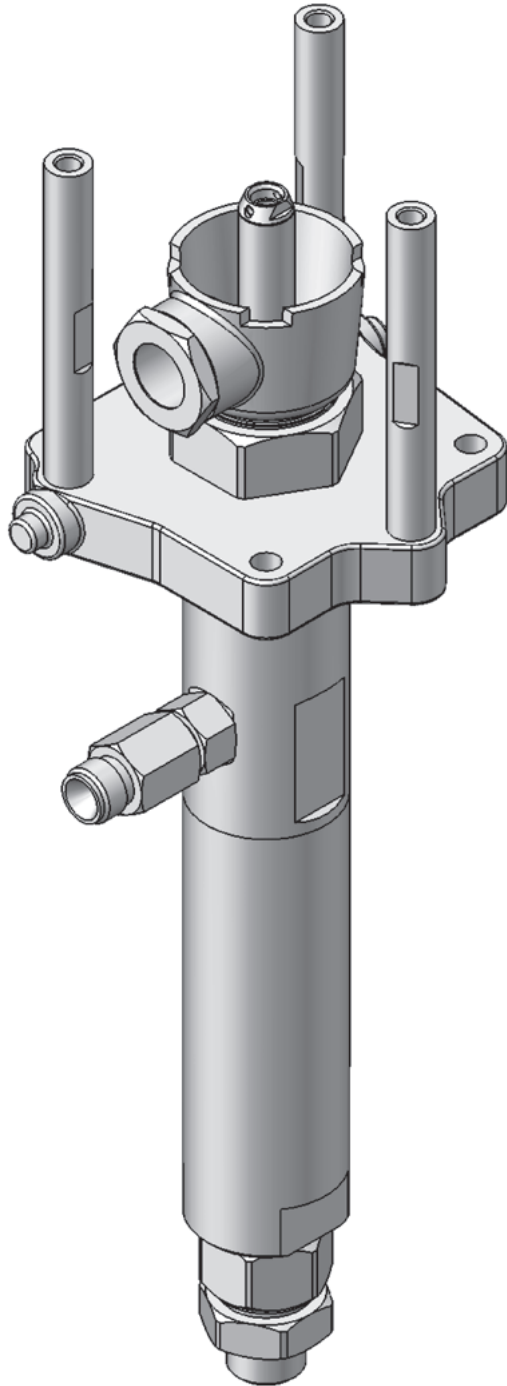

SPECIFICATIONS

Maximum fluid pressure:	256 bar [3712 psi]
Displacement per cycle:	24 cc [0.8 oz]
Output @ 60 cycles/min:	1.4 L/m [0.4 gal/m]
Fluid inlet size:	1/2" NPS(m)
Fluid outlet size:	3/8" NPSM(m)
Weight:	3.7 kg [8.1 lbs]
Wetted parts materials of construction:	Stainless Steel, Tungsten Carbide, Hard Chrome, PTFE, Polyethylene, Leather

FX4 FLUID PUMP ASSEMBLIES (CHEVRON PACKINGS)

Models: FX4PL (PTFE/Leather), FX4PP (PTFE), FX4PU (PTFE/UHMW)

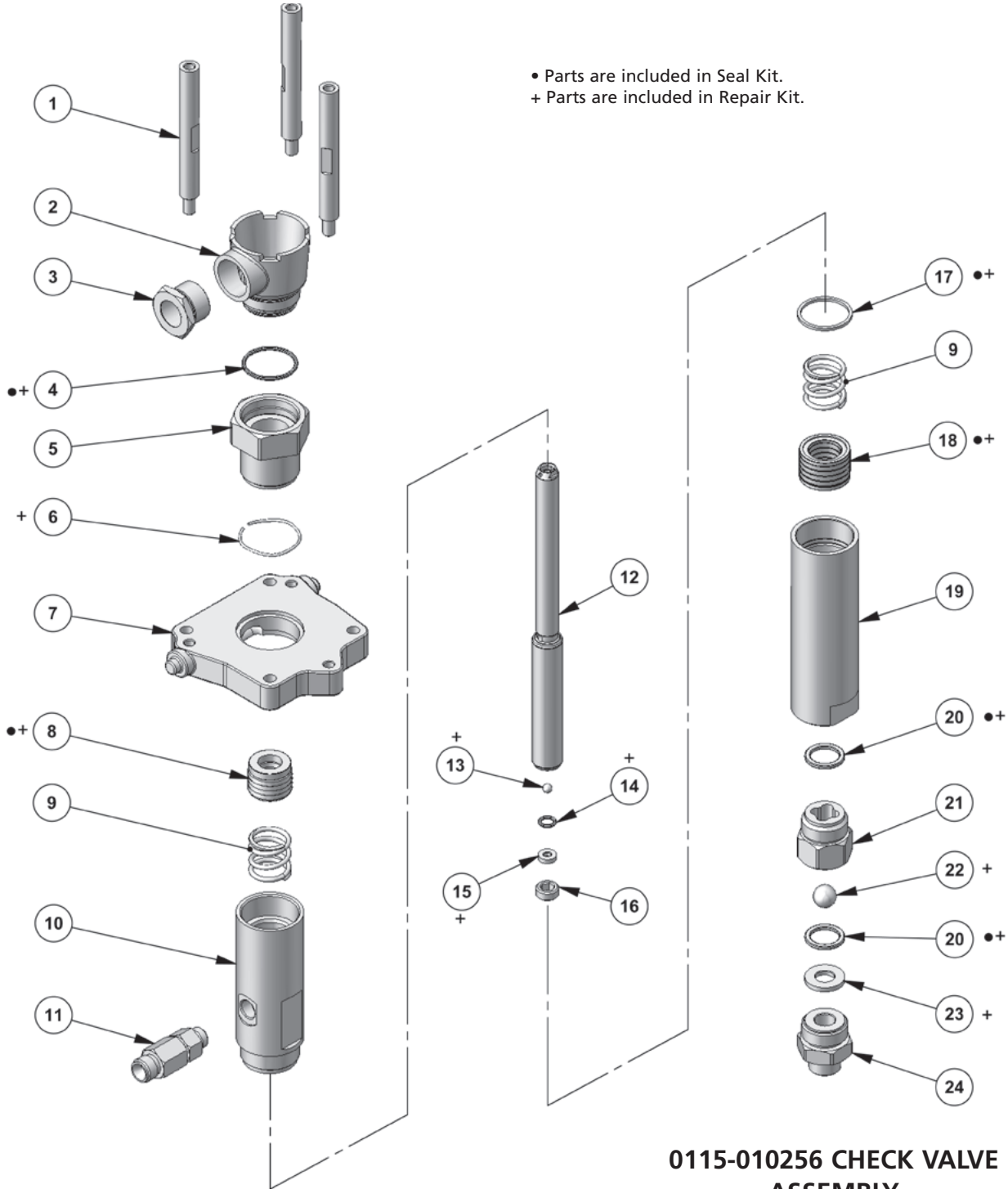

0115-010256 CHECK VALVE ASSEMBLY

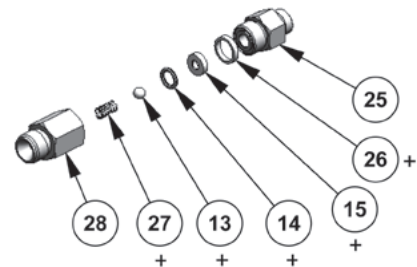

MAINTENANCE SYMBOLS	
#	ITEM NUMBER
#	DISASSEMBLY ORDER <i>(Reverse order for assembly)</i>
PG	PETROLEUM JELLY/GREASE
TS	THREAD SEALANT <i>(PTFE tape)</i>

FX4 FLUID PUMP ASSEMBLIES (CHEVRON PACKINGS)

Models: FX4PL (PTFE/Leather), FX4PP (PTFE), FX4PU (PTFE/UHMW)

ITEM NO.	PART NUMBER	DESCRIPTION	FX4PL QTY.	FX4PP QTY.	FX4PU QTY.
1	0115-010053	PUMP TIE ROD	3	3	3
2	0115-010059	SOLVENT CUP	1	1	1
3	0115-010060	SIGHT GAUGE	1	1	1
4	0115-010061 •+	SOLVENT CUP SEAL	1	1	1
5	0115-010062	PACKING ADAPTER	1	1	1
6	0115-010058 +	WAVE SPRING	1	1	1
7	0115-010204	ADAPTER PLATE MACHINING	1	1	1
8	0115-010171 •+	UPPER PACKING SET (PTFE/LEATHER)	1	-	-
	0115-010175 •+	UPPER PACKING SET (PTFE/UHMW)	-	-	1
	0115-010206 •+	UPPER PACKING SET (PTFE)	-	1	-
9	0115-010111	PACKING SPRING	2	2	2
10	0115-010055	UPPER PUMP TUBE	1	1	1
11	0115-010256	CHECK VALVE ASSEMBLY	1	1	1
12	0115-010063	PUMP ROD (HARD CHROME)	1	1	1
13	0114-014745 +	UPPER BALL, 6mm	2	2	2
14	0115-010065 +	ROD SEAT SEAL	2	2	2
15	0115-010066 +	ROD SEAT	2	2	2
16	0115-010067	ROD SEAT NUT	1	1	1
17	0115-010064 •+	LOWER PUMP TUBE SEAL	1	1	1
18	0115-010173 •+	LOWER PACKING SET (PTFE/LEATHER)	1	-	-
	0115-010177 •+	LOWER PACKING SET (PTFE/UHMW)	-	-	1
	0115-010207 •+	LOWER PACKING SET (PTFE)	-	1	-
19	0115-010056	LOWER PUMP TUBE	1	1	1
20	0115-010068 •+	LOWER SEAT SEAL	2	2	2
21	0115-010057	LOWER BALL CAGE	1	1	1
22	0114-014237 +	LOWER BALL, 15mm	1	1	1
23	0115-010069 +	LOWER SEAT	1	1	1
24	0115-010070	SEAT RETAINER	1	1	1
25	0115-010258	FLUID OUTLET FITTING	1	1	1
26	0115-010259 +	CHECK SEAL	1	1	1
27	0115-010087 +	VALVE SPRING	1	1	1
28	0115-010257	CHECK VALVE HOUSING	1	1	1
29	0115-010099 +	ROD CLIP (not shown)	1	1	1
• Parts are included in Seal Kit:			0115-010221	0115-010223	0115-010225
+ Parts are included in Repair Kit:			0115-010222	0115-010224	0115-010388

FX4 FLUID PUMP ASSEMBLIES (U-CUPS)

Models: FX4UC

- Parts are included in 0115-010219 Seal Kit (U-CUPS).
- + Parts are included in 0115-010220 Repair Kit (U-CUPS).

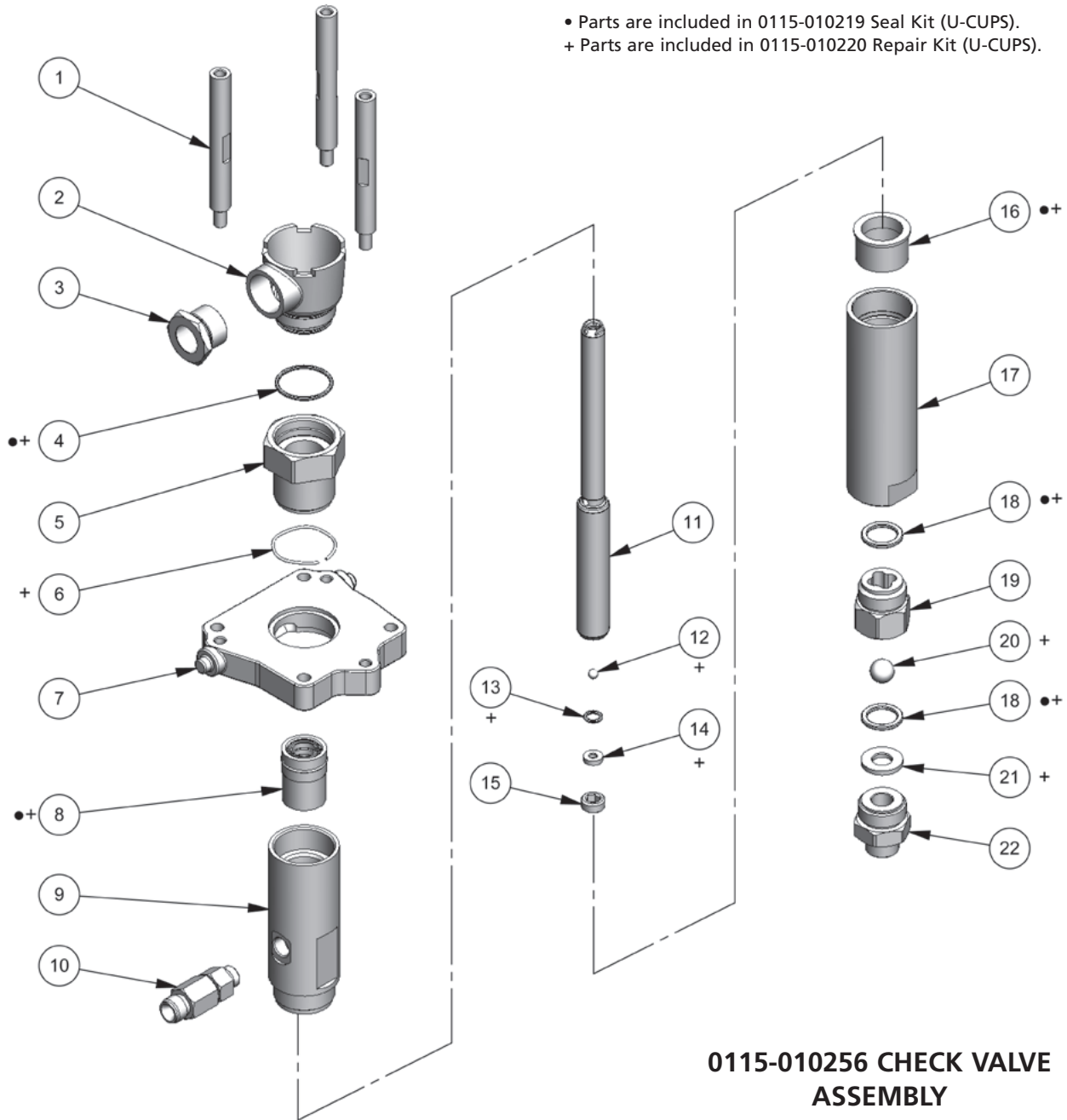

0115-010256 CHECK VALVE ASSEMBLY

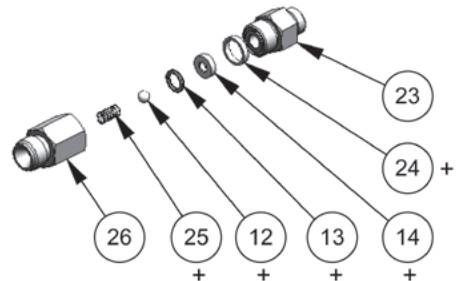

MAINTENANCE SYMBOLS	
#	ITEM NUMBER
#	DISASSEMBLY ORDER (Reverse order for assembly)
PG	PETROLEUM JELLY/GREASE
TS	THREAD SEALANT (PTFE tape)

FX4 FLUID PUMP ASSEMBLIES (U-CUPS)

Models: FX4UC

ITEM NO.	PART NUMBER	DESCRIPTION	QTY.
1	0115-010053	PUMP TIE ROD	3
2	0115-010059	SOLVENT CUP	1
3	0115-010060	SIGHT GAUGE	1
4	0115-010061 •+	SOLVENT CUP SEAL	1
5	0115-010062	PACKING ADAPTER	1
6	0115-010058 +	WAVE SPRING	1
7	0115-010204	ADAPTER PLATE MACHINING	1
8	0115-010166 •+	UPPER SEAL CARTRIDGE ASSEMBLY	1
9	0115-010055	UPPER PUMP TUBE	1
10	0115-010256	CHECK VALVE ASSEMBLY	1
11	0115-010063	PUMP ROD (HARD CHROME)	1
12	0114-014745 +	UPPER BALL, 6mm	2
13	0115-010065 +	ROD SEAT SEAL	2
14	0115-010066 +	ROD SEAT	2
15	0115-010067	ROD SEAT NUT	1
16	0115-010169 •+	LOWER SEAL CARTRIDGE ASSEMBLY	1
17	0115-010056	LOWER PUMP TUBE	1
18	0115-010068 •+	LOWER SEAT SEAL	2
19	0115-010057	LOWER BALL CAGE	1
20	0114-014237 +	LOWER BALL, 15mm	1
21	0115-010069 +	LOWER SEAT	1
22	0115-010070	SEAT RETAINER	1
23	0115-010258	FLUID OUTLET FITTING	1
24	0115-010259 +	CHECK SEAL	1
25	0115-010087 +	VALVE SPRING	1
26	0115-010257	CHECK VALVE HOUSING	1
27	0115-010099 +	ROD CLIP (not shown)	1

• Parts are included in 0115-010219 Seal Kit (U-CUPS).

+ Parts are included in 0115-010220 Repair Kit (U-CUPS).

FX4 FLUID PUMP (CHEVRONS) – MAINTENANCE

Models: FX4PL (PTFE/Leather), FX4PP (PTFE), FX4PU (PTFE/UHMW)

MAINTENANCE SYMBOLS	
#	ITEM NUMBER
#	DISASSEMBLY ORDER <i>(Reverse order for assembly)</i>
PG	PETROLEUM JELLY/GREASE
TS	THREAD SEALANT <i>(PTFE tape)</i>

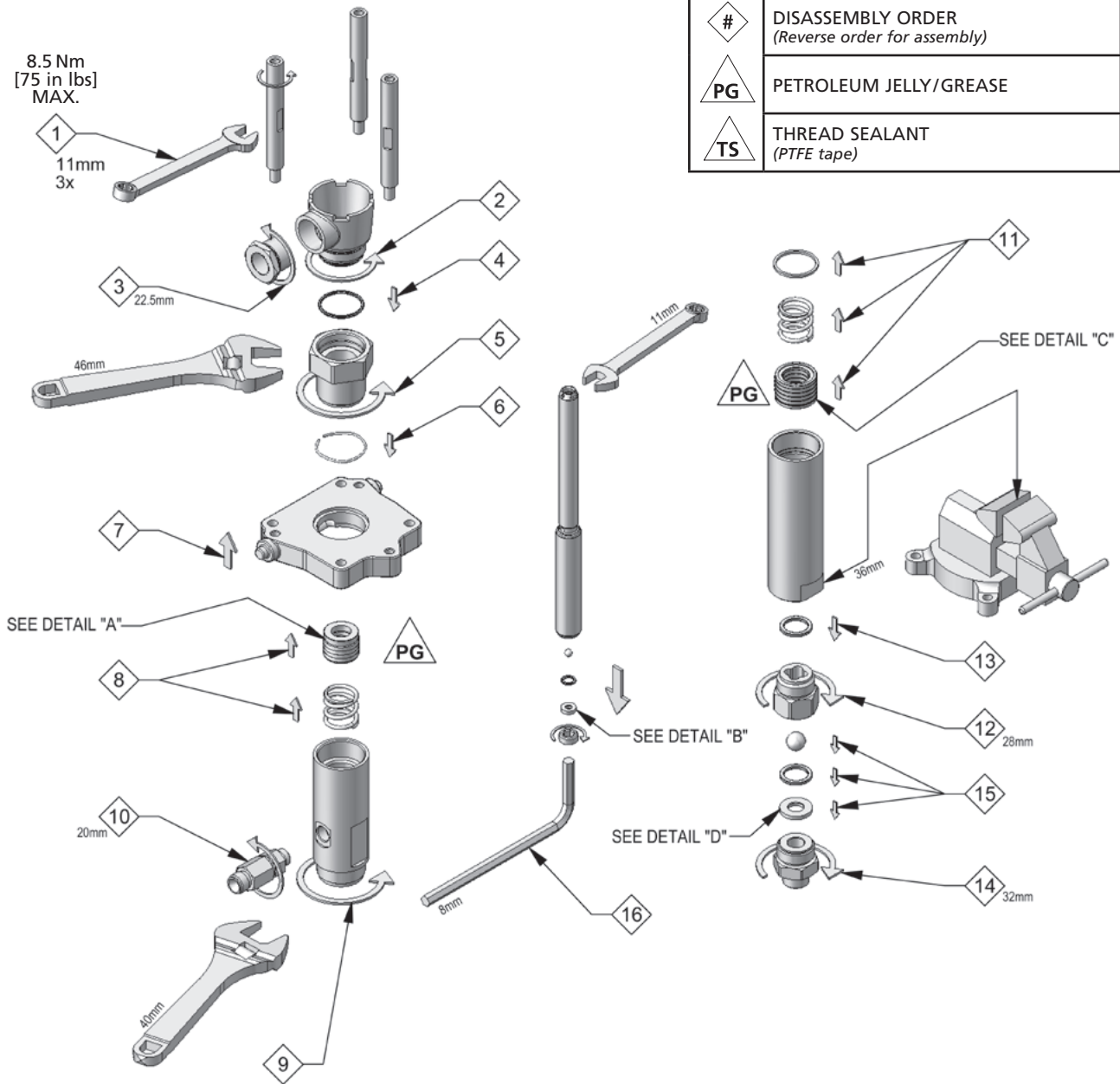

FX4 PACKING AND SEAT ORIENTATION

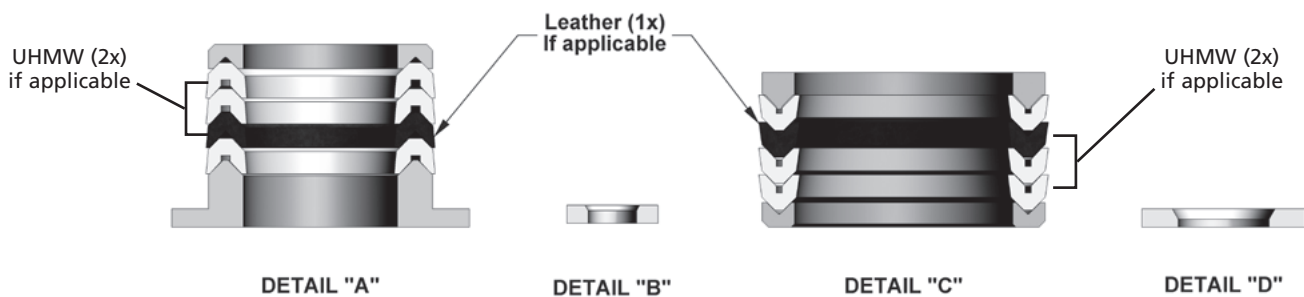

FX4 FLUID PUMP (U-CUPS) – MAINTENANCE

Models: FX4UC

MAINTENANCE SYMBOLS	
#	ITEM NUMBER
#	DISASSEMBLY ORDER <i>(Reverse order for assembly)</i>
PG	PETROLEUM JELLY/GREASE
TS	THREAD SEALANT <i>(PTFE tape)</i>

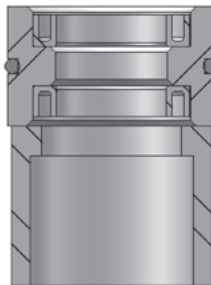
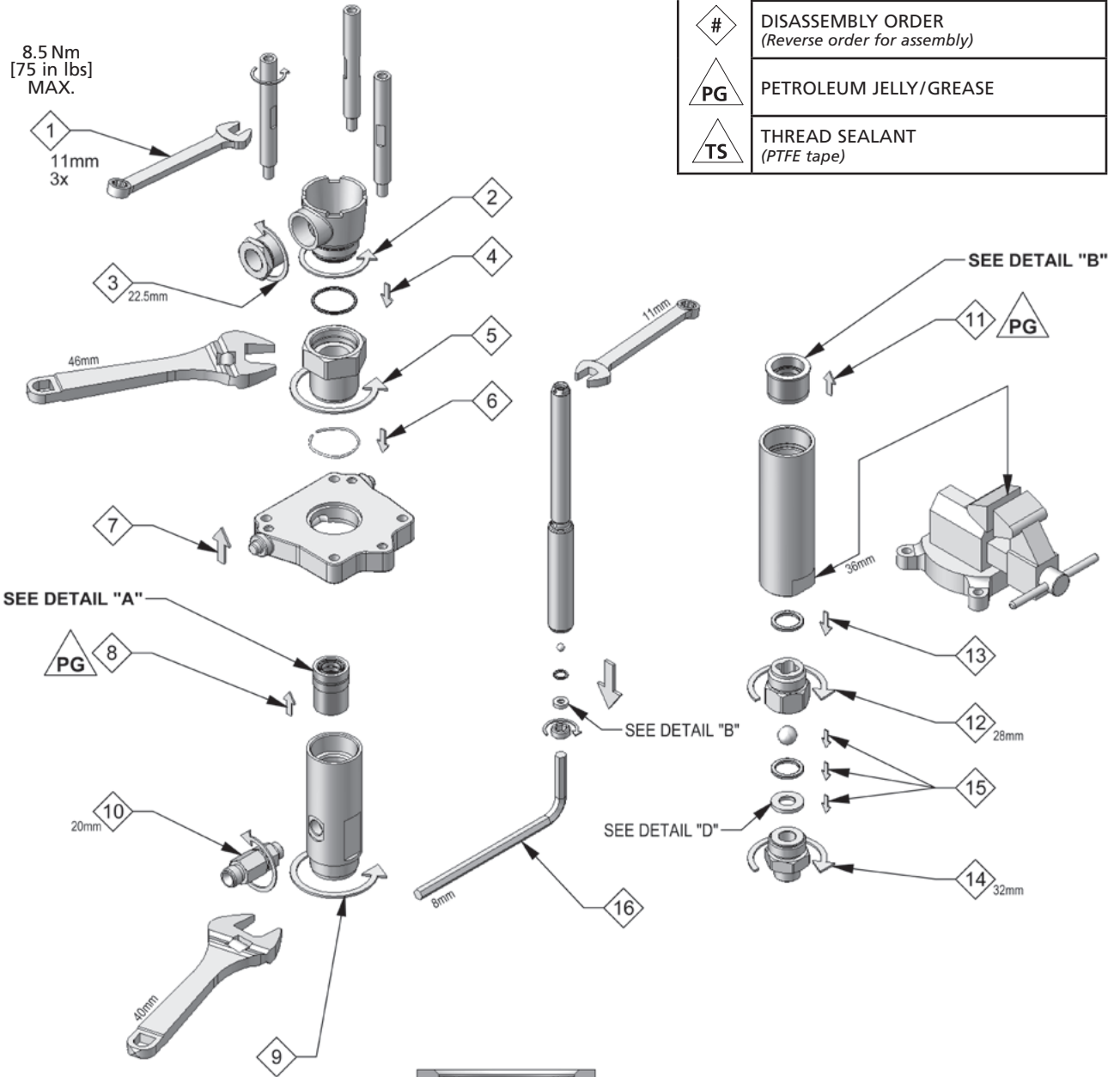

DETAIL "A"

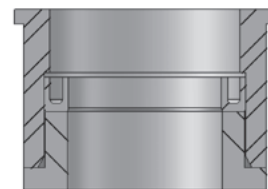

DETAIL "B"

FX4 FLUID PUMP ASSEMBLIES – TROUBLESHOOTING

PROBLEM	CAUSE	SOLUTION
Material in solvent cup	Worn or dirty upper packings.	Replace or clean upper packings as necessary.
Pump does not stop on the down stroke	Worn or dirty lower ball check.	Replace or clean the parts as necessary.
Pump does not stop on the up stroke	Worn or dirty upper ball check. Worn or dirty lower packings.	Replace or clean the parts as necessary.
Pump runs erratically	Blocked material siphon kit. Blocked inlet filter or strainer. Low material level.	Replace or clean the siphon kit. Replace or clean inlet filter or strainer. Replace or refill material container.
Pump runs, with no output	Loose connection in between pump and siphon assembly. Stuck lower ball.	Check that all connections are tight. Replace or clean the parts as necessary.

ACCESSORIES FOR YOUR MX432 BARE PUMP

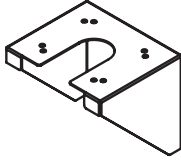

BRACKET
0115-010179

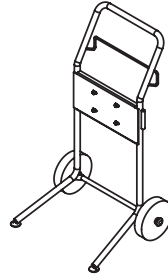

TROLLEY ASSEMBLY
0115-010186
Service Bulletin 77-2915

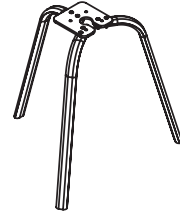

TRIPOD ASSEMBLY
0115-010100
Service Bulletin 77-2915



LUBRICATING OIL FOR
FX4 FLUID PUMP
0114-009433 (Solvent Based Materials)
0114-014871 (Water Based Materials)

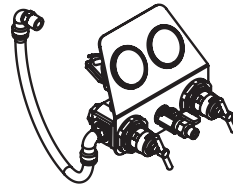

AIR CONTROLS
0115-010180 (Air Assist)
0115-010198 (Airless)
Service Bulletin 77-2915



FLUID FILTER (100 MESH)
0110-009130
Service Bulletin 77-2915

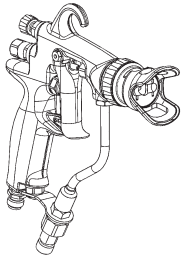

AA4400M AIR ASSIST SPRAY GUN

FLAT TIP VERSIONS:
0909-4400-HF0000
(HVLP, no tip included)
0909-4400-LF0000
(Trans-Tech, no tip included)

TWIST TIP VERSIONS:
0909-4400-HT0000
(HVLP, no tip included)
0909-4400-LT0000
(Trans-Tech, no tip included)

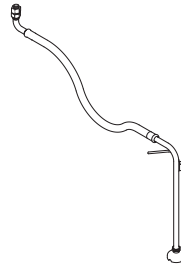

SUCTION HOSE ASSEMBLY

0115-010236 20 L
(20 MESH)
0115-010381 200 L
(30 MESH)
0115-010106 Tripod Inlet Tube
(16 MESH)
Service Bulletin 77-2923

WARRANTY

This product is covered by Binks' 5 Year Limited Warranty.

Binks European Sales and Service Listing: www.itwifeuro.com

ITW Industrial Finishing

Binks has authorized distributors throughout the world. For technical assistance or the distributor nearest you, see listing below.

ITW Industrial Finishing:

Ringwood Road, Bournemouth
BH11 9LH England
Tel: +44(0) 1202 571111 Fax: +44(0) 1202 573488
Email: industrial.mktg@itwfinishing.co.uk

ITW Surfaces et Finitions:

163-171 Av des Auréals
26014 Valence cedex France
Tel: +33 4 75 75 27 00 Fax: +33 4 75 75 27 59
Email: mkt@itwsf.com

ITW Oberflächentechnik GmbH:

Justus-von-Liebig-Straße 31
D-63128 Dietzenbach Germany
Tel: +49 (0) 6074-403-1 Fax: +49 (0) 6074-403-300
Email: marketing@itw-finishing.de



www.itwifeuro.com