



G15/G40

Manual Air-Assisted Spray Guns designed
for exceptional spray quality and ease of use



PROVEN QUALITY. LEADING TECHNOLOGY.

Exceptional Spray Quality



Maximize efficiency and quality, while reducing operator fatigue!

G15/G40 air-assisted guns use the highest quality components for long lasting reliable performance. Most importantly, the G15/G40 guns deliver superior spray performance while improving transfer efficiency and reducing material usage.

G15/G40 guns have been **UPGRADED!**

- AAF tip line is designed for soft spray and improved transfer efficiency
- Longer-lasting needle packing – even with abrasive materials
- More robust air cap retaining ring threads
- All tips have a ring to retain the tip in the air cap
- Easier removal of the integrated gun fluid filter – no threads or tools needed
- G15 air cap indexing offers increased durability

Different Applications Need Different Guns



G15 – 105 bar (1500 psi) models designed for the wood industry and other low and medium pressure applications



G40 – 280 bar (4000 psi) models designed for high pressure industrial applications



G40 RAC – A 280 bar (4000 psi) model designed with a Reverse-A-Clean tip for high pressure applications

G15/G40 Air-Assisted Guns

Spray Quality

Achieve a Superior Finish

- Enhanced tip design creates uniform atomization for a superior finish quality
- Unique air cap enables soft spray
- Lower fluid and air pressure design allows for increased transfer efficiency
- Adjustable fan pattern means less overspray, less material waste, less VOC's, and improved productivity

Ergonomics

Maximize Productivity

- Overall weight and gun balance is better than other spray guns in its category
- Trigger pull force is ultra-light – reducing operator fatigue and muscle stress
- Handle design fits any size hand for increased operator comfort

Cost of Ownership

Save Time and Money

- Ease of assembly and disassembly reduces repair time
- Designed to minimize wear of replacement parts
- Fewer parts means an overall lower cost of repair

Merkur™ Air-Assisted Packages

High Performance Finishing!

Quality pumps enhance any finishing system. Paired with G15/G40 air-assisted spray guns, the Merkur fine finish packages are designed to improve productivity, reduce costs, lower emissions and provide consistent, high quality finishes for all of your demanding applications.

High Quality Finish

Low pulsation output and smooth pump change over deliver a consistent spray pattern.

Easy-to-use

Easy-to-flush design allows for fast colour changes and reduced solvent usage.

Rugged Construction

300 Series stainless steel pump construction provides long-lasting durability.



Designed with the user in mind

Quick, Accurate Positioning!

The G15 indexing air cap provides fast and accurate positioning in either the vertical or horizontal position.



Reduce Overspray and Increase Productivity!

3/4 turn fan pattern adjustment allows the operator to change the spray width according to the size of parts.

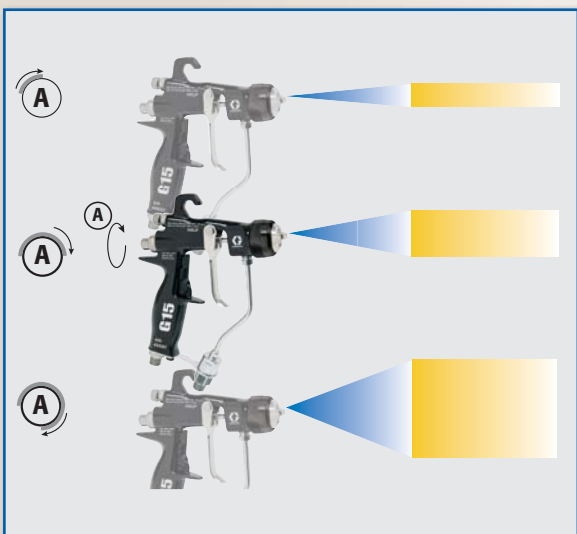

G15/G40 Air-Assisted Gun

1. High strength hook
2. Air cap retain feature
3. Indexing air cap (G15 only)
4. Optimal spray pattern tips
5. Soft spray air cap
6. Quick change needle/seat assembly
7. Ultra-light trigger pull
8. Integrated in-line filter
9. 3/4 turn fan pattern adjustment
10. Lightweight design (450 g)
11. Ergonomic handle
12. Optimal hose connect angles
13. Optional low profile fluid swivel

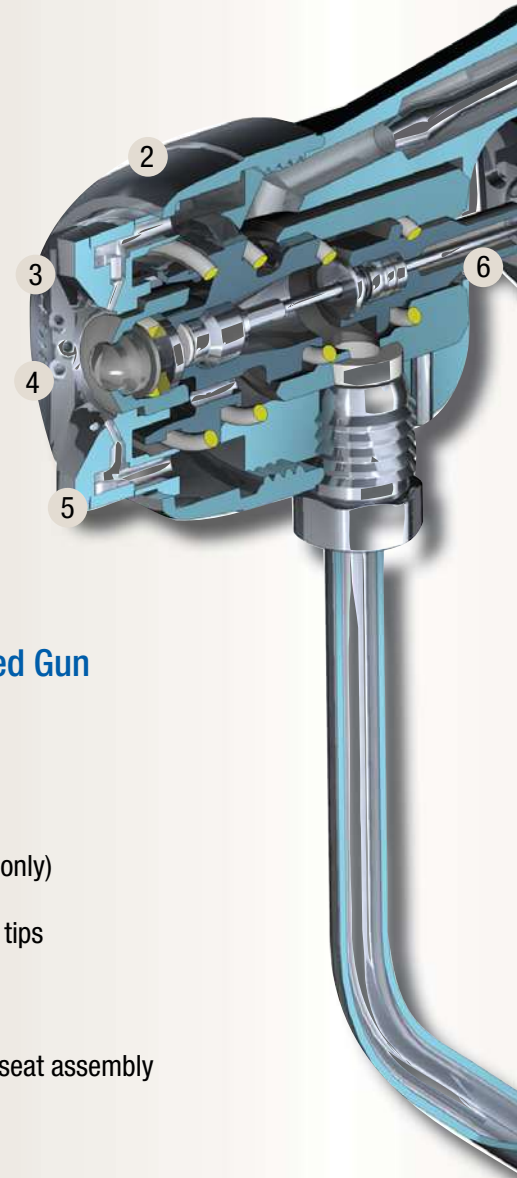



Increase Spray Performance!

Enhanced tip design provides uniform atomization and improved finish quality.



Three air-assisted tip lines to meet the needs of different applications

AAF Tips - Fine finish tips with a pre-orifice for soft spray and increased transfer efficiency

AAM Tips - Fine finish tips for a high quality finish at low and medium pressures

GG4 Tips - High wear tips for industrial finishes at high pressures



All tips have a ring to retain the tip in the air cap.

Ordering Information

Air-Assisted Gun Models Product Information

AIR-ASSISTED GUN MODELS

- **G15 carbide model** is recommended for low to medium viscosity materials
- **G15 acetal seat model** is recommended for acid-catalyzed materials
- **G40 models** are recommended for high viscosity materials above 105 bar (1500 psi)

24C853 G15 Air-Assisted Carbide Gun

Medium pressure gun includes carbide seat/ball, indexing air cap and choice of AAM or AAF spray tip from chart, which is specified when order is placed.

24C854 G15 Air-Assisted Gun

Medium pressure gun includes a plastic seat, indexing air cap and choice of AAM or AAF spray tip from chart, which is specified when order is placed.

24C855 G40 Air-Assisted Gun

High pressure gun includes a carbide seat, tip guard aircap and choice of AAM, AAF or GG4 spray tip from chart, which is specified when order is placed.

24C856 G40 Air-Assisted Hi-Flow Gun

High pressure gun with no restrictions to avoid pressure drop with heavy viscosity materials. Includes a carbide seat, tip guard and a choice of AAM, AAF or GG4 spray tip.

24C857 G40 Air-Assisted Reverse-A-Clean (RAC) Spray Gun

High pressure gun with a RAC spray tip to reduce downtime caused by frequent tip clogging. Includes a carbide seat, tip guard, and a choice of LTX spray tip.



ACCESSORIES

224453 100 Mesh Fluid Filter Kit

100 mesh (.005 gap spacing) replacement fluid filters. Quantity of 5.

238563 60 Mesh Fluid Filter Kit

60 mesh (.009 gap spacing) replacement fluid filters for coarser particle filtering to replace standard 100 mesh filters. Quantity of 3.

241804 Tip Filter Kit

Replacement filters for spray tip orifice sizes 0.007, 0.009, and 0.011. Quantity of 10.

189018 Fluid Swivel Connector

516 bar (51.6 MPa, 7500 psi) maximum working pressure. Connector to ease movement of the gun and fluid hose.

238694 High Pressure Fluid Ball Valve

350 bar (35 MPa, 5000 psi) maximum working pressure. 3/8 npt(mbe). SST wetted parts, PEEK seats, PTFE seals. Compatible with acid-catalyzed materials. Can be used as fluid drain valve.

241812 Fluid Hose

242 bar (24 MPa, 3500 psi) maximum working pressure. 1/4-18 npsm(fbe), 3/16 in (5 mm) ID, 7.62 m (25 ft) long, nylon tubing with polyurethane cover.

249473 Air Fitting and Tubing Kit

Alternative-style connector for air inlet and hose. 3/8 in to 1/4 Push-To-Lock fitting, 7.62 m (25 ft) long, nylon tubing. Optional quick disconnect available.

241811 Air Hose

7 bar (0.7 MPa, 100 psi) maximum working pressure. 1/4-18 npsm(fbe), 6 mm (1/4 in) ID, 7.62 m (25 ft) long polyurethane tubing.

15G093 G15 Gun Flush Box Insert

Insert for use with Gun Flush Box 244105 and G15 Spray Guns.

15G346 G40 Gun Flush Box Insert

Insert for use with Gun Flush Box 244105 and G40 Spray Guns.

249140 HVLP Verification Kit

Use to check air cap air pressure at various air supply air pressures. Do not use for actual spraying.

249598 Unclogging Needle Kit

Kit includes picks for unclogging gun tip.

101892 Gun Brush

Use to clean the gun.

15C161 Ultimate Gun Cleaning Kit

Kit includes brushes and tools for gun maintenance.

24C356 JIC Fluid Fitting

Replaces standard npsm fluid fitting.

289499 Fine Adjust Fan Pattern Knob

Replacement fan valve assemble for fine adjustment accuracy.

TECHNICAL SPECIFICATIONS

Maximum Working Fluid Pressure	Model G15: 105 bar (10 MPa, 1500 psi)
	Model G40: 280 bar (28 MPa, 4000 psi)
Maximum Working Air Pressure	7 bar (0.7 MPa, 100 psi)
Maximum Working Fluid Temperature	43° C (110° F)
Fluid Inlet	1/4-18 npsm*
Air Inlet	1/4-18 npsm (R1/4-19) compound male thread**
Gun Weight450 grams (16 oz)

Sound Pressure at 1.4 bar (140 kPa, 20 psi)	66.9 dB(A)
Gun Body	Forged Aluminum
Fluid Filter	100 mesh
Trigger Pull	3.9 lb
Wetted Parts	Stainless Steel, Carbide, Ultra High Molecular Weight Polyethylene, Acetal, PTFE, nylon
Instruction Manual	3A0149

*Optional swivel fitting available
**Optional quick-disconnect available

Spray Tip Selection Chart

AAM and GG4 Air-Assisted Spray Tip Selection Chart

AAM Tips: Fine Finish Tips recommended for *high finish quality* applications at *low and medium pressures*.

GG4 Tips: High Wear Industrial Tips recommended for *high pressure* applications.

Do not use tips in the grey shaded area of the chart with Model G15 guns (24C853 or 24C854).

All tips in the Spray Tip Selection Chart can be used with Model G40 guns. Use tips in the grey shaded area of the chart with Model G40 guns only.

Order desired tip (part no. AAMxxx or GG4xxx) from matrix below. *xxx = 3 digit number below Maximum Pattern Width.*

(Example: AAM409)

Orifice Size mm (in)	*Fluid Output, fl lpm (oz/min)		Maximum Pattern Width at 300 mm (12 in)								
	at 41 bar (4.1 MPa, 600 psi)	at 70 bar (7.0 MPa, 1000 psi)	100 (2 to 4)	150 (4 to 6)	200 (6 to 8)	250 (8 to 10)	300 (10 to 12)	350 (12 to 14)	400 (14 to 16)	450 (16 to 18)	500 (18 to 20)
† 0.178 (0.007)	0.1 (4.0)	0.15 (5.2)	◆107	207	307						
† 0.229 (0.009)	0.2 (7.0)	0.27 (9.1)	109	209	309	409	509				
† 0.279 (0.011)	0.3 (10.0)	0.4 (13.0)	111	211	311	411	511	611			
0.330 (0.013)	0.4 (13.0)	0.5 (16.9)		213	313	413	513	613	713		
0.381 (0.015)	0.5 (17.0)	0.7 (22.0)		215	315	415	515	615	715	815	
0.432 (0.017)	0.7 (22.0)	0.85 (28.5)		217	317	417	517	617	717	817	917
0.483 (0.019)	0.8 (28.0)	1.09 (36.3)		219	319	419	519	619	719	819	919
0.533 (0.021)	1.0 (35.0)	1.36 (45.4)			321	421	521	621	721	821	921
‡ 0.584 (0.023)	1.2 (40.0)	1.56 (51.9)				423	523	623	723		923
‡ 0.635 (0.025)	1.5 (50.0)	1.94 (64.8)				425		625	725	825	
‡ 0.686 (0.027)	1.7 (58.5)	2.27 (75.8)					527	627		827	
‡ 0.737 (0.029)	1.9 (68.0)	2.65 (88.2)						629			
‡ 0.787 (0.031)	2.2 (78.0)	3.03 (101.1)				431		631			
‡ 0.838 (0.033)	2.5 (88.0)	3.42 (114.1)						633		◆833	
‡ 0.889 (0.035)	2.8 (98.0)	3.81 (127.1)				435					
‡ 0.940 (0.037)	3.1 (108.0)	4.20 (140.0)							737		
‡ 0.991 (0.039)	3.4 (118.0)	4.59 (153.0)					539	639		839	

† These tip sizes include a 150 mesh tip filter
 ◆ GG4 tips only
 ‡ Do not use these tips with Model G15 guns (24C853 and 24C854)

AAF Air-Assisted Fine Finish Pre-Orifice Spray Tip Selection Chart

Fine Finish Tips recommended for *high finish quality* applications at *low and medium pressures*.

AAF tips have a pre-orifice which assists in atomizing shear thinning materials, including waterbornes and lacquers.

Order desired tip (part no. AAFxxx) from matrix below.

Orifice Size mm (in)	*Fluid Output, fl lpm (oz/min)		Maximum Pattern Width at 305 mm (12 in)			
	at 41 bar (4.1 MPa, 600 psi)	at 70 bar (7.0 MPa, 1000 psi)	200 (6 to 8)	250 (8 to 10)	300 (10 to 12)	350 (12 to 14)
0.279 (0.011)	9.5 (0.28)	12.5 (0.37)	310	410	510	610
0.330 (0.013)	12.0 (0.35)	16.0 (0.47)	312	412	512	612
0.381 (0.015)	16.0 (0.47)	21.0 (0.62)		414	514	614
0.432 (0.017)	20.0 (0.59)	26.5 (0.78)		416	516	616



ABOUT GRACO

Founded in 1926, Graco is a world leader in fluid handling systems and components. Graco products move, measure, control, dispense and apply a wide range of fluids and viscous materials used in vehicle lubrication, commercial and industrial settings.

The company's success is based on its unwavering commitment to technical excellence, world-class manufacturing and unparalleled customer service. Working closely with qualified distributors, Graco offers systems, products and technology that set the quality standard in a wide range of fluid handling solutions. Graco provides equipment for spray finishing, protective coating, paint circulation, lubrication, and dispensing sealants and adhesives, along with power application equipment for the contractor industry. Graco's ongoing investment in fluid management and control will continue to provide innovative solutions to a diverse global market.

GRACO LOCATIONS

CONTACT

MAILING ADDRESS
P.O. Box 1441
Minneapolis, MN 55440-1441
Tel: 612.623.6000
Fax: 612.623.6777

AMERICAS

MINNESOTA
Worldwide Headquarters
Graco Inc.
88-11th Avenue N.E.
Minneapolis, MN 55413

EUROPE

BELGIUM
European Headquarters
Graco N.V.
Industrieterrein-Oude Bunders
Slakweidestraat 31
3630 Maasmechelen,
Belgium
Tel: 32.89.770.700
Fax: 32.89.770.777

ASIA PACIFIC

JAPAN
Graco K.K.
1-27-12 Hayabuchi
Tsuzuki-ku
Yokohama City, Japan 2240025
Tel: 81.45.593.7300
Fax: 81.45.593.7301

ASIA PACIFIC

CHINA
Graco Hong Kong Ltd.
Representative Office
Room 118 1st Floor
No.2 Xin Yuan Building
No.509 Cao Bao Road
Shanghai, P.R. China 200233
Tel: 86.21.649.50088
Fax: 86.21.649.50077

ASIA PACIFIC

KOREA
Graco Korea Inc.
Choheung Bank Building
4th Floor #1599
Gwanyang-Dong, Dongan-Ku,
Anyang-Si, Gyunggi-Do,
Korea 431-060
Tel: 82(Korea).31.476.9400
Fax: 82(Korea).31.476.9801

All written and visual data contained in this document are based on the latest product information available at the time of publication.
Graco reserves the right to make changes at any time without notice.

Graco is certified ISO 9001.

Europe
+32 89 770 700
FAX +32 89 770 777
WWW.GRACO.BE