

RS Gun Universal Adapter Kit

3A1226D

EN

For installing the RS™ Gun onto existing hose bundles. For professional use only.

Part 257754

See page 9 for maximum working pressures.



Important Safety Instructions

Read all warnings and instructions in this manual. Save these instructions.

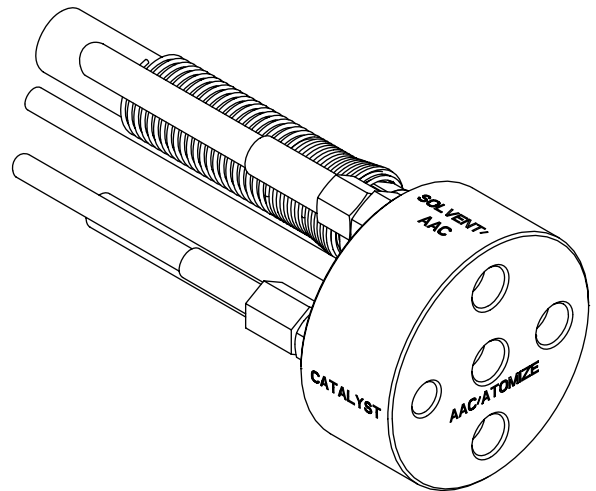

257754_3A0232A_1c

Contents

Related Manuals 2
Warnings 2
Important Two-Component Information 5
Important Methyl Ethyl Ketone Peroxide (MEKP) Safety Information 6
Field Install 7
Parts 8
Replacement Fittings Chart 9
Technical Data 9
Graco Standard Warranty 10



Related Manuals









Manuals are available at www.graco.com. Manuals are in English.

Part	Description
3A0232	RS Gun manual

Warnings

The following warnings are for the setup, use, grounding, maintenance, and repair of this equipment. The exclamation point symbol alerts you to a general warning and the hazard symbols refer to procedure-specific risks. When these symbols appear in the body of this manual, refer back to these Warnings. Product-specific hazard symbols and warnings not covered in this section may appear throughout the body of this manual where applicable.

 WARNING	
	<p>FIRE AND EXPLOSION HAZARD</p> <p>Flammable fumes, such as solvent and paint fumes, in work area can ignite or explode. To help prevent fire and explosion:</p> <ul style="list-style-type: none"> • Use equipment only in well ventilated area. • Eliminate all ignition sources; such as pilot lights, cigarettes, portable electric lamps, and plastic drop cloths (potential static arc). • Keep work area free of debris, including solvent, rags and gasoline. • Do not plug or unplug power cords, or turn power or light switches on or off when flammable fumes are present. • Ground all equipment in the work area. See Grounding instructions. • Use only grounded hoses. • Hold gun firmly to side of grounded pail when triggering into pail. • If there is static sparking or you feel a shock, stop operation immediately. Do not use equipment until you identify and correct the problem. • Keep a working fire extinguisher in the work area.

 WARNING	
  	<p>SKIN INJECTION HAZARD</p> <p>High-pressure fluid from dispensing device, hose leaks, or ruptured components will pierce skin. This may look like just a cut, but it is a serious injury that can result in amputation. Get immediate surgical treatment.</p> <ul style="list-style-type: none"> • Engage trigger lock when not dispensing. • Do not point dispensing device at anyone or at any part of the body. • Do not put your hand over the fluid outlet. • Do not stop or deflect leaks with your hand, body, glove, or rag. • Follow the Pressure Relief Procedure when you stop dispensing and before cleaning, checking, or servicing equipment. • Tighten all fluid connections before operating the equipment. • Check hoses and couplings daily. Replace worn or damaged parts immediately.
 	<p>MOVING PARTS HAZARD</p> <p>Moving parts can pinch, cut or amputate fingers and other body parts.</p> <ul style="list-style-type: none"> • Keep clear of moving parts. • Do not operate equipment with protective guards or covers removed. • Pressurized equipment can start without warning. Before checking, moving, or servicing equipment, follow the Pressure Relief Procedure and disconnect all power sources.
	<p>TOXIC FLUID OR FUMES HAZARD</p> <p>Toxic fluids or fumes can cause serious injury or death if splashed in the eyes or on skin, inhaled, or swallowed.</p> <ul style="list-style-type: none"> • Read MSDSs to know the specific hazards of the fluids you are using. • Store hazardous fluid in approved containers, and dispose of it according to applicable guidelines. • Always wear chemically impermeable gloves when spraying, dispensing, or cleaning equipment.
	<p>PERSONAL PROTECTIVE EQUIPMENT</p> <p>You must wear appropriate protective equipment when operating, servicing, or when in the operating area of the equipment to help protect you from serious injury, including eye injury, hearing loss, inhalation of toxic fumes, and burns. This equipment includes but is not limited to:</p> <ul style="list-style-type: none"> • Protective eyewear, and hearing protection. • Respirators, protective clothing, and gloves as recommended by the fluid and solvent manufacturer.

WARNING
**EQUIPMENT MISUSE HAZARD**

Misuse can cause death or serious injury.

- Do not operate the unit when fatigued or under the influence of drugs or alcohol.
- Do not exceed the maximum working pressure or temperature rating of the lowest rated system component. See **Technical Data** in all equipment manuals.
- Use fluids and solvents that are compatible with equipment wetted parts. See **Technical Data** in all equipment manuals. Read fluid and solvent manufacturer's warnings. For complete information about your material, request MSDS from distributor or retailer.
- Do not leave the work area while equipment is energized or under pressure. Turn off all equipment and follow the **Pressure Relief Procedure** when equipment is not in use.
- Check equipment daily. Repair or replace worn or damaged parts immediately with genuine manufacturer's replacement parts only.
- Do not alter or modify equipment.
- Use equipment only for its intended purpose. Call your distributor for information.
- Route hoses and cables away from traffic areas, sharp edges, moving parts, and hot surfaces.
- Do not kink or over bend hoses or use hoses to pull equipment.
- Keep children and animals away from work area.
- Comply with all applicable safety regulations.



**PRESSURIZED ALUMINUM PARTS HAZARD**

Use of fluids that are incompatible with aluminum in pressurized equipment can cause serious chemical reaction and equipment rupture. Failure to follow this warning can result in death, serious injury, or property damage.



- Do not use 1,1,1-trichloroethane, methylene chloride, other halogenated hydrocarbon solvents or fluids containing such solvents.
- Many other fluids may contain chemicals that can react with aluminum. Contact your material supplier for compatibility.

Important Two-Component Information

Material Self-ignition

						
<p>Some materials may become self-igniting if applied too thickly. Read material manufacturer's warnings and material MSDS.</p>						

Keep Components A and B Separate

						
<p>Cross-contamination can result in cured material in fluid lines which could cause serious injury or damage equipment. To prevent cross-contamination of the equipment's wetted parts, never interchange component A (catalyst) and component B (resin) parts.</p>						

Changing Materials

- When changing materials, flush the equipment multiple times to ensure it is thoroughly clean.
- Always clean the fluid inlet strainers after flushing.
- Check with your material manufacturer for chemical compatibility.

Important Methyl Ethyl Ketone Peroxide (MEKP) Safety Information

MEKP is among the more hazardous materials found in commercial channels. Proper handling of the “unstable (reactive)” chemicals presents a definite challenge to the plastics industry. The highly reactive property which makes MEKP valuable to the plastics industry in producing the curing reaction of polyester resins and gel-coats also produces the hazards which require great care and caution in its storage, transportation, handling, processing and disposal.

Workers must be thoroughly informed of the hazards that may result from improper handling of MEKP, especially in regards to contamination and heat. They must be thoroughly instructed regarding the proper action to be taken in the storage, use and disposal of MEKP and other hazardous materials used in the laminating operation.



MEKP is flammable and potentially explosive, as well as potentially damaging to the eyes and skin. Read material manufacturer’s warnings and material MSDS to know specific hazards and precautions related to MEKP.

Contaminated MEKP can become explosive. Prevent contamination of MEKP with other materials, which includes, but is not limited to polyester overspray, polymerization accelerators and promoters, and non-stainless metals. Even small amounts of contaminants can make MEKP explosive. This reaction may start slowly, and gradually build-up heat, which can accelerate until fire or an explosion result. This process can take from seconds to days.

Heat applied to MEKP, or heat build-up from contamination reactions can cause it to reach what is called its Self-Accelerating Decomposition Temperature (SADT), which can cause fire or explosion. Spills should be promptly removed, so no residues remain. Spillage can heat up to the point of self-ignition. Dispose in accordance with manufacture’s recommendation.

Store MEKP in a cool, dry and well-ventilated area in the original containers away from direct sunlight and away from other chemicals. It is strongly recommended that the storage temperature remain below 86° F (30° C). Heat will increase the potential for explosive decomposition. Refer to NFPA 432. Keep MEKP away from heat, sparks and open flames.

Current catalysts are premixed and do not require any diluents. Graco strongly recommends that diluents not be used. Diluents add to the possibility of contaminants entering the catalyst system. Never dilute MEKP with acetone or any solvent since this can produce an extremely shock-sensitive compound which can explode.

Use only original equipment or equivalent parts from Graco in the catalyst system (i.e.: hoses, fittings, etc.) because a hazardous chemical reaction may result between substituted parts and MEKP.

To prevent contact with MEKP, appropriate personal protective equipment, including chemically impermeable gloves, boots, aprons and goggles are required for everyone in the work area.

Polyester Resins and Gel-Coats



Spraying materials containing polyester resin and gel-coats creates potentially harmful mist, vapors and atomized particulates. Prevent inhalation by providing sufficient ventilation and the use of respirators in the work area.

Read the material manufacturer’s warnings and material MSDS to know specific hazards and precautions related to polyester resins and gel-coats.

To prevent contact with polyester resins and gel-coats, appropriate personal protective equipment, including chemically impermeable gloves, boots, aprons and goggles are required for everyone in the work area.

Spraying and Lamination Operations



Remove all accumulations of overspray, FRP sandings, etc. from the building as they occur. If this waste is allowed to build up, spillage of catalyst is more likely to start a fire.

If cleaning solvents are required, read material manufacture’s warnings and material MSDS to know specific hazards and precautions. (Graco recommends that clean-up solvents be nonflammable.)

NOTE: Graco recommends that you consult OSHA Sections 1910.94, 1910.106, 1910.107 and NFPA No. 33, Chapter 16,17, and NFPA No. 91 for further guidance.

Field Install



1. Perform proportioner shutdown and pressure relief procedures. See proportioner manual.
2. Attach recommended fittings to the manifold block (7). See **Replacement Fittings Chart** on this page and **Parts** on page 8.
3. Attach existing hoses found on proportioner to recently installed new fittings on the manifold block.
4. Attach hoses included in this kit to RS gun.

NOTE: If a higher flow rate is required, remove swivel fitting found on RS gun and replace with swivel (16) included in this kit.

Parts

RS Gun Field Install Kit 257754

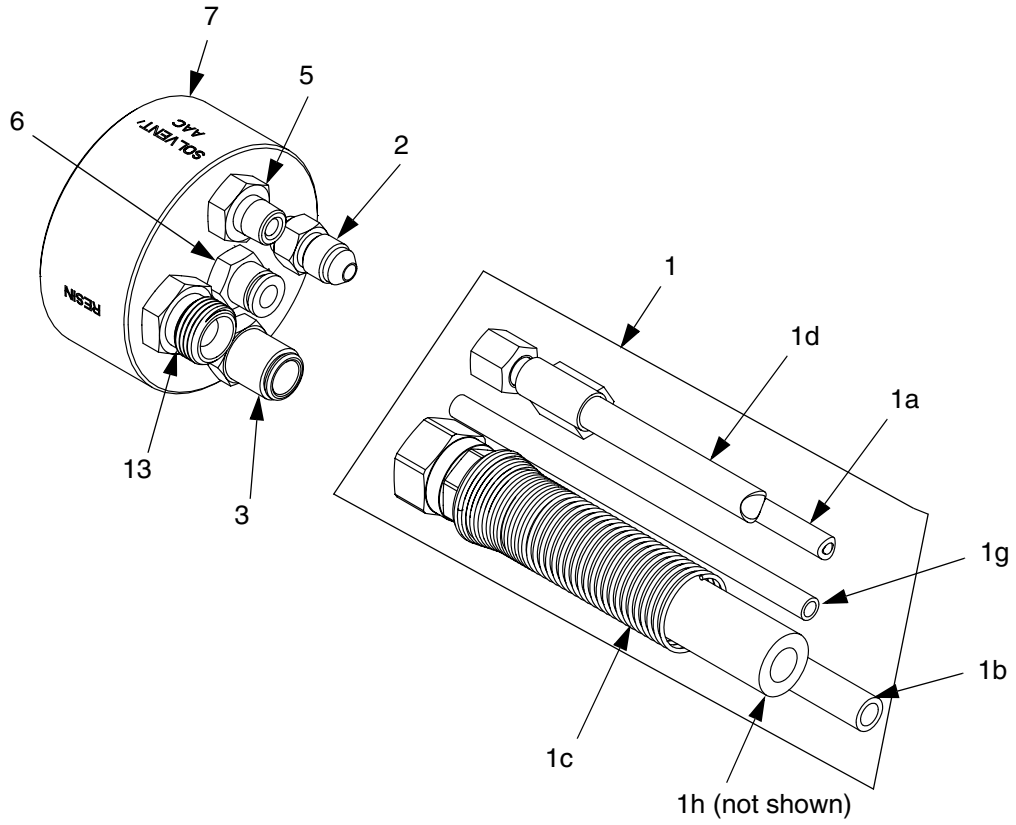

257754_3A0232A_2d

CATALYST (STAINLESS STEEL)

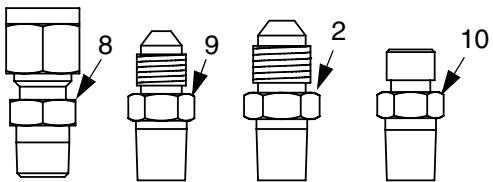

SOLVENT / AAC

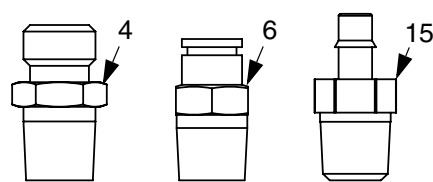

AAC / ATOMIZATION

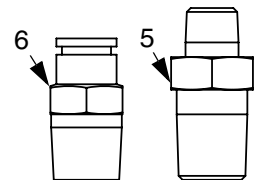

CHOPPER AIR

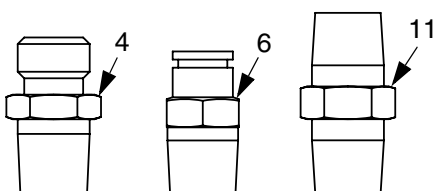

RESIN

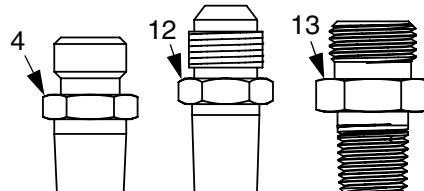

Ref Part	Description	Qty	Ref Part	Description	Qty
1	257766 HOSE BUNDLE	1	5	151519 FITTING, nipple, reducing	2
1a	257771 HOSE, catalyst, 1/8 in. npsm, 3000 psi, 7 ft.	1	6	113034 FITTING, tube	4
1b	520563 TUBE, 3/8 OD x 0.062 wall	7	7	16E818 BLOCK, manifold, aluminum	1
1c	24F533 HOSE, resin, 3/8 in. x 81 in.	1	8	122845 FITTING, 1/4 in. tube coupling x 1/8 nptm	1
1d	257774 HOSE, coupled, 1/4 in., nylon, 7 ft	1	9	122846 FITTING, 3/8-24 JIC(03)M x 1/8 nptm	1
1e	261659 JACKET, scuff, 3 ft. (not shown)	1	10	16E825 FITTING, nipple, 1/8 nptm x 1/8 npsm	1
1g	054130 TUBE, polyethylene, 0.250 OD	7	11	156971 FITTING, nipple, short	1
1h	118758 FITTING, adapter (not shown)	1	12	123597 ADAPTER, 3/8 JIC x 1/4 npt	1
2	124803 ADAPTER, JIC 04 x 1/8 npt, male/male, 316 sst, 6k	2	13	196176 ADAPTER, nipple	2
3	123737 FITTING, tube, push connector	1	15	120707 FITTING, barbed	1
4	162453 FITTING, 1/4 npsm x 1/4 npt	3	16	24F603 SWIVEL, 1/4 npsm x 3/8 npsm	1
				--- <i>Not sold separately.</i>	

Replacement Fittings Chart

If you wish to replace an existing gun with the RS gun, install the following fittings on the respective connection. See **Parts** on page 8 for fitting reference numbers.

Connection	Previous Gun Type and Reference Number				
	INDy	Formula	MVP Pro Series	ATG/ATC	Cipher/ Duramax/ EMG
Catalyst	8	8	2 or 9	10	9
Chopper Air	4 or 6	4 or 6	11	11	4
Resin	4	4	4 or 12	4 or 12	---
Solvent/AAC™	4 or 6	4 or 6	15	---	15
AAC/Atomizing	6	6	---	5	---

NOTE: If the fittings in the kit will not work with your application, the following ports are found on the manifold: (4) 1/4-18 npt, (1) 1/8-27 npt.

Technical Data

Maximum Working Pressure	Resin: 3300 psi (23 MPa, 228 bar) Catalyst: 3000 psi (21 MPa, 207 bar) Solvent: 225 psi (1.6 MPa, 155 bar) Air: 125 psi (0.9 MPa, 86 bar)
Wetted Parts	PTFE, stainless steel, zinc-plated carbon steel, nylon, brass, aluminum

Graco Standard Warranty

Graco warrants all equipment referenced in this document which is manufactured by Graco and bearing its name to be free from defects in material and workmanship on the date of sale to the original purchaser for use. With the exception of any special, extended, or limited warranty published by Graco, Graco will, for a period of twelve months from the date of sale, repair or replace any part of the equipment determined by Graco to be defective. This warranty applies only when the equipment is installed, operated and maintained in accordance with Graco's written recommendations.

This warranty does not cover, and Graco shall not be liable for general wear and tear, or any malfunction, damage or wear caused by faulty installation, misapplication, abrasion, corrosion, inadequate or improper maintenance, negligence, accident, tampering, or substitution of non-Graco component parts. Nor shall Graco be liable for malfunction, damage or wear caused by the incompatibility of Graco equipment with structures, accessories, equipment or materials not supplied by Graco, or the improper design, manufacture, installation, operation or maintenance of structures, accessories, equipment or materials not supplied by Graco.

This warranty is conditioned upon the prepaid return of the equipment claimed to be defective to an authorized Graco distributor for verification of the claimed defect. If the claimed defect is verified, Graco will repair or replace free of charge any defective parts. The equipment will be returned to the original purchaser transportation prepaid. If inspection of the equipment does not disclose any defect in material or workmanship, repairs will be made at a reasonable charge, which charges may include the costs of parts, labor, and transportation.

THIS WARRANTY IS EXCLUSIVE, AND IS IN LIEU OF ANY OTHER WARRANTIES, EXPRESS OR IMPLIED, INCLUDING BUT NOT LIMITED TO WARRANTY OF MERCHANTABILITY OR WARRANTY OF FITNESS FOR A PARTICULAR PURPOSE.

Graco's sole obligation and buyer's sole remedy for any breach of warranty shall be as set forth above. The buyer agrees that no other remedy (including, but not limited to, incidental or consequential damages for lost profits, lost sales, injury to person or property, or any other incidental or consequential loss) shall be available. Any action for breach of warranty must be brought within two (2) years of the date of sale.

GRACO MAKES NO WARRANTY, AND DISCLAIMS ALL IMPLIED WARRANTIES OF MERCHANTABILITY AND FITNESS FOR A PARTICULAR PURPOSE, IN CONNECTION WITH ACCESSORIES, EQUIPMENT, MATERIALS OR COMPONENTS SOLD BUT NOT MANUFACTURED BY GRACO. These items sold, but not manufactured by Graco (such as electric motors, switches, hose, etc.), are subject to the warranty, if any, of their manufacturer. Graco will provide purchaser with reasonable assistance in making any claim for breach of these warranties.

In no event will Graco be liable for indirect, incidental, special or consequential damages resulting from Graco supplying equipment hereunder, or the furnishing, performance, or use of any products or other goods sold hereto, whether due to a breach of contract, breach of warranty, the negligence of Graco, or otherwise.

FOR GRACO CANADA CUSTOMERS

The Parties acknowledge that they have required that the present document, as well as all documents, notices and legal proceedings entered into, given or instituted pursuant hereto or relating directly or indirectly hereto, be drawn up in English. Les parties reconnaissent avoir convenu que la rédaction du présente document sera en Anglais, ainsi que tous documents, avis et procédures judiciaires exécutés, donnés ou intentés, à la suite de ou en rapport, directement ou indirectement, avec les procédures concernées.

Graco Information

For the latest information about Graco products, visit www.graco.com.

TO PLACE AN ORDER, contact your Graco distributor or call to identify the nearest distributor.

Phone: 612-623-6921 **or Toll Free:** 1-800-328-0211 **Fax:** 612-378-3505

*All written and visual data contained in this document reflects the latest product information available at the time of publication.
Graco reserves the right to make changes at any time without notice.*

Original instructions. This manual contains English. MM 3A1226

Graco Headquarters: Minneapolis

International Offices: Belgium, China, Japan, Korea

GRACO INC. AND SUBSIDIARIES • P.O. BOX 1441 • MINNEAPOLIS MN 55440-1441 • USA

Copyright 2010, Graco Inc. All Graco manufacturing locations are registered to ISO 9001.

www.graco.com
Revised 10/2011