

Automatic G40 Air-Assisted Spray Guns

311052H

EN

For air-assisted spraying of paints and coatings. For professional use only.

Approved for use in European explosive atmosphere locations.

4000 psi (28 MPa, 280 bar) Maximum Working Fluid Pressure

100 psi (0.7 MPa, 7 bar) Maximum Working Air Pressure

See page 3 for model information.



Important Safety Instructions

Read all warnings and instructions in this manual.
Save these instructions.

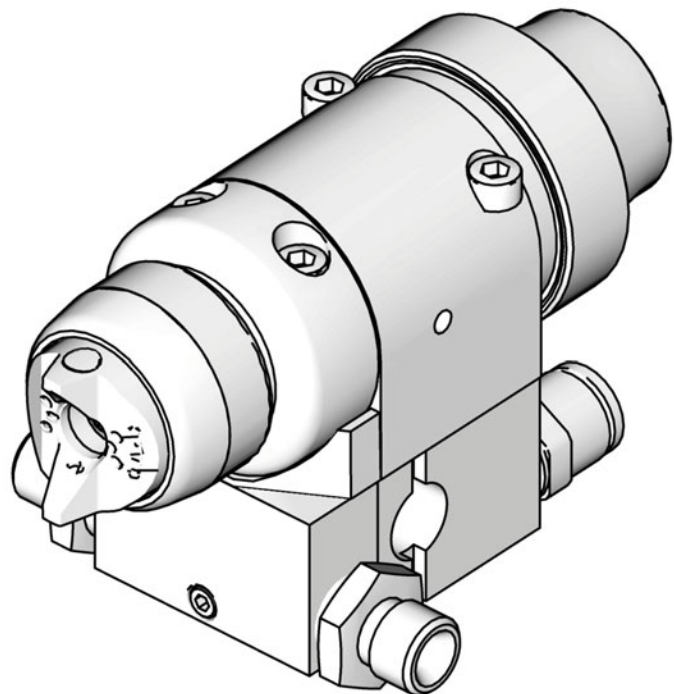

Part No. 288046 Spray Gun shown
mounted on Part No. 288217 Manifold

T18087b



II 2 G c T6

Contents

Models	3	Maintenance	14
Warnings	4	Daily Gun Care	14
Installation	6	General System Maintenance	15
Ventilate Spray Booth	6	Flushing and Cleaning	15
Configure Gun and Manifold	6	Troubleshooting	17
Install Air Fittings	7	General Troubleshooting	17
Ground System	7	Spray Pattern Troubleshooting	19
Mount Gun	8	Service	20
Connect Air Line	9	Disassembly	20
Connect Fluid Line	10	Diffuser Seat Replacement	23
Setup	11	Reassembly	23
Flush Spray Gun	11	Parts	24
Select a Spray Tip and Air Cap	11	Notes	30
Install a Spray Tip	11	AAP Series Tip and Air Cap Selection Charts . . .	31
Position the Air Cap	11	LTX Series RAC Tip Selection Charts	32
Air Cap Alignment Pin	11	RAC Switch Tips	33
Operation	12	Accessories	34
Pressure Relief Procedure	12	Dimensions	36
Adjust Spray Pattern	12	Mounting Hole Layout	37
Apply Fluid	13	Mounting Hole Layout	38
		Technical Data	39
		Graco Standard Warranty	40
		Graco Information	40

Models

 A manifold is required for each gun to be installed.
Refer to the **Parts** section for manifold information.

G40 Standard Spray Gun, 288046, Series B

- High pressure spray gun with Carbide ball and Carbide seat.
- Includes AAP series tip of choice.

G40 Standard Spray Gun, 24F835, Series B

- Air cap optimized for lacquer material.
- High pressure spray gun with Carbide ball and Carbide seat.
- Includes AAP series tip of choice.

G40 Plastic Seat Spray Gun, 288044, Series B







- Medium pressure spray gun with SST ball and plastic seat; for acid catalyzed or thin fluids.
- Best results when used with non-abrasive fluids at pressures below 1500 psi (10.5 MPa, 105 bar).
- Includes AAP series tip of choice.

G40 RAC Spray Gun, 288053, Series A

- High pressure spray gun with AA Reverse-A-Clean (RAC) assembly; and Carbide ball and Carbide Seat.
- Includes LTX Series RAC tip of choice.

Warnings

The following warnings are for the setup, use, grounding, maintenance, and repair of this equipment. The exclamation point symbol alerts you to a general warning and the hazard symbol refers to procedure-specific risk. Refer back to these warnings. Additional, product-specific warnings may be found throughout the body of this manual where applicable.

 WARNING	
	<p>EQUIPMENT MISUSE HAZARD</p> <p>Misuse can cause death or serious injury.</p> <ul style="list-style-type: none"> • Do not operate the unit when fatigued or under the influence of drugs or alcohol. • Do not exceed the maximum working pressure or temperature rating of the lowest rated system component. See Technical Data in all equipment manuals. • Use fluids and solvents that are compatible with equipment wetted parts. See Technical Data in all equipment manuals. Read fluid and solvent manufacturer's warnings. For complete information about your material, request MSDS forms from distributor or retailer. • Check equipment daily. Repair or replace worn or damaged parts immediately with genuine manufacturer's replacement parts only. • Do not alter or modify equipment. • Use equipment only for its intended purpose. Call your distributor for information. • Route hoses and cables away from traffic areas, sharp edges, moving parts, and hot surfaces. • Do not kink or over bend hoses or use hoses to pull equipment. • Keep children and animals away from work area. • Comply with all applicable safety regulations.
 	<p>SKIN INJECTION HAZARD</p> <p>High-pressure fluid from gun, hose leaks, or ruptured components will pierce skin. This may look like just a cut, but it is a serious injury that can result in amputation. Get immediate surgical treatment.</p> <ul style="list-style-type: none"> • Do not point gun at anyone or at any part of the body. • Do not put your hand over the spray tip. • Do not stop or deflect leaks with your hand, body, glove, or rag. • Follow Pressure Relief Procedure in this manual, when you stop spraying and before cleaning, checking, or servicing equipment.
  	<p>FIRE AND EXPLOSION HAZARD</p> <p>Flammable fumes, such as solvent and paint fumes, in work area can ignite or explode. To help prevent fire and explosion:</p> <ul style="list-style-type: none"> • Use equipment only in well ventilated area. • Eliminate all ignition sources; such as pilot lights, cigarettes, portable electric lamps, and plastic drop cloths (potential static arc). • Keep work area free of debris, including solvent, rags and gasoline. • Do not plug or unplug power cords, or turn power or light switches on or off when flammable fumes are present. • Ground all equipment in the work area. See Grounding instructions. • Use only grounded hoses. • Hold gun firmly to side of grounded pail when triggering into pail. • If there is static sparking or you feel a shock, stop operation immediately. Do not use equipment until you identify and correct the problem. • Keep a working fire extinguisher in the work area.

WARNING
**PRESSURIZED EQUIPMENT HAZARD**

Fluid from the gun/dispense valve, leaks, or ruptured components can splash in the eyes or on skin and cause serious injury.

- Follow **Pressure Relief Procedure** in this manual, when you stop spraying and before cleaning, checking, or servicing equipment.
- Tighten all fluid connections before operating the equipment.
- Check hoses, tubes, and couplings daily. Replace worn or damaged parts immediately.

**TOXIC FLUID OR FUMES HAZARD**

Toxic fluids or fumes can cause serious injury or death if splashed in the eyes or on skin, inhaled, or swallowed.

- Read MSDS's to know the specific hazards of the fluids you are using.
- Store hazardous fluid in approved containers, and dispose of it according to applicable guidelines.

**PERSONAL PROTECTIVE EQUIPMENT**

You must wear appropriate protective equipment when operating, servicing, or when in the operating area of the equipment to help protect you from serious injury, including eye injury, inhalation of toxic fumes, burns, and hearing loss. This equipment includes but is not limited to:

- Protective eyewear
- Clothing and respirator as recommended by the fluid and solvent manufacturer
- Gloves
- Hearing protection

Installation

Ventilate Spray Booth



 Check and follow all National, State, and Local codes regarding air exhaust velocity requirements.

Check and follow all local safety and fire codes.

Configure Gun and Manifold



The gun is supplied with an internal fluid plug and seals (5, 6, 7). To use the gun in a circulating system, remove the internal plug. In a non-circulating system, leave the plug in place to minimize flush time.

Circulating System

1. Apply anti-seize lubricant 222955 to the threads and mating faces of the manifold (101) and the elbows (107), supplied unassembled.
2. Install the elbows (107) in both fluid ports of the manifold (101).
3. Connect the fluid supply line to one elbow and the fluid return line to the other. The manifold fluid ports are reversible.
4. Install the gun on the manifold, using the four screws (17). Start the threads of all four screws, and tighten the front two screws first, and then tighten the back two screws to 65 in-lb (7.3 N•m).

Non-circulating System

1. See FIG. 1. Apply anti-seize lubricant 222955 to the threads and mating faces of the manifold (101), plug (109), and elbow (107), supplied unassembled.
2. Install an elbow (107) in one fluid port of the manifold (101), and a plug (109) in the other port.
3. Install the internal plug (5) in the gun fluid port on the same side as the manifold plug.
4. Connect the fluid supply line to the manifold elbow (107).
5. Install the gun on the manifold, using the four screws (17). Start the threads of all four screws, and tighten the front two screws first, and then tighten the back two screws to 65 in-lb (7.3 N•m).

-  Remove when used in circulating systems.
-  Replace with a reducing nipple (107) when used in circulating systems.
-  Install optional filter in fluid inlet port. See **Accessories**, page 34.

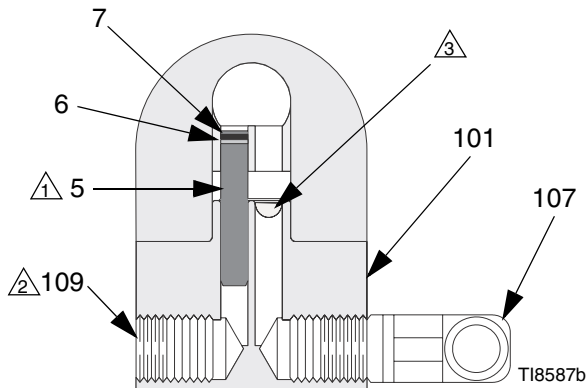

FIG. 1: Non-Circulating Setup Shown (cutaway view)

Install Air Fittings

1. Install the supplied 1/4 in. tube fitting into the cylinder (CYL) air port.
2. Install 3/8 in. tube fittings into the atomization (ATOM) air port and the fan (FAN) air port.

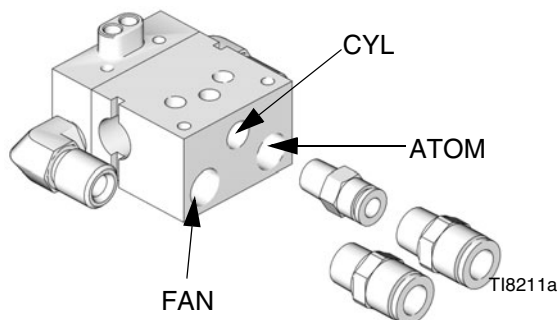
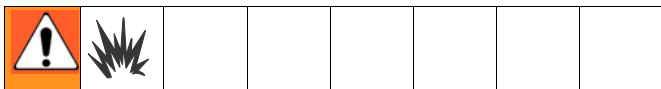

FIG. 2: Air Fittings

Ground System



The following grounding instructions are minimum requirements for a system. Your system may include other equipment or objects that must be grounded. Check your local electrical code for detailed grounding instructions for your area and type of equipment. Your system must be connected to a true earth ground.

Ground Pump

Ground the pump by connecting a ground wire and clamp between the fluid supply and a true earth ground as instructed in your separate pump instruction manual.

Ground Air Compressors and Hydraulic Power Supplies

Ground air compressors and hydraulic power supplies according to the manufacturer recommendations.

Ground Air, Fluid, and Hydraulic Hoses Connected To Pump

Use only electrically conductive hoses with a maximum of 100 ft (30.5 m) combined hose length to ensure grounding continuity. Check the electrical resistance of your air and fluid hoses at least once a week. If the total resistance to ground exceeds 25 megohms, replace the hose immediately.

 Use a meter that is capable of measuring resistance at this level.

Ground Spray Gun

Ground the spray gun by mounting it to a grounded reciprocator and by connecting it to a properly grounded fluid hose and pump.

Ground Fluid Supply Container

Ground the fluid supply container according to local code.

Ground Object Being Sprayed

Ground the object that is being sprayed according to local code.

Ground Solvent Pails

Ground all solvent pails that are used when flushing according to local code. Use only metal pails, which are conductive. Do not place the pail on a non-conductive surface, such as paper or cardboard, which interrupts the grounding continuity.

Mount Gun

Reciprocating Arm Rod Mount

To mount the gun on a reciprocating arm rod [0.5 in. (13 mm) diameter maximum]:

1. Insert the mounting bar (A) through the hole in the manifold as shown in FIG. 3.

 Use the 1/8 in. alignment pin (P) to assist in orienting the gun.

2. Secure the gun to the bar by tightening the mounting screw (B).

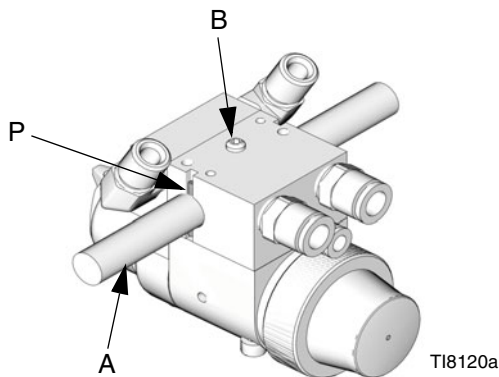

FIG. 3: Reciprocating Arm Mount

Stationary Support

To mount the gun on a stationary support (refer to FIG. 4. and to **Mounting Hole Layout**, page 37):

1. Align the manifold with the alignment pins. Locate alignment pins and holes per the **Mounting Hole Layout** illustration, page 37.

2. Secure the gun to the support with two M5 x 0.8 capscrews (S). The screws must be long enough to engage the threaded holes in the gun manifold to a depth of 1/4 in. (6 mm).

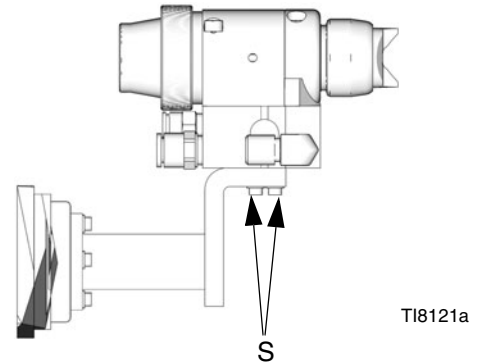

FIG. 4: Stationary Support Mount

Retrofit Adapter Plate

The retrofit adapter plate enables the manifold to be attached to a variety of bolt patterns.

To mount the gun using the retrofit adapter plate (kit 288197):

1. Mount adapter plate to manifold using the three screws provided with the kit (FIG. 5).
2. Bolt plate to mounting surface using four M5 x 0.8 capscrews. Refer to the **Mounting Hole Layout**, page 37.

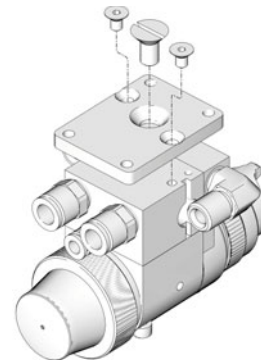



FIG. 5: Retrofit Adapter Plate

Connect Air Line

1. Install an air/water separator and an air line filter to ensure a clean, dry air supply to the gun. Dirt and moisture in the line can ruin the appearance of your finished piece.
2. Install an air pressure regulator on each gun air supply line.
3. For manifolds with separate fan and atomization ports, the gun cylinder, fan, and atomization air must be supplied and regulated separately. For manual valve manifolds, only one supply line is required for both atomization and fan air.

 A minimum of 50 psi (0.34 MPa, 3.4 bar) air pressure must be supplied to the cylinder for proper operation. Set the atomization air as needed for complete atomization of the entire pattern. The tip size is the primary controller of the pattern size. Use the fan air only as needed to slightly adjust the pattern size.

4. Install a bleed-type master air shutoff valve on the main air line. Install an additional bleed-type valve on each pump air supply line, downstream of the pump air regulator, to relieve air trapped between this valve and the pump after the air regulator is shut off.



The bleed-type air shutoff valve is required in your system to relieve air trapped between this valve and the pump after the air regulator is closed. Trapped air can cause the pump to cycle unexpectedly, which could result in serious injury.

5. Install a bleed-type air shutoff valve on each gun air supply line, downstream of the gun air regulator, to shut off air to the gun.
6. For manifolds with separate fan and atomization ports, connect a separate air supply line to the gun atomizing air inlet (D) and cylinder air inlet (C). Connect an air supply line to the fan air inlet (E) if desired. See FIG. 6. For manifolds with a manual fan valve, only one supply line is required for both atomization and fan air.

 The gun atomizing and fan air inlets are 3/8 in. (9.5 mm) O.D. tubing compatible. The cylinder air inlet accepts 1/4 in. (6.3 mm) O.D. tubing.

Connect Fluid Line

 Before connecting the fluid line, blow it out with air and flush it with solvent. Use solvent that is compatible with the fluid to be sprayed.

A fluid drain valve(s) is required in your system to assist in relieving fluid pressure in the displacement pump, hose and gun; triggering the gun to relieve pressure may not be sufficient.

A fluid pressure regulator must be installed in the system if the pump's maximum working pressure exceeds the gun's maximum fluid working pressure (see the front cover).

1. Install a fluid filter and drain valve(s) close to the pump's fluid outlet.
2. Install a fluid pressure regulator to control fluid pressure to the gun.

 Some applications require fine-tuned control of fluid pressure. You can control fluid pressure more accurately with a fluid pressure regulator than by regulating the air pressure to the pump.

3. Install a fluid shutoff valve to shut off the fluid supply to the gun.
4. Install an in-line fluid filter on the gun fluid inlet (F) to avoid clogging the spray tip with particles from the fluid. See FIG. 6.
5. **In a circulating system**, connect a grounded fluid supply hose to the gun fluid fitting. Connect a grounded return hose to the other port.

In a non-circulating system, remove the gun fluid outlet fitting (G) and plug the outlet port with the pipe plug (109) supplied.

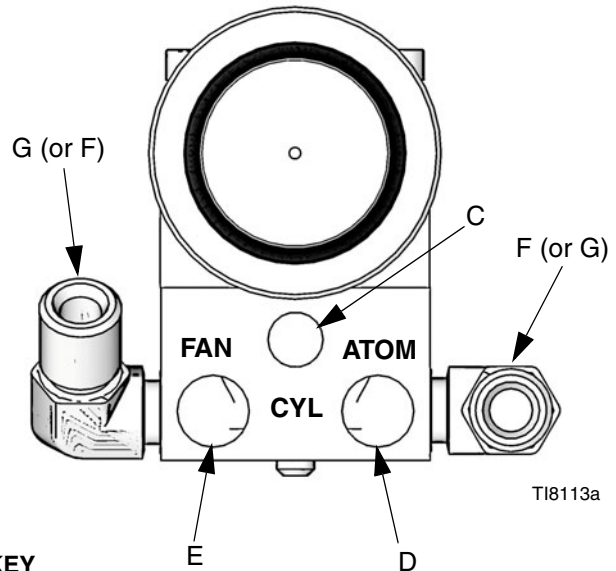

KEY

- C Cylinder Air Inlet: accepts 1/4 in. (6.3 mm) O.D. tubing
- D Atomization Air Inlet: 1/4-18.6 npsm
- E Fan Air Inlet: 1/4-18.6 npsm
- F Fluid Inlet: 1/4-18 nptf or #5 JIC (1/2-20 unf)
- G Fluid Outlet (circulating gun only): 1/4-18 nptf or #5 JIC (1/2-20 unf)

FIG. 6: Side Mounted Manifold Ports

Setup

Flush Spray Gun



Before running any paint through the spray gun:

1. Flush the gun with a solvent that is compatible with the fluid to be sprayed, using the lowest possible fluid pressure and grounded metal container.
2. Perform **Pressure Relief Procedure**; see page 12.

Select a Spray Tip and Air Cap

The fluid flow and pattern width depend on the size of the spray tip, the fluid viscosity, and the fluid pressure. See page 31 and page 32 for spray tip selection charts. Contact your Graco distributor for assistance in selecting an appropriate spray tip for your application.

Install a Spray Tip

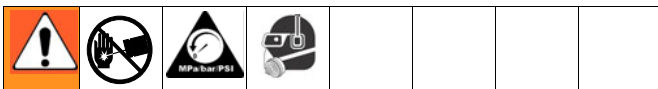

1. Perform **Pressure Relief Procedure**, page 12.
2. Install a spray tip in the gun.
3. Align tip locating tab with slot on the air cap. See FIG. 7.
4. Tighten the air cap retaining ring (8) firmly by hand to ensure a good seal between the tip gasket and the diffuser (10).



FIG. 7

Position the Air Cap

The air cap and spray tip position determines the direction of the spray pattern.

Rotate the air cap (the spray tip rotates with it) as needed to achieve the desired spray pattern direction. See FIG. 8.

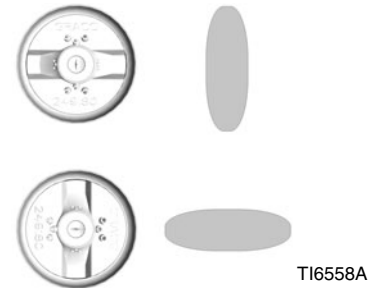

FIG. 8

Air Cap Alignment Pin

Air caps are factory-set with an air cap alignment pin to position the air cap. The standard location of the air cap alignment pin is the vertical spray pattern.

To change the spray pattern direction, use a needle nose pliers to unscrew the pin and relocate it to the desired position. See FIG. 9. When relocating the pin use low-strength thread locker. Torque to 1.5-2.5 in-lb (0.2-0.3 N•m). **Do not overtighten.**

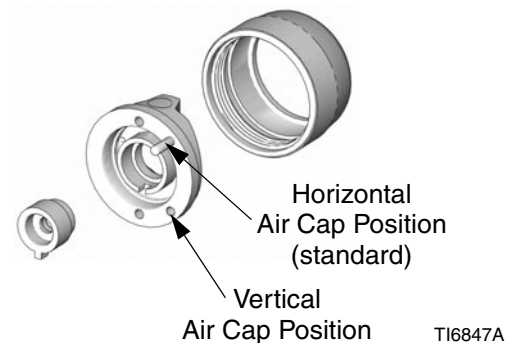
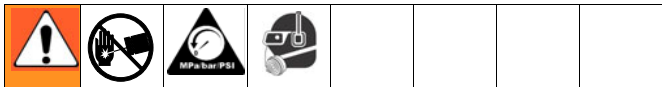

FIG. 9

Operation

Pressure Relief Procedure



1. Turn off the air and fluid supply to the gun.
2. Close the bleed-type master air valve (required in the system).
3. Trigger the gun into a grounded metal waste container to relieve the fluid pressure.

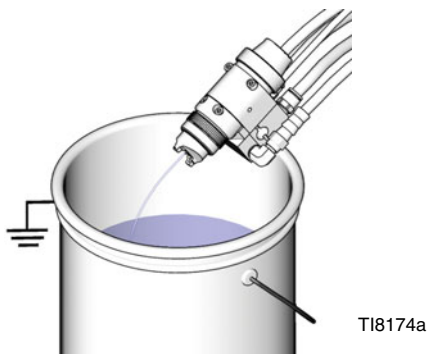



FIG. 10: Pressure Relief

4. Open the pump drain valve (required in the system) to relieve fluid pressure in the displacement pump. In addition, open the drain valve connected to the fluid pressure gauge (in a system with fluid regulation) to relieve fluid pressure in the hose and gun. Have a container ready to catch the drainage.
5. Leave the drain valve(s) open until you are ready to spray again.
6. If you suspect that the spray tip or hose is completely clogged or that pressure has not been fully relieved, very slowly loosen the hose end coupling and relieve pressure gradually, then loosen the coupling completely. Clear the tip or hose obstruction.

Adjust Spray Pattern

The air-assisted spray gun combines airless and air spray concepts. The spray tip shapes the fluid into a fan pattern, as does a conventional airless spray tip. Air from the air cap further atomizes the fluid and completes the atomization of the paint tails into the pattern to produce a more uniform pattern.

The fan air can be used if necessary to slightly adjust the pattern size.

 Air-assisted spray guns differ from air spray guns in that increasing the fan air reduces the pattern width. To increase the pattern width, use less fan air or a larger size tip.



1. Set the fluid pressure at 300 psi (2.1 MPa, 21 bar) with the fluid regulator.
2. Trigger the gun to check the atomization; do not be concerned about the pattern shape yet.
3. Slowly Increase the fluid pressure just to the point where a further increase in fluid pressure does not significantly improve fluid atomization.
4. Turn on the atomizing air and set the air pressure at about 10 psi (70 kPa, 0.7 bar). Check the spray pattern, and then adjust the air pressure until the tails are completely atomized and pulled into the spray pattern. See FIG. 11. Do not exceed 100 psi (0.7 MPa, 7 bar) air pressure to the gun.

 For HVLP operation do not exceed 10 psi at the air cap. Use HVLP verification kit 249140 to measure the atomization pressure at the air cap.

For a narrower pattern, supply air to the gun fan air inlet (or open the fan adjustment valve on manifold 288223). The tip size is the primary controller of the pattern size. Use the fan air only as needed to slightly adjust the pattern size.

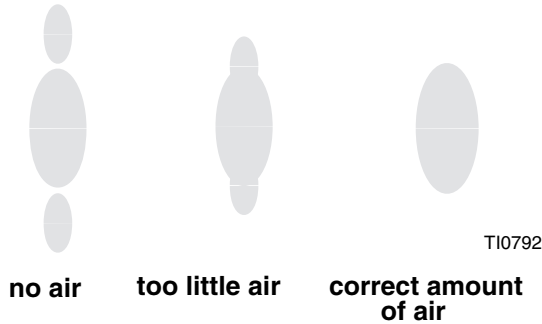

FIG. 11: Correct Spray Pattern

Apply Fluid

The spray gun has a built-in lead and lag operation. When triggered, the gun begins emitting air before the fluid is discharged. When the trigger actuation air is stopped, the fluid stops before the air flow stops. This helps assure the spray is atomized and prevents fluid buildup on the air cap and tip.

Adjust the system control device, if it is automatic, so the gun starts spraying just before meeting the work piece and stops as soon as the work piece has passed. Keep the gun a consistent distance, 8 to 10 inches (200 to 250 mm), from the surface of the object being sprayed.

To achieve best results when applying fluid:

- Keep gun perpendicular and 8 to 10 inches (200 to 250mm) from object being sprayed.
- Use smooth, parallel strokes across surface to be sprayed with 50% overlap. See FIG. 12.

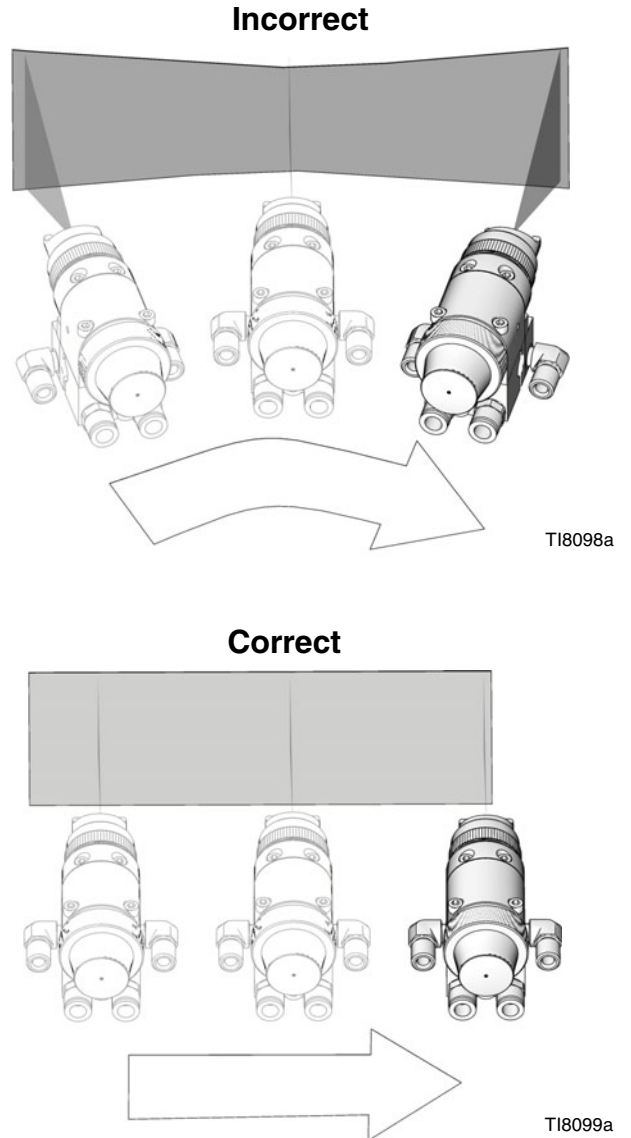
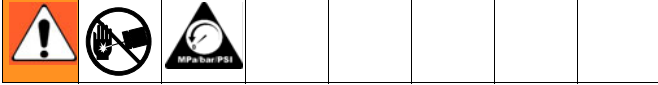

FIG. 12: Correct Spray Method

Maintenance

Daily Gun Care



CAUTION
Methylene chloride with formic or propionic acid is not recommended as a flushing or cleaning solvent with this gun as it will damage aluminum and nylon components.

CAUTION

Solvent left in gun air passages could result in a poor quality paint finish. Do not use any cleaning method which may allow solvent into the gun air passages.
Do not point the gun up while cleaning it.

Do not wipe the gun with a cloth soaked in solvent; ring out the excess.

Do not immerse the gun in solvent.

Do not use metal tools to clean the air cap holes as this may scratch them; scratches can distort the spray pattern.



TI8100a



TI4827a



TI8101a



TI6565a

General System Maintenance

1. Perform **Pressure Relief Procedure**, page 12.
2. Clean the fluid and air line filters daily.
3. Check for any fluid leakage from the gun and fluid hoses. Tighten fittings or replace equipment as needed.
4. Flush the gun before changing colors and whenever you are done operating the gun.

Flushing and Cleaning



To reduce the risk of serious injury, including splashing fluid in the eyes or on the skin, or static electric discharge when flushing:

- Ensure that the entire system, including flushing pails, are properly grounded.
- Remove the spray tip.
- Maintain metal to metal contact between the gun and the flushing pail.
- Use the lowest possible pressure.

CAUTION

This gun is not adjustable. To ensure proper shutoff, screw the piston cap (27) onto the housing (1) until it bottoms out.



- Flush before changing colors, before fluid can dry in the equipment, at the end of the day, before storing, and before repairing equipment.
- Flush at the lowest pressure possible. Check connectors for leaks and tighten as necessary.
- Flush with a fluid that is compatible with the fluid being dispensed and the equipment wetted parts.
- If it is available, the flushing procedure provided in the pump or sprayer manual should be used instead of this procedure.
- Clean the front of the tip frequently during the day to reduce buildup.

1. Perform **Pressure Relief Procedure**, page 12.
2. Shut off the gun fan and atomizing air.
3. Remove the air cap retaining ring (8), air cap (30), and spray tip (9).
4. Disconnect the fluid supply hose and air supply hose from the gun.
5. Connect the solvent supply hose to the gun.
6. Increase the pressure slowly. Point the gun down into a grounded metal container, and flush the gun with solvent until all traces of fluid are removed from the gun passages.

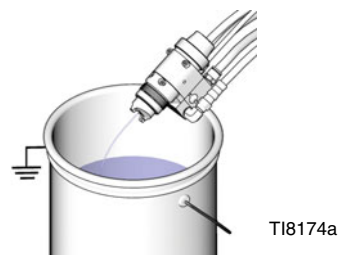

FIG. 13

Maintenance

7. Turn off the solvent supply.
8. Perform **Pressure Relief Procedure**, page 12.
9. Disconnect the solvent supply hose from the gun.
10. Dip the end of a soft-bristle brush into a compatible solvent. Do not continuously soak the brush's bristles with solvent and do not use a wire brush.



FIG. 14

11. With the gun pointed down, clean the front of the gun, using the soft-bristle brush and solvent.

12. Scrub the air cap retaining ring (8), air cap (30), and spray tip (9) with the soft-bristle brush. To clean out air cap holes, use a soft tool, such as a toothpick, to avoid damaging critical surfaces. Blow air through the spray tip to ensure the orifice is clean. Clean the air cap and spray tip daily, minimum. Some applications require more frequent cleaning.

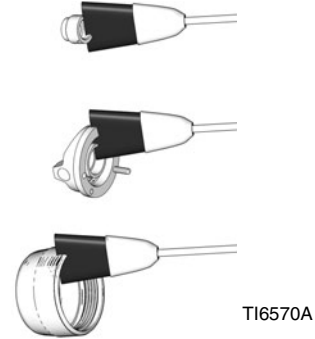
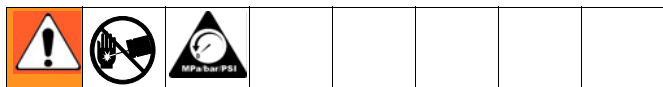



FIG. 15

13. Install the air cap retaining ring (8), air cap (30), and spray tip (9).
14. Dampen a soft cloth with solvent and wring-out the excess. Point the gun down and wipe off the outside of the gun.

Troubleshooting



 Check all possible remedies in the troubleshooting charts before disassembling the gun.



Some improper patterns are caused by the improper balance between air and fluid. Refer to **Spray Pattern Troubleshooting**, page 19.

General Troubleshooting

Problem	Cause	Solution
Fluid leakage through venting holes.	Worn packings or needle.	Replace needle assembly. (14)
Air leakage through venting hole.	Worn o-ring (23) or gasket (15).	Check and replace parts as needed.
Air leakage from back of gun.	Worn o-rings (22, 23).	Replace o-rings.
Air does not trigger.	Piston stem is disconnected from main body of piston assembly (20).	Replace piston assembly.
Air does not shut off.	Piston assembly not seating properly.	Clean/service piston assembly. Replace worn or swollen o-rings.
	Broken return spring (29).	Replace spring.
	Swollen o-ring (22).	Replace o-rings.
	Worn piston stem o-rings (25, 26).	Replace o-rings.
	Bottom gasket (16) failed.	Replace gasket.
Fluid leakage from front of gun.	Fluid needle (14) dirty, worn, or damaged.	Clean or replace fluid needle.
	Dirty or worn diffuser-seat (10).	Clean or replace diffuser-seat. To improve sealing while spraying lightweight materials and sealing life while spraying acid catalyzed materials, use optional SST ball and plastic seat.
Fluid is present at air cap holes.	Spray tip is leaking,	Verify that retainer (8) or RAC air cap assembly (30), are tight. If so, replace spray tip (9).
	Diffuser-seat (10) is insufficiently tightened.	Tighten diffuser-seat.

Problem	Cause	Solution
Fluid needle will not trigger.	<p>Loose or missing fluid needle stop (21) or setscrew (19).</p> <p>Broken fluid needle (14).</p> <p>Air leaking around piston (20).</p> <p>Swollen piston o-ring (22).</p> <p>Insufficient air pressure on trigger.</p> <p>Spray tip (9) is plugged.</p> <p>Fluid filter is plugged.</p> <p>Plug (5) is in incorrect fluid port.</p>	<p>Replace stop or tighten setscrew.</p> <p>Replace fluid needle.</p> <p>Replace o-ring (22) or piston assembly (20).</p> <p>Replace o-ring. Do not immerse piston in solvent.</p> <p>Increase air pressure or clean air line.</p> <p>Clean spray tip and air cap (30).</p> <p>Clean or replace filter.</p> <p>Move plug to fluid port consistent with manifold plumbing, unless you are using gun in a circulating system. If you are, all fluid ports in gun and on manifold should be open.</p>
Fluid does not shut off.	<p>Worn o-ring (25).</p> <p>Piston cap (27) not fully tightened.</p> <p>Spring (28) not in place.</p> <p>Swollen piston o-ring (22).</p>	<p>Replace o-ring.</p> <p>Tighten piston cap until it bottoms out.</p> <p>Check spring position.</p> <p>Replace o-ring. Do not immerse piston in solvent</p>

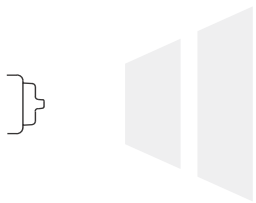
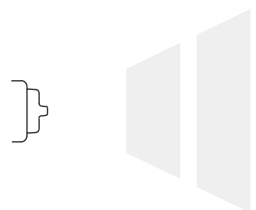
Spray Pattern Troubleshooting

Problem	Cause	Solution
<p>Fluttering spray.</p> 	<p>Insufficient fluid supply.</p> <p>Air in paint supply line.</p>	<p>Adjust fluid regulator or fill fluid supply tank.</p> <p>Check, tighten siphon hose connections, bleed air from paint line.</p>
<p>Spitting spray.</p> 	<p>Worn diffuser-seat (10) or needle (14) ball.</p> <p>Dirty spray tip (9) or air cap (30).</p>	<p>Inspect diffuser-seat and needle for wear. Replace if necessary.</p> <p>To improve sealing when spraying lightweight materials and sealing life when spraying acid catalyzed materials, use needle (SST) available with 1/8 in. ball only, and diffuser-seat (plastic). See Parts, page 25.</p> <p>Clean.</p>
<p>Irregular pattern.</p> 	<p>Fluid build-up or spray tip partially plugged.</p> <p>On defective side of pattern, air horn holes are partially or totally plugged.</p>	<p>Clean spray tip. See page 15.</p> <p>Clean air horn holes with solvent and soft brush. See page 15.</p>
<p>Pattern pushed to one side, same side of air cap gets dirty.</p>	<p>Air horn holes partially or totally plugged.</p>	<p>Clean air horn holes with solvent and soft brush. See page 15.</p>

Service

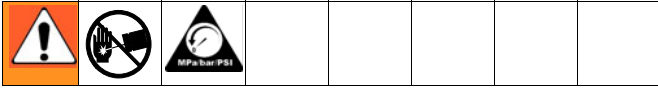

 Follow the Service Notes in FIG. 17 and FIG. 18 when reassembling the gun.

Gun repair kits are available. See page 34. Reference numbers marked with an asterisk (*) in the service procedures are included with the 288171 Air Seal Repair Kit. Reference numbers marked with a symbol (†) in the service procedures are included with the 288136 Fluid Repair Kit.

Items Needed for Service

- 1/16 in. Hex Wrench - provided
- 3 mm Hex Wrench
- Adjustable Wrench
- 4 mm Hex Wrench
- 5/16 in. Nut Driver
- Pliers
- Lubricant part no. 111265; see **Accessories**, page 34, to order
- Compatible Solvent

Disassembly

1. Perform **Pressure Relief Procedure**, page 12.
2. Unscrew the four screws (17) and remove the gun from the manifold.
3. Unscrew the air cap retainer (8). Remove the air cap (30) and spray tip (9). See FIG. 17.

Model 288053: Unscrew the air cap (30). Remove the RAC spray tip (9) and RAC housing (11). See **Parts**, page 25.

4. Inspect the tip seal (9a) in place. If damaged, replace the tip seal.
5. Remove the cap (27) from the piston housing (1). Remove the springs (28 and 29).
6. Using the supplied wrench (38), loosen the fluid needle setscrew (19). Remove the needle stop (21).
7. Trigger the gun (or remove cap (27) and springs (28, 29)) to pull the needle housing off the seat while you unscrew the diffuser (10) from the gun body (1).
8. Unscrew the needle assembly (14) and use 5/16 in. nut driver to pull the assembly straight out the front of the gun.

CAUTION

Be sure to keep the needle straight when removing it from the gun. If the needle is bent, it must be replaced.

9. Remove the piston. Using a pliers, pull the piston (20) out of the piston housing (1). See FIG. 16.

10. If gasket (15) needs to be replaced, unscrew the two screws (18) and separate the fluid housing (2) and piston housing (1). Inspect gasket (16) and replace if needed.

 Gasket (16) is attached to assembly with adhesive; therefore, if you are replacing gasket (16), ensure that a replacement gasket is available.

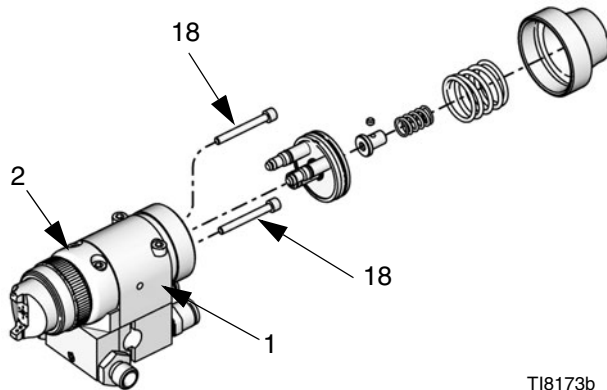

T18173b

FIG. 16

11. Remove the large o-ring (22) from the piston and the smaller o-ring (23) from the piston shaft. Remove the two o-rings (25, 26) from each of the piston stems. Check that the stems are solidly in place. If they are loose, replace the entire piston assembly (20).
12. Perform the following applicable step:
- Non-circulating guns:* Remove the fluid outlet port plug (5) and gasket (4) from the fluid housing (2). Remove the o-ring (6) and backup o-ring (7) from the plug.
 - Circulating guns:* Remove the gasket (4) from the fluid housing (2).
13. Clean all parts and replace any worn parts. When assembling, lubricate the threads with anti-seize lubricant.

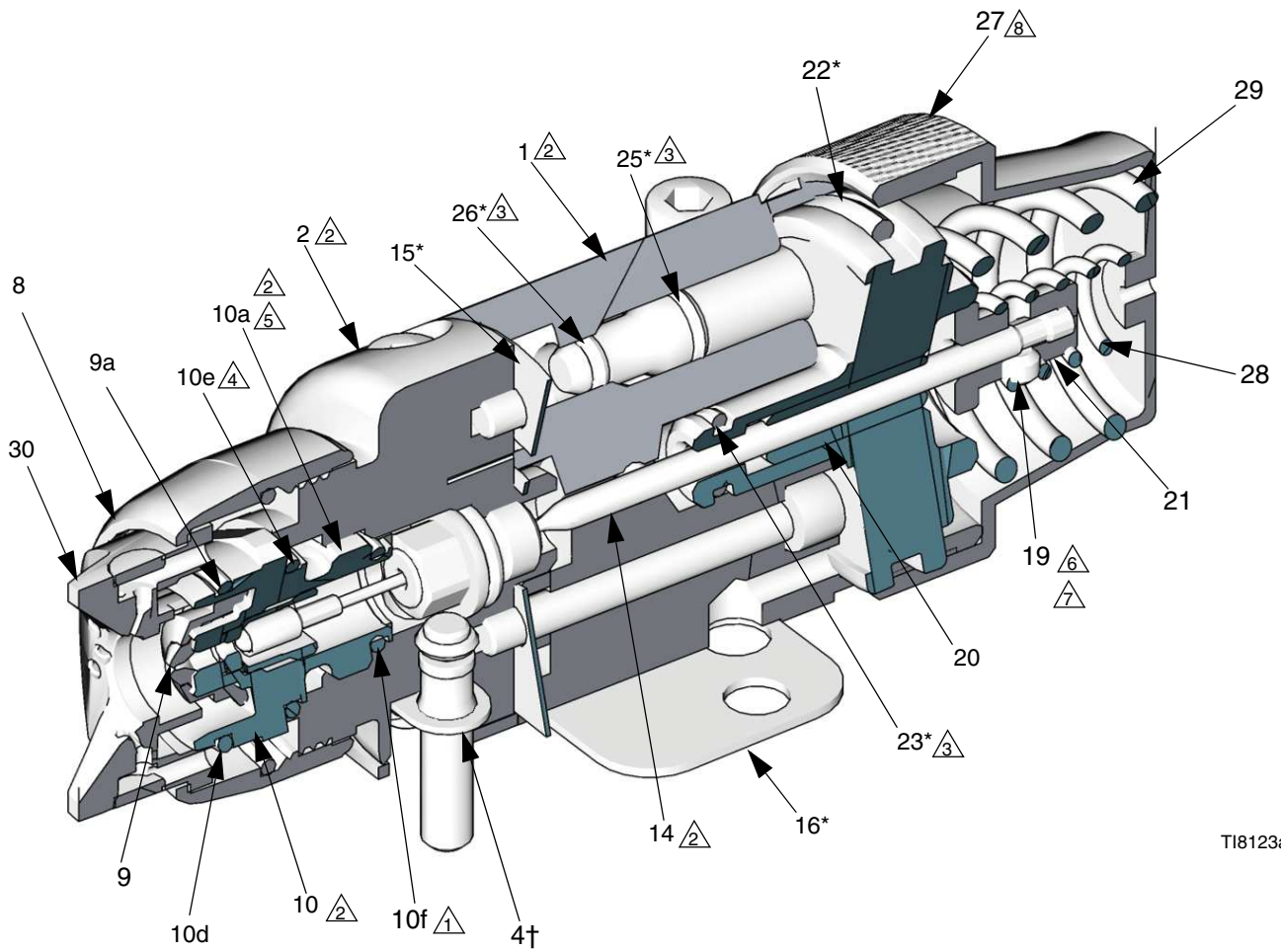

T18123a

Cutaway View:
Part No. 288044 Gun Shown

SERVICE NOTES:

- △₂ Lubricate threads with anti-seize lubricant
- △₃ Lubricate with light-weight oil
- △₄ Do not lubricate
- △₅ Torque to 155-165 in-lb (18-19 N•m)
- △₆ Apply semi-permanent anaerobic sealant
- △₇ Torque to 4-5 in-lb (0.45-0.56 N•m)
- △₈ Tighten cap (27) until it bottoms out

FIG. 17

Diffuser Seat Replacement

- See **Accessories**, page 34.
 - Clean parts with a solvent that is compatible with the parts and the fluid being sprayed.
1. Perform **Pressure Relief Procedure**, page 12.
 2. Remove gun from manifold.
 3. Remove the air cap retaining ring (8), air cap (30), and spray tip (9).
 4. Trigger the gun (or remove cap (27) and springs (28, 29)) to pull the needle housing off the seat while you unscrew the diffuser (10) from the gun body (1).
 5. Inspect the o-rings (10d, 10e, 10f) in place. Carefully remove the o-rings from the diffuser housing (10) and replace if necessary.
 6. Remove the seat nut (10c), seat (10b) and seat gasket (10g) (Carbide seat only) using a 7/32 in. hex wrench.
 7. Inspect the seat (10b) and seat gasket (10g) and replace if necessary.
 8. Reinstall the seat gasket (10g) (Carbide seat only), seat (10b), and seat nut (10c). Torque to 45-50 in-lb (5.1-5.7 N•m). Be sure not to overtighten the nut.

 When reinstalling the carbide seat, the tapered end of the seat (red side) must point toward the gun tip.

The plastic seat, standard in *Model 288044*, can be reinstalled in either direction. However, do not reverse the direction of the seat if it is worn; it must be replaced.

Reassembly

1. *Non-circulating guns only:* Lubricate the backup o-ring (7†) and o-ring (6†) and install them on the fluid outlet port plug (5). Install the plug in the fluid outlet port of the fluid housing (2). See FIG. 18.
2. *All guns:* Reinstall the gasket (4) in the fluid housing (2).
3. Install the o-rings (22*, 23*) on the piston (20). Install two o-rings (25*, 26*) on each of the piston stems. Lubricate all the o-rings, the piston, and the piston stems.
4. Align the gasket (15*) as shown in the exploded view in Fig. 8.

If replacing gasket (15), place the gasket on the piston housing (1), then install the fluid housing (2). Torque the two screws (18) to 30 in-lb (3.4 N•m)
5. Insert the piston (20) into the piston housing (1).
6. Remove the protective paper from the sticky side of the gasket (16*) and adhere the gasket to the bottom of the piston housing (1), making sure the three holes in the gasket are properly aligned with the matching holes in the housing.

CAUTION

Be sure to keep the needle straight when installing it in the piston housing. If the needle is bent it must be replaced.

7. Insert the needle assembly (14) into the front of the fluid housing (2). Tighten to 50-60 in-lb (5.7-6.8 N•m).
8. Lubricate the threads of the diffuser-seat (10). Screw it into the fluid housing (2) and torque to 65 in-lb (7.3 N•m).
9. Install the needle stop (21) on the needle. Coat the setscrew (19) with semi-permanent anaerobic sealant and install the screw into the needle stop. Torque to 4-5 in-lb (0.45-0.56 N•m). Pull on the needle to make sure it seats fully.
10. Install the springs (28, 29).
11. Lubricate the threads of the piston housing (1). Screw the cap (27) onto the housing until it bottoms out.
12. *Model 288053:* Install the RAC housing (11) and RAC spray tip (9) in the RAC air cap assembly (30). Position the blue tip guard as desired and screw the air cap assembly onto the gun until it bottoms out. See **Parts**, page 25.

Assemble the standard tip and air cap.
13. Reinstall the gun on the manifold with the four screws (17). Torque to 65 in-lb (7.3 N•m).

Parts

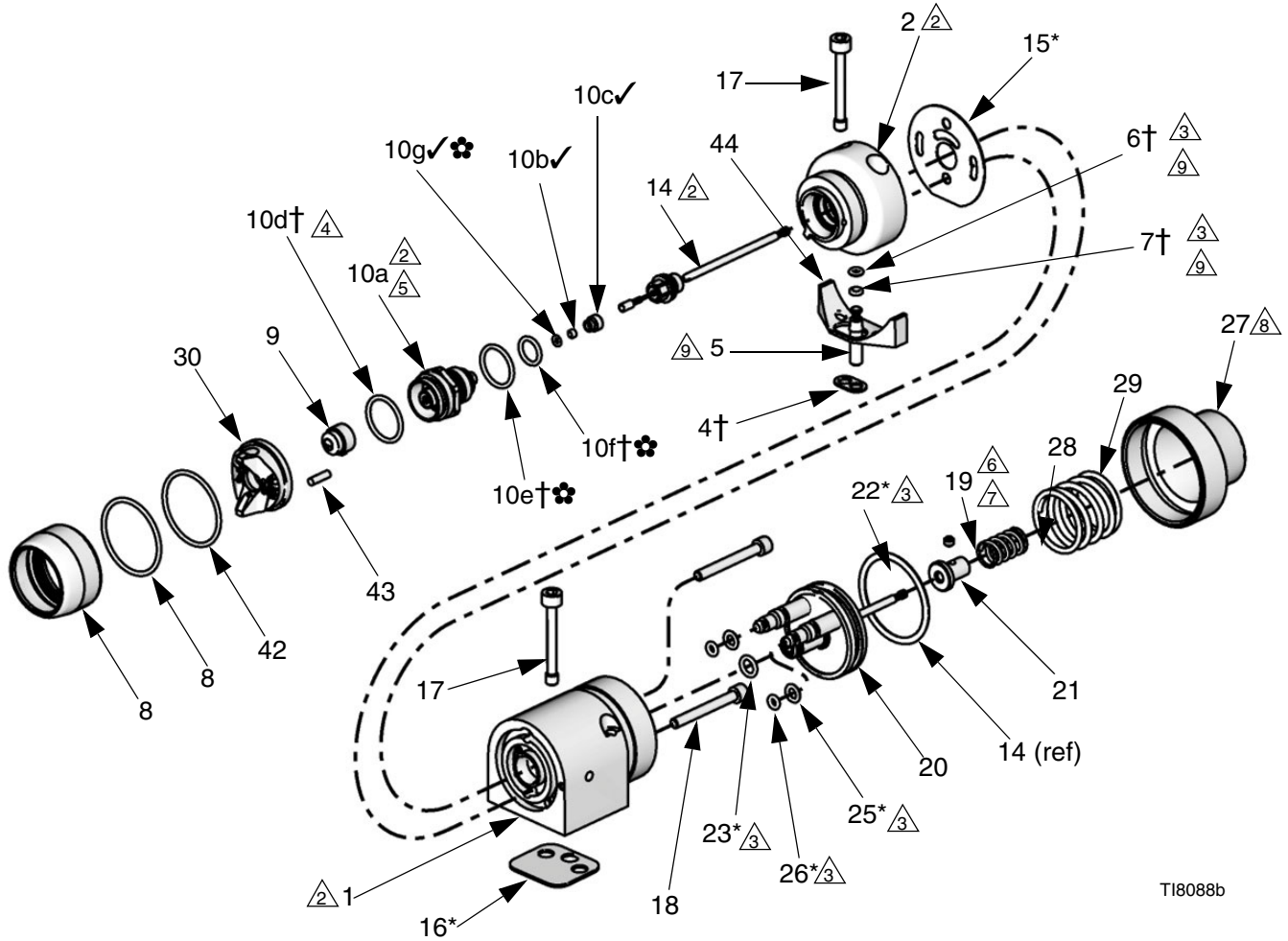

TI8088b

SERVICE NOTES:

- △₂ Lubricate threads with anti-seize lubricant
- △₃ Lubricate with light-weight oil
- △₄ Do not lubricate
- △₅ Torque to 65 in-lb (7.3 N•m)
- △₆ Apply semi-permanent anaerobic sealant
- △₇ Torque to 4-5 in-lb (0.45-0.56 N•m)
- △₈ Tighten cap (27) until it bottoms out
- △₉ Used on non-circulating guns only

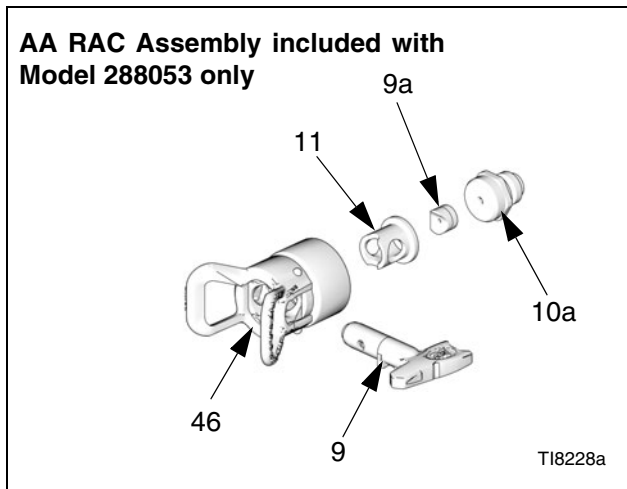

FIG. 18

Parts

Ref. No.	Part No.	Description	Qty.	Ref. No.	Part No.	Description	Qty.
1		BODY	1	16*	114134	GASKET, polyethylene (bottom)	1
2		HOUSING, fluid, SST	1	17	15H317	SCREW, mounting manifold (M5)	4
4	288200	GASKET, fluid, plastic homopolymer, pack of 10	2	18	15H318	SCREW, SHCS	4
5	192687	PLUG, fluid, internal, SST	1	19	114137	SCREW, set; 6-32, 1/8 in. long	1
6	114244	PACKING, o-ring, fluoroelastomer	1	20	240895	PISTON, assy	1
7	114340	RING, back-up, PTFE		21	192452	STOP, needle, SST	1
8◆❖*	249134	RING, retaining, assy	1	22*	115066	PACKING, o-ring, fluoroelastomer	1
8a	109213	O-RING, PTFE (see Kit 253032, p. 35, for pack of 5)	1	23*	111450	PACKING, o-ring, fluoroelastomer	1
9		TIP, includes 9a, see tip selection charts, page 29	1	25*	112319	PACKING, o-ring, fluoroelastomer	2
	AAPxxx	Model 288044		26*	111504	PACKING, o-ring, fluoroelastomer	2
	LTXxxx	Model 288053, includes 9a		27	192453	CAP, piston	1
10		DIFFUSER, assy	1	28	114138	SPRING, compression	1
	249132	with plastic seat Model 288044		29	114139	SPRING, compression	1
	288192	with Carbide seat Models 288046, 288053		30◆❖	288194	CAP, air, assy	1
	249877	with RAC seat Model 288053		*	289080	CAP, air, assy	1
10a		DIFFUSER, housing	1	38	114141	WRENCH, hex (not shown)	1
10b ✓		SEAT	1	42◆❖*	15G320	WASHER, PTFE, 1.2 in. O.D. (see Kit 253032, p. 35, for pack of 5)	1
10c ✓		NUT, seat	1	43◆❖*	15G618	PIN, locating, threaded	1
10d †	111116	PACKING, o-ring, seat; PTFE	1	44	15H702	INSERT, plastic	1
10e †❖	109450	PACKING, o-ring; PTFE	1	46★	249478	GUARD, RAC, G40	1
10f †❖	111457	PACKING, o-ring; PTFE	1				
10g ✓❖	15F409	GASKET, seat (Diffuser assy with carbide seat only)	1				
11★	15J770	HOUSING, RAC	1				
14		NEEDLE, assy	1				
	288190	SST ball Model 288044					
	288191	Carbide ball Models 288046, 288053					
15*	15H316	GASKET, polyethylene (front)	1				

◆ Model 288044 only.
❖ Model 288046 only.
★ Model 288053 only.
* Model 24F835 only.
† Included in Fluid Seal Repair Kit 288136.
* Included in Air Seal Repair Kit 288171.
✓ Included in Seat Repair Kits 249424 (plastic) or 249456 (carbide).
❖ Part not for sale.

Part No. 288217

North America Manifold with side fluid ports

Part No. 288218

International Manifold with side fluid ports

Ref.

Ref. No.	Part No.	Description	Qty.
101		MANIFOLD, side fluid ports	1
103			1
	120388❖	FITTING, tube, air inlet; 1/4 in. OD tube x 1/8 npt(m)	
	120538◆	FITTING, tube, air inlet; 6 mm OD tube x 1/8 npt(m)	
105	114246	SCREW, set; 5/16;0.437 in. long	1
107			2
	114342❖	ELBOW, street, 1/4 in. npt	
	114247◆	FITTING, elbow, male; #5 JIC x 1/4 npt	
108			2
	120389❖	FITTING, tube, air line; 3/8 in.OD tube x 1/4 npt	
	120537◆	FITTING, tube, air line; 8 mm OD tube x 1/4 npt	
109*	101970	PLUG, pipe, SST; 1/4-18 ptf, supplied to plug fluid outlet port in non-circulating applications	3
114	120453	SCREW, SCHS, M3 x 18	1

* Not shown.

❖ Part No. 288217 only.

◆ Part No. 288218 only.

⚠ Apply anti-seize lubricant (222955) to threads and mating faces of manifold (101) and any fittings and/or plugs used in fluid ports.

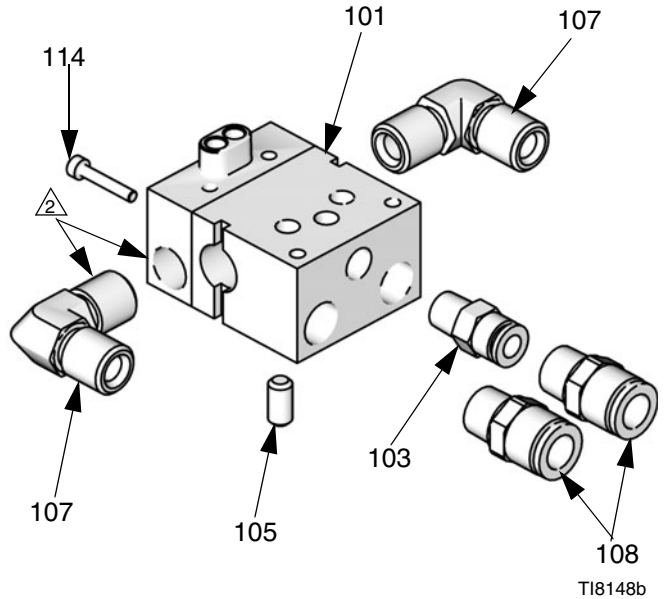

FIG. 19: North America and International Manifold

Part No. 288221

Manifold with bottom fluid ports

Ref. No.	Part No.	Description	Qty.
101		MANIFOLD, bottom fluid ports	1
103	120388	FITTING, tube, air inlet; 1/4 in. OD tube x 1/8 npt(m)	1
105	114246	SCREW, set; 5/16;0.437 in. long	1
107	166846	NIPPLE, SST; 1/4 npsm, straight pipe thread x 1/4 npt	2
108	120389	FITTING, tube, air line; 3/8 in.OD tube x 1/4 npt	2
109*	101970	PLUG, pipe, SST; 1/4-18 ptf, supplied to plug fluid outlet port in non-circulating applications	1
114	120453	SCREW, SCHS, M3 x 18	1

* Not shown.

⚠ Apply anti-seize lubricant (222955) to threads and mating faces of manifold (101) and any fittings and/or plugs used in fluid ports.

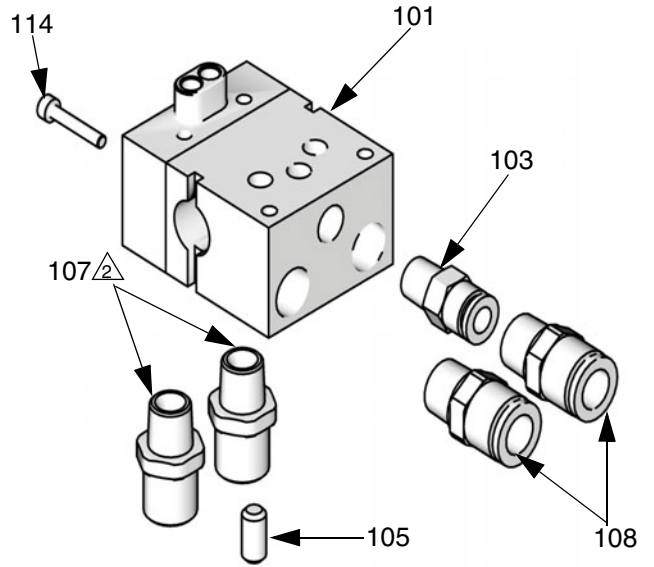

T19398b

FIG. 20: Manifold with Bottom Fluid Ports

Part No. 288224

High Pressure Air-Assisted Manifold with side fluid ports and fan adjustment valve

Part No. 24C343

International Manifold with side fluid ports

Ref.

No.	Part No.	Description	Qty.
101	----	MANIFOLD, fan adjustable	1
102	244029	VALVE, fan, assy.	1
103		FITTING, tube, air inlet	1
	120388❖	1/4 in. OD tube x 1/8 npt(m)	
	120538◆	6 mm OD tube x 1/8 npt(m)	
104		FITTING, tube, air line	1
	120389❖	3/8 in.OD tube x 1/4 npt	
	120537◆	8 mm OD tube x 1/4 npt	
	15D916◆*	4 mm OD tube x 1/4 npt; shipped loose	
107	114246	SCREW, set; 5/16;0.437 in. long	1
108		ELBOW, male	2
	114342❖	1/4 - 18 npt	
	114247◆	#5 JIC x 1/4-18 npt	
109*	101970	PLUG, pipe, SST; 1/4-18 ptf, supplied to plug fluid outlet port in non-circulating applications	1
114	120453	SCREW, SCHS, M3 x 18	1

* Not shown, optional size.

---- Not sold separately.

❖ Part No. 288224 only.

◆ Part No. 24C343 only.

⚠ Apply anti-seize lubricant (222955) to threads and mating faces of manifold (101) and any fittings and/or plugs used in fluid ports.

⚠ Install with valve turned fully counterclockwise to outermost position.

⚠ Torque to 125-135 in-lb (14-15 N•m).

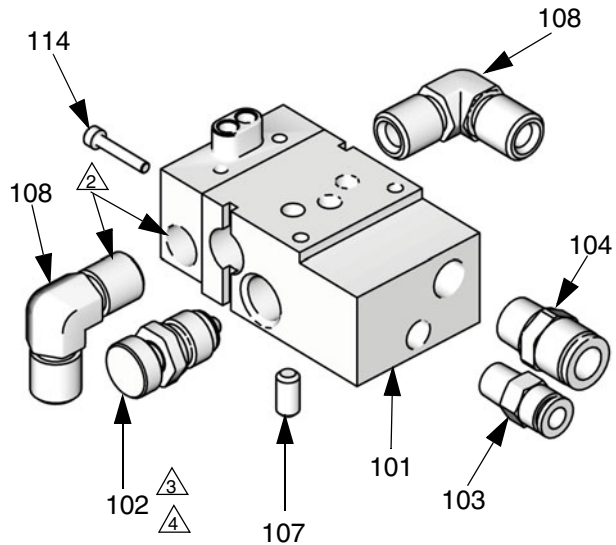

TI0556b

FIG. 21: Side Fluid Ports and Fan Adjustment Valve

Part No. 288160

Rear Port Manifold, North America

Part No. 288211

Rear Port Manifold, International

Ref.

No.	Part No.	Description
101		MANIFOLD, aluminum
103		FITTING, fluid path
	15H521❖	1/4 npsm
	15J003◆	#5 JIC
105	116475	SCREW, SHCS, M4 x 12
106	120353	O-RING, PTFE
107	15J077	O-RING, PTFE
110	103253	SCREW, set
111		
	120389❖	FITTING, tube, air line; 3/8 in.OD tube x 1/4 npt
	120537◆	FITTING, tube, air line; 8 mm OD tube x 1/4 npt
112		
	120388❖	FITTING, tube, air inlet; 1/4 in. OD tube x 1/8 npt(m)
	120538◆	FITTING, tube, air inlet; 6 mm OD tube x 1/8 npt(m)
113	114246	SCREW, set, hex soc

❖ Part No. 288160 only.

◆ Part No. 288211 only.

Qty.

1
2
2
2
2
2
2
1
1

① Apply sealant to threads and mating faces of manifold (101) and any fittings and/or plugs used in fluid ports.

② Torque to 30-42 in-lb (3.4-4.7 N•m).

③ Torque to 110-130 in-lb (12.3- 14.7 N•m).

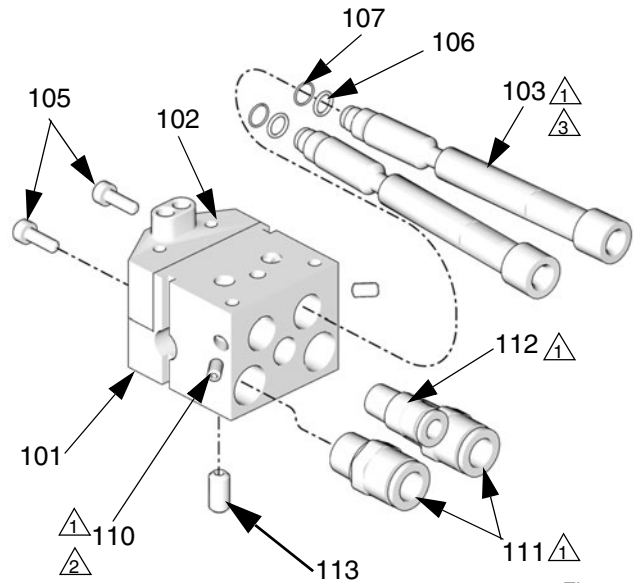

T18200a

FIG. 22:

AAP Series Tip and Air Cap Selection Charts

AAP Series Precision Spray Tips



Order desired tip (Part No. AAPxxx) where xxx is the size code for the chart.

Tips are physically marked with Xxxx, where xxx is the size code from the chart.

Orifice Size in. (mm)	* Fluid Output, fl oz/min (lpm)		Maximum Pattern Width at 12 in. (300mm) Pattern Width Tolerance +/- 0.5 in. (13.0 mm)						
	at 600 psi (4.1 MPa, 41 bar)	at 1000 psi (7.0 MPa, 70 bar)	5 (127)	7 (178)	9 (228)	11 (279)	13 (330)	15 (381)	17 (432)
† 0.009 (0.229)	7.0 (0.2)	9.1 (0.27)	209	309	409	509			
† 0.011 (0.279)	10.0 (0.3)	13.0 (0.4)	211	311	411	511	611		
0.013 (0.330)	13.0 (0.4)	16.9 (0.5)	213	313	413	513	613	713	
0.015 (0.381)	17.0 (0.5)	22.0 (0.7)	215	315	415	515	615	715	815
0.017 (0.432)	22.0 (0.7)	28.5 (0.85)		317	417	517	617	717	817
0.019 (0.483)	28.0 (0.8)	36.3 (1.09)			419	519	619	719	
0.021 (0.533)	35.0 (1.0)	45.4 (1.36)			421	521	621		

* Tips are tested in water.

† Tip sizes include a 150 mesh tip filter

Fluid output (Q) at other pressures (P) can be calculated by this formula: $Q = (0.041) (QT) \sqrt{P}$
 where QT = fluid output (fl oz/min) from the above table for 600 psi.

Air Cap

Application	Tip Used With	Typical Air Consumption	Part No.
Standard	All AAP, GG4, GG5, and AAM Series	3-6 scfm	288194

LTX Series RAC Tip Selection Charts

For use with G40 RAC Housing

Orifice Size in. (mm)	* Fluid Output, fl oz/min (lpm) at 2000 psi (14.0 MPa, 140 bar)	* Maximum Pattern Width at 12 in. (300 mm)				
		4 to 6 (150)	6 to 8 (200)	8 to 10 (250)	10 to 12 (300)	12 to 14 (350)
0.009 (0.229)	11.2 (0.33)	209	309			
0.011 (0.279)	16.6 (0.49)	211	311	411	511	
0.013 (0.330)	23.3 (0.69)	213	313	413	513	
0.015 (0.381)	30.8 (0.91)	215	315	415	515	615
0.017 (0.432)	39.5 (1.17)	217	317	417	517	617
0.019 (0.483)	49.7 (1.47)	219	319	419	519	619
0.021 (0.533)	60.5 (1.79)		321	421	521	621
0.023 (0.584)	72.7 (2.15)			423	523	623
0.025 (0.635)	85.9 (2.54)				525	625
0.027 (0.686)	100.0 (2.96)				527	627
0.029 (0.737)	115.6 (3.42)					629
0.031 (0.787)	131.8 (3.90)				531	631

* Tips are tested in water.

* Pattern width measured without airflow.

LTX Reverse-A-Clean (RAC) Spray Tips

- LTX RAC spray tips include a metal fluid seat and rubber fluid seal.
- G40 RAC conversion kits are available. See page 32.

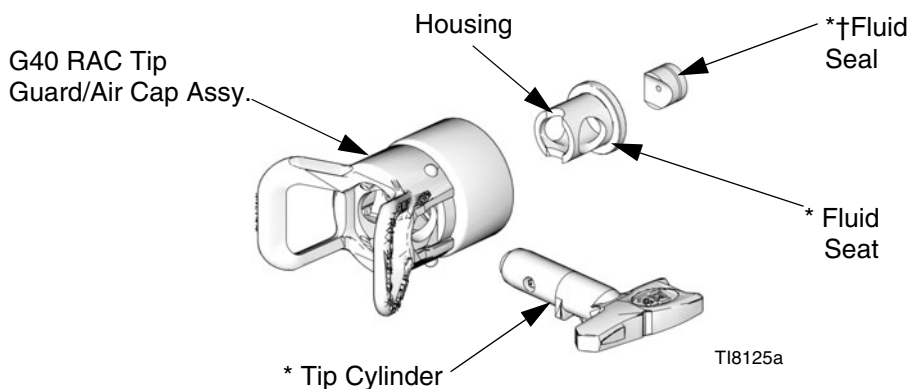

FIG. 23

* Included with the LTX RAC spray tip.

† Optional acetal fluid seal 248936 (pack of 5) available.

RAC Switch Tips

FFT Fine Finish RAC Spray Tips



Order desired tip (Part No. FFTxxx) where xxx is the size code for the chart.

Orifice Size in. (mm)	* Fluid Output, fl oz/min (lpm)	❖ Maximum Pattern Width at 12 in. (305 mm)				
	at 2000 psi (14.0 MPa, 140 bar)	4 to 6 (150)	6 to 8 (200)	8 to 10 (250)	10 to 12 (300)	12 to 14 (350)
0.008 (0.203)	8.8 (0.26)	208	308			
0.010 (0.254)	13.9 (0.41)	210	310	410	510	
0.012 (0.305)	19.9 (0.59)	212	312	412	512	612
0.014 (0.356)	27.0 (0.80)	214	314	414	514	614

WRX Wide RAC Spray Tips



Order desired tip (Part No. WRXxxx) where xxx is the size code for the chart.

Orifice Size in. (mm)	* Fluid Output, fl oz/min (lpm)	❖ Maximum Pattern Width at 12 in. (305 mm)
	at 2000 psi (14.0 MPa, 140 bar)	24 in. (610)
0.021 (0.533)	60.5 (1.79)	1221
0.023 (0.584)	72.7 (2.15)	1223
0.025 (0.635)	85.9 (2.54)	1225
0.027 (0.686)	100.0 (2.96)	1227
0.029 (0.737)	115.6 (3.42)	1229
0.031 (0.787)	131.8 (3.90)	1231
0.033 (0.838)	149.4 (4.42)	1233
0.035 (0.889)	168.3 (4.98)	1235
0.037 (0.940)	187.9 (5.56)	1237
0.039 (0.991)	208.9 (6.18)	1239

* Tips are tested in water.

❖ Measured with NO airflow. Air assist will tend to reduce pattern lengths by 1 in. to 2 in.

Accessories

Gun Manifolds

Order separately; not included with gun
(See **Parts**, page 25)

Part No. 288217

North America Manifold with side fluid ports

Part No. 288218

International Manifold with side fluid ports

Part No. 288221

Manifold with bottom fluid ports

Part No. 288224

High Pressure Air Assisted Manifold with side fluid ports and manual fan adjustment valve

Part No. 24C343

High Pressure Air Assisted Manifold, International

Part No. 288160

Rear port manifold, North America

Part No. 288211

Rear port manifold, International

Needle/Diffuser Options

Needles must be used only with the specified diffuser-seat to guarantee proper seating and life.

- **Standard viscosity/standard flow**
 - Fluid Needle 288191, carbide ball
 - Diffuser-Seat 288192, carbide seat
- **Acid catalyzed materials/very low viscosity materials**
 - Fluid Needle 288190, SST ball
 - Diffuser-Seat 288193, plastic seat

HVLP Air Cap Verification Kit 249140

Use to determine air pressure behind the air cap. Do not use for actual spraying.

 To be HVLP compliant, the atomizing air pressure must not exceed 10 psi (70 kPa, 0.7 bar).

Lacquer Air Cap Kit 289080

Kit includes air cap for optimized spray of lacquer materials.

RAC Gasket 246453

Pack of five standard replacement RAC gaskets.

Acetal RAC Gasket 248936

Pack of five plastic (acetal) replacement RAC gaskets.

Gasket Filter 288201

Optional 100 mesh filter that can be installed in the fluid inlet gasket (4) for added filtration. Pack of ten.

RAC Conversion Kit 287917

To convert from a gun with standard spray tip, tip guard, and air cap to Part No. 288053 gun with the AA RAC assembly. See parts list and drawing below for parts included with kit.

Ref. No.	Part No.	Description	Qty.
1	249478	CAP, air, AA RAC, assy	1
2	15J770	HOUSING, RAC	1
3	LTXxxx	TIP, cylinder; tip of choice; includes item 3a	2
3a		SEAT, fluid	1
4	249877	SEAT, diffuser	1

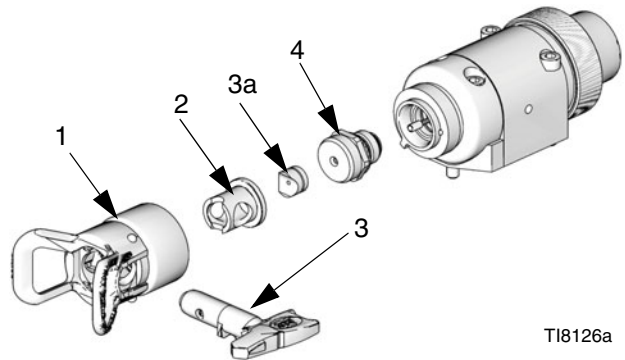

 Tip (3) is not included with kit; order separately. See **LTX Series RAC Tip Selection Charts**, page 32.

Air Cap Seal Kit 253032

Pack of five seals and five o-rings for the air cap assembly.

Plastic Seat Repair Kit 249424

Kit includes replacement plastic seat (pack of ten), and seat nut.

SST Seat Repair Kit 287962

Kit includes assembled diffuser with SST seat (15H282) for use with pigmented acid catalyzed materials.

Carbide Seat Repair Kit 249456

Kit includes replacement carbide seat, seat gasket, and seat nut.

Tip Filter Kit 241804

Replacement filters (pack of ten) for spray tip orifice sizes 0.007, 0.009, and 0.011.

Grounding Clamp and Wire 222011

In-line Fluid Filter 210500

5000 psi (35 MPa, 350 bar) Maximum Working Pressure
100 mesh. Fits onto the gun's fluid connector. 1/4-18 npsm. Includes the parts shown below.

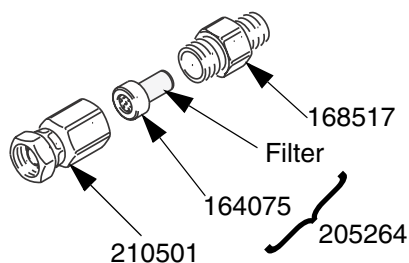

High Pressure Ball Valves, Fluoroelastomer Seals

5000 psi (34 MPa, 345 bar) Maximum Working Pressure
Can be used as fluid drain valve.

- 210657 1/2 npt(m)
- 210658 3/8 npt(m)
- 210659 3/8 x 1/4 npt(m)

Bleed-type Master Air Valve

300 psi (2.1 MPa, 21 bar) Maximum Working Pressure
Relieves air trapped in the air line between the pump air inlet and this valve when closed.

Part No. Description

107141	3/4 npt(m x f) inlet and outlet
107142	1/2 npt(m x f) inlet and outlet

Ultimate Gun Cleaning Kit 15C161

Kit includes brushes and tools for gun maintenance.

Unclogging Needle 249598

Kit includes picks for unclogging gun tip.

Brush 101892

For cleaning the gun.

Retrofit Adapter Plate 288197

The retrofit adapter plate enables the manifold to be attached to a variety of bolt patterns.

Dimensions

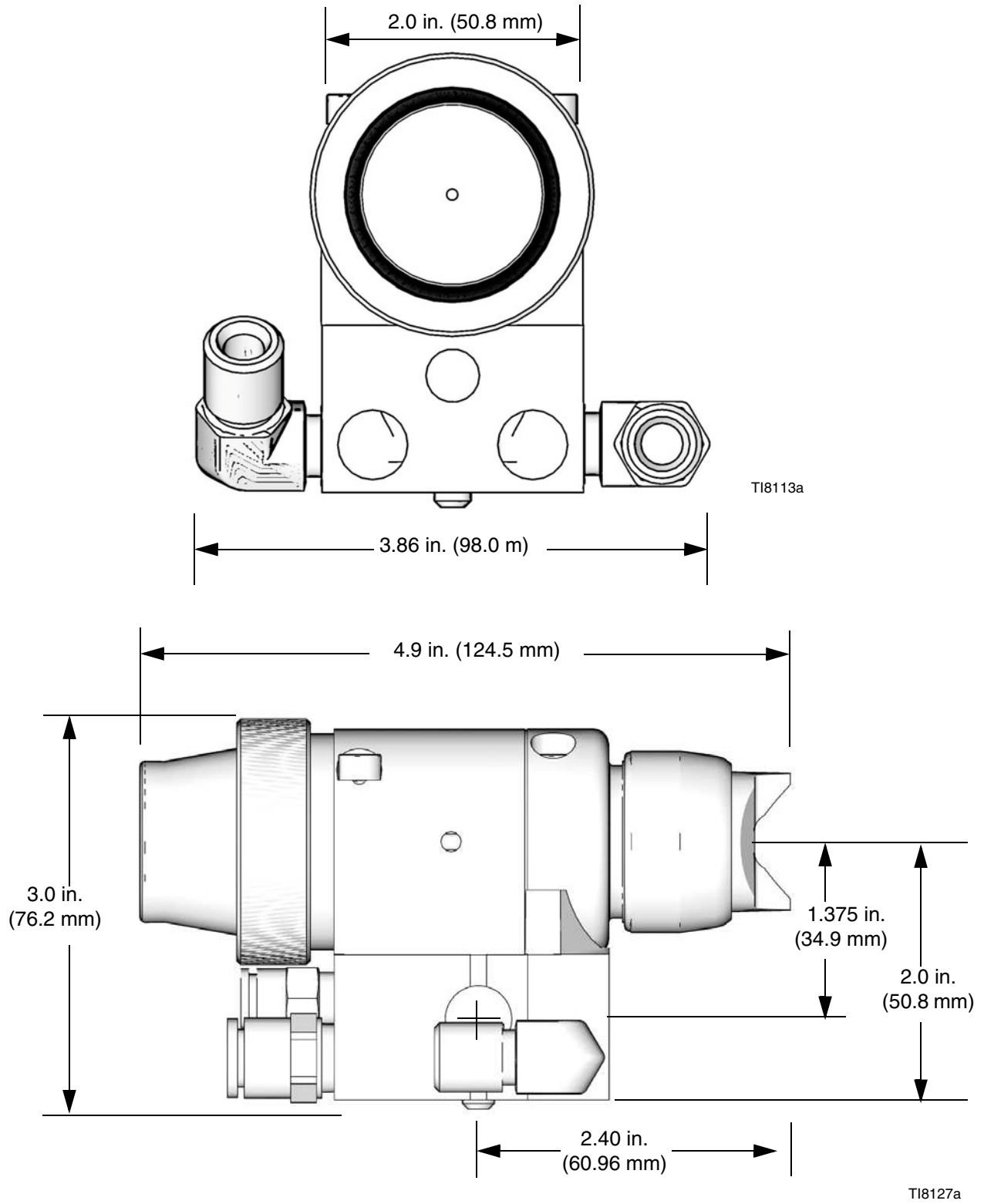

FIG. 24

Mounting Hole Layout

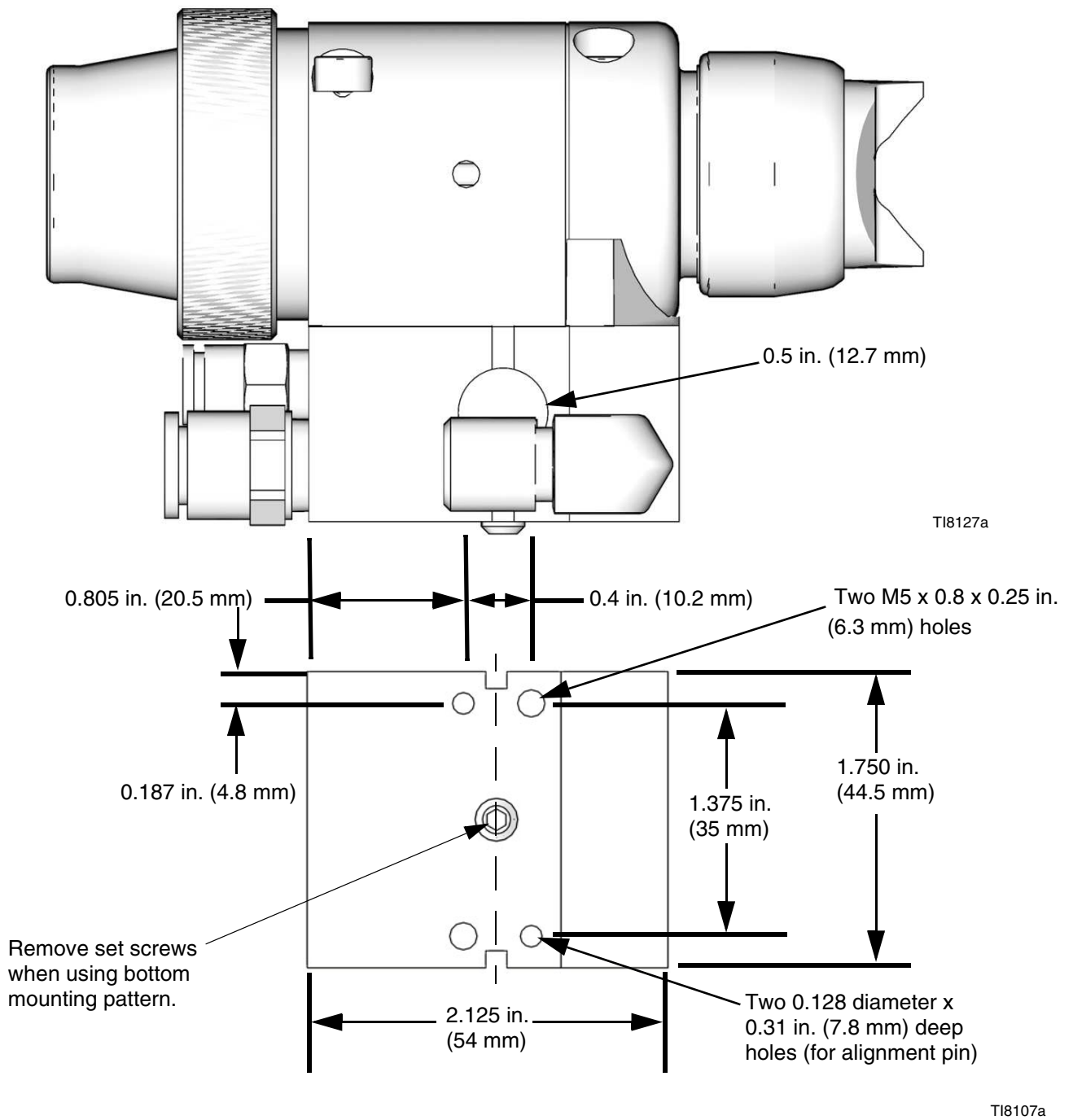
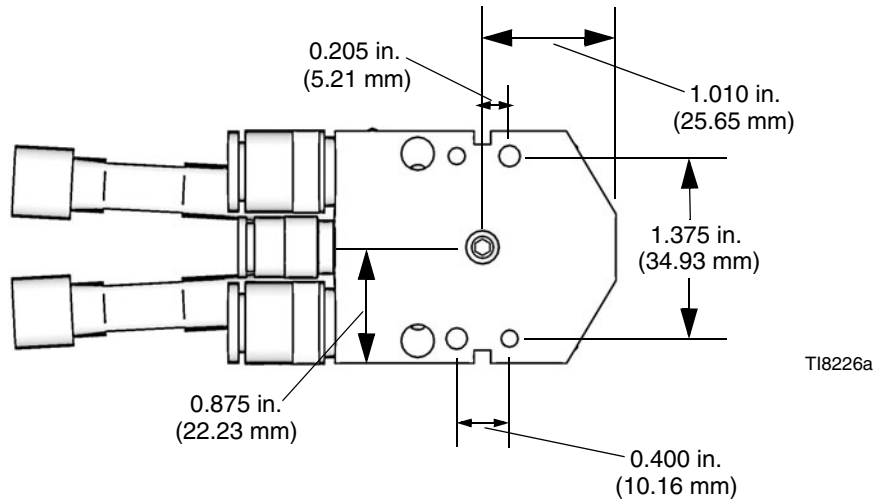

FIG. 25:

Mounting Hole Layout

Rear Port Manifold



Gun with Rear Port Manifold

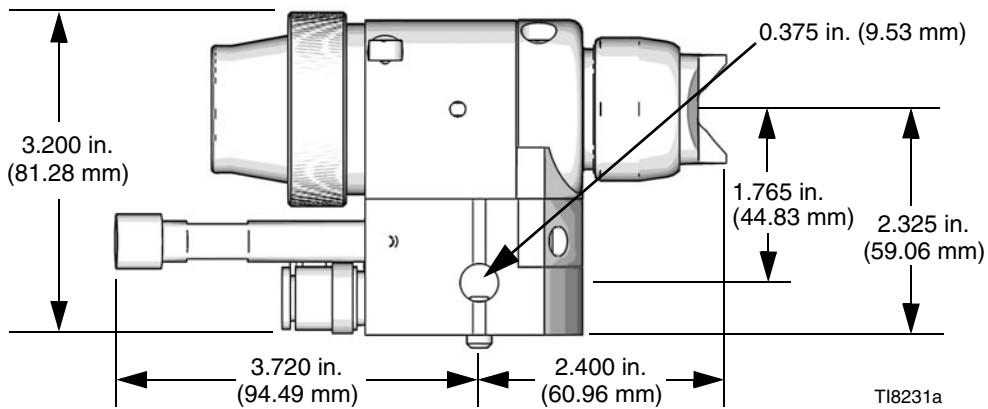

Retrofit Adapter Plate

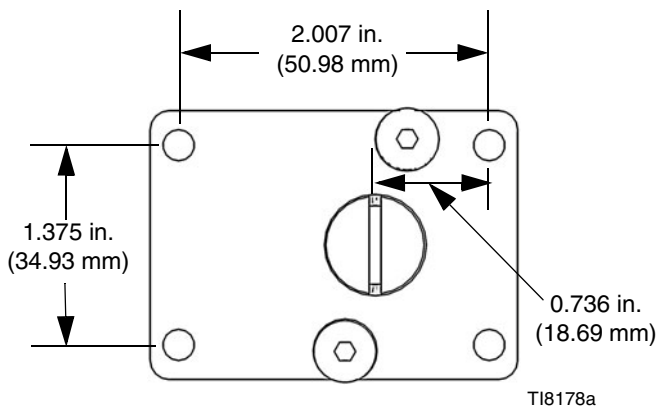

Gun with Retrofit Adapter Plate

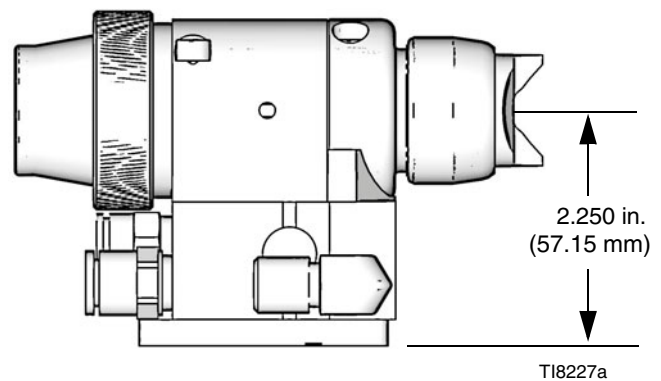

FIG. 26: Mounting Hole Layouts

Technical Data

Maximum Working Fluid Pressure	4000 psi (28 MPa, 280 bar)
Maximum Working Air Pressure	100 psi (0.7 MPa, 7 bar)
Maximum Working Fluid Temperature	120° F (49° C)
Minimum Air Cylinder Actuation Pressure	50 psi (0.34 MPa, 3.4 bar)
Weight	1.2 lbs (965 g)
Wetted Parts	Stainless Steel, Carbide, Ultra High Molecular Weight Polyethylene, Chemically Resistant Fluoroelastomer, Engineered Plastic, PTFE, Polyamide

Triggering Speed

These values apply to a new gun with a 6 ft. (1.8 m), 1/4 in. (6.3 mm) OD cylinder air line and a 0.019 in. tip. These values will vary slightly with use and with variations in equipment.

Models (3/16 in. ball)			
Cylinder Air Pressure psi (MPa, bar)	Fluid Pressure psi (MPa, bar)	msec to fully open	msec to fully close
50 (0.34, 3.4)	600 (4.2, 42)	60	60
50 (0.34, 3.4)	1800 (12.4, 124)	60	60
50 (0.34, 3.4)	4000 (28, 280)	60	60

Sound Data (dBa)

Air Cap Part No.	Operating Conditions	Fluid Pressure with 0.019 in. tip psi (MPa, bar)	Fan Air Pressure psi (MPa, bar)	Atomizing Air Pressure psi (MPa, bar)	Sound Pressure dB(A)†	Sound Power dB(A)‡
288194	Rated Pressures	4000 (28, 276)	0	100 (0.7, 7)	91.75	91.90
			100 (0.7, 7)	100 (0.7, 7)	91.22	91.46
	Normal Operating Pressures	600 (4.2, 42)	0	30 (0.21, 2.1)	83.87	76.28
			30 (0.21, 2.1)	30 (0.21, 2.1)	84.41	78.65

† Sound pressure measured 3.28 feet (1 meter) from equipment.

‡ Sound power measured per ISO-9614-2.

Graco Standard Warranty

Graco warrants all equipment referenced in this document which is manufactured by Graco and bearing its name to be free from defects in material and workmanship on the date of sale to the original purchaser for use. With the exception of any special, extended, or limited warranty published by Graco, Graco will, for a period of twelve months from the date of sale, repair or replace any part of the equipment determined by Graco to be defective. This warranty applies only when the equipment is installed, operated and maintained in accordance with Graco's written recommendations.

This warranty does not cover, and Graco shall not be liable for general wear and tear, or any malfunction, damage or wear caused by faulty installation, misapplication, abrasion, corrosion, inadequate or improper maintenance, negligence, accident, tampering, or substitution of non-Graco component parts. Nor shall Graco be liable for malfunction, damage or wear caused by the incompatibility of Graco equipment with structures, accessories, equipment or materials not supplied by Graco, or the improper design, manufacture, installation, operation or maintenance of structures, accessories, equipment or materials not supplied by Graco.

This warranty is conditioned upon the prepaid return of the equipment claimed to be defective to an authorized Graco distributor for verification of the claimed defect. If the claimed defect is verified, Graco will repair or replace free of charge any defective parts. The equipment will be returned to the original purchaser transportation prepaid. If inspection of the equipment does not disclose any defect in material or workmanship, repairs will be made at a reasonable charge, which charges may include the costs of parts, labor, and transportation.

THIS WARRANTY IS EXCLUSIVE, AND IS IN LIEU OF ANY OTHER WARRANTIES, EXPRESS OR IMPLIED, INCLUDING BUT NOT LIMITED TO WARRANTY OF MERCHANTABILITY OR WARRANTY OF FITNESS FOR A PARTICULAR PURPOSE.

Graco's sole obligation and buyer's sole remedy for any breach of warranty shall be as set forth above. The buyer agrees that no other remedy (including, but not limited to, incidental or consequential damages for lost profits, lost sales, injury to person or property, or any other incidental or consequential loss) shall be available. Any action for breach of warranty must be brought within two (2) years of the date of sale.

GRACO MAKES NO WARRANTY, AND DISCLAIMS ALL IMPLIED WARRANTIES OF MERCHANTABILITY AND FITNESS FOR A PARTICULAR PURPOSE, IN CONNECTION WITH ACCESSORIES, EQUIPMENT, MATERIALS OR COMPONENTS SOLD BUT NOT MANUFACTURED BY GRACO. These items sold, but not manufactured by Graco (such as electric motors, switches, hose, etc.), are subject to the warranty, if any, of their manufacturer. Graco will provide purchaser with reasonable assistance in making any claim for breach of these warranties.

In no event will Graco be liable for indirect, incidental, special or consequential damages resulting from Graco supplying equipment hereunder, or the furnishing, performance, or use of any products or other goods sold hereto, whether due to a breach of contract, breach of warranty, the negligence of Graco, or otherwise.

FOR GRACO CANADA CUSTOMERS

The Parties acknowledge that they have required that the present document, as well as all documents, notices and legal proceedings entered into, given or instituted pursuant hereto or relating directly or indirectly hereto, be drawn up in English. Les parties reconnaissent avoir convenu que la rédaction du présente document sera en Anglais, ainsi que tous documents, avis et procédures judiciaires exécutés, donnés ou intentés, à la suite de ou en rapport, directement ou indirectement, avec les procédures concernées.

Graco Information

For the latest information about Graco products, visit www.graco.com. For patent information, see www.graco.com/patents.

TO PLACE AN ORDER, contact your Graco distributor or call to identify the nearest distributor.

Phone: 612-623-6921 **or Toll Free:** 1-800-328-0211, **Fax:** 612-378-3505

All written and visual data contained in this document reflects the latest product information available at the time of publication. Graco reserves the right to make changes at any time without notice.

Original instructions. This manual contains English. MM 311052

Graco Headquarters: Minneapolis

International Offices: Belgium, China, Japan, Korea

GRACO INC. AND SUBSIDIARIES • P.O. BOX 1441 • MINNEAPOLIS MN 55440-1441 • USA
Copyright 2006, Graco Inc. All Graco manufacturing locations are registered to ISO 9001.

www.graco.com
Revised August 2013