

# Reactor<sup>®</sup> E-10hp

332144A  
EN

For spraying or dispensing polyurea coatings and polyurethane foam. For professional use only.

Not approved for use in explosive atmospheres or hazardous locations.

*3000 psi (21 MPa, 207 bar) Maximum Working Pressure*



## Important Safety Instructions

Read all warnings and instructions in this manual. Save these instructions.

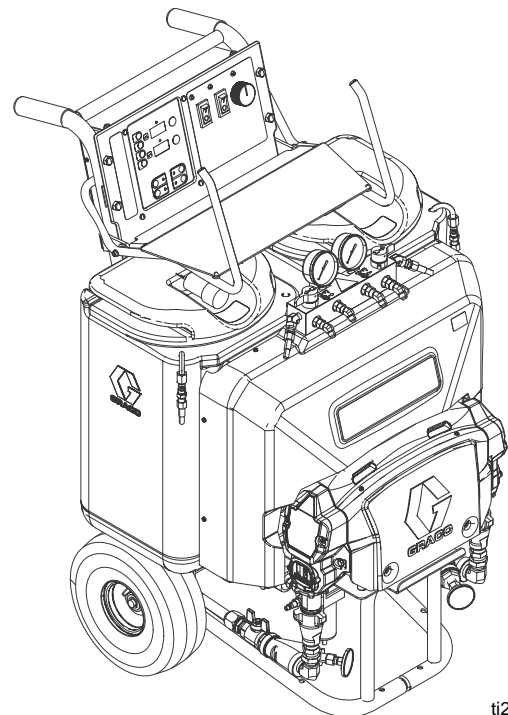









ti21488a

# Contents



<b>Warnings</b> .....	<b>3</b>	<b>Troubleshooting</b> .....	<b>27</b>
<b>Important Isocyanate (ISO) Information</b> .....	<b>6</b>	Pump Control Status Codes .....	27
Isocyanate Conditions .....	6	DIP Switch Settings .....	30
Material Self-ignition .....	6	Heat Control Diagnostic Codes .....	32
Keep Components ISO and RES Separate .....	6	Reactor Electronics .....	34
Moisture Sensitivity of Isocyanates .....	6	Heaters .....	36
Foam Resins with 245 fa Blowing Agents .....	6	Proportioner .....	37
Changing Materials .....	7	<b>Repair</b> .....	<b>40</b>
<b>Systems</b> .....	<b>8</b>	Before Beginning Repair .....	40
<b>Models</b> .....	<b>8</b>	Remove Supply Tank .....	40
<b>Related Manuals</b> .....	<b>9</b>	Replace Recirc/Spray Valves .....	41
<b>Overview</b> .....	<b>10</b>	Displacement Pump .....	42
<b>Component Identification</b> .....	<b>11</b>	Control Panel .....	43
<b>Controls and Indicators</b> .....	<b>12</b>	Motor Control .....	45
Heater Controls .....	12	Heater .....	49
System Controls .....	12	Pressure Transducers .....	51
Controls and Indicators .....	13	Drive Housing .....	52
<b>Setup</b> .....	<b>15</b>	Replace Cycle Counter Switch .....	53
Locate Reactor .....	15	Electric Motor .....	54
Electrical Requirements .....	15	Motor Brushes .....	55
Ground System .....	16	Fans .....	55
Connect Fluid Hoses .....	16	Tank Fluid Level Sensors .....	56
Connect Gun Air Hose .....	16	<b>Parts</b> .....	<b>58</b>
Connect Main Air Supply .....	16	System Packages .....	58
Flush Before First Use .....	16	E-10hp Proportioners .....	59
Fill Wet-Cups .....	17	24T954, 120 V and 230 V Bare Proportioner ..	66
Fill Fluid Tanks .....	17	24U009, 120 V Heater	
Purge Air and Flush Fluid From Lines .....	18	24T955, 230 V Heater .....	68
<b>Startup</b> .....	<b>19</b>	24T962, Display .....	69
Heatup Guidelines .....	20	Fluid Inlets .....	70
Heat Management Tips .....	20	24T960, Fluid Manifold .....	71
<b>Spraying</b> .....	<b>21</b>	25R000, Insulated Hose Bundle with Recirculation	
<b>Pause</b> .....	<b>22</b>	Lines .....	72
<b>Refill Tanks</b> .....	<b>22</b>	Outlet Manifold .....	72
<b>Pressure Relief Procedure</b> .....	<b>23</b>	<b>Electrical Wiring Identification</b> .....	<b>73</b>
<b>Shutdown</b> .....	<b>23</b>	Power Harness .....	73
<b>Maintenance</b> .....	<b>24</b>	Cable and Wire Identification .....	75
<b>Flushing</b> .....	<b>25</b>	<b>Suggested Replacement Parts</b> .....	<b>78</b>
Purge Hoses .....	26	<b>Accessories</b> .....	<b>78</b>
		<b>Dimensions</b> .....	<b>78</b>
		<b>Technical Data</b> .....	<b>79</b>
		<b>Graco Standard Warranty</b> .....	<b>82</b>

# Warnings

The following warnings are for the setup, use, grounding, maintenance, and repair of this equipment. The exclamation point symbol alerts you to a general warning and the hazard symbols refer to procedure-specific risks. When these symbols appear in the body of this manual or on warning labels, refer back to these Warnings. Product-specific hazard symbols and warnings not covered in this section may appear throughout the body of this manual where applicable.



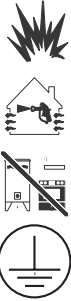

 <h2 style="margin: 0;">WARNING</h2>	
  	<p><b>ELECTRIC SHOCK HAZARD</b></p> <p>This equipment must be grounded. Improper grounding, setup, or usage of the system can cause electric shock.</p> <ul style="list-style-type: none"> <li>• Turn off and disconnect power cord before servicing equipment.</li> <li>• Connect only to grounded electrical outlets.</li> <li>• Use only 3-wire extension cords.</li> <li>• Ensure ground prongs are intact on power and extension cords.</li> <li>• Do not expose to rain. Store indoors.</li> </ul>
	<p><b>TOXIC FLUID OR FUMES HAZARD</b></p> <p>Toxic fluids or fumes can cause serious injury or death if splashed in the eyes or on skin, inhaled, or swallowed.</p> <ul style="list-style-type: none"> <li>• Read MSDSs to know the specific hazards of the fluids you are using.</li> <li>• Store hazardous fluid in approved containers, and dispose of it according to applicable guidelines.</li> </ul>
	<p><b>PERSONAL PROTECTIVE EQUIPMENT</b></p> <p>Wear appropriate protective equipment when in the work area to help prevent serious injury, including eye injury, hearing loss, inhalation of toxic fumes, and burns. This protective equipment includes but is not limited to:</p> <ul style="list-style-type: none"> <li>• Protective eyewear, and hearing protection.</li> <li>• Respirators, protective clothing, and gloves as recommended by the fluid and solvent manufacturer.</li> </ul>
  	<p><b>SKIN INJECTION HAZARD</b></p> <p>High-pressure fluid from gun, hose leaks, or ruptured components will pierce skin. This may look like just a cut, but it is a serious injury that can result in amputation. <b>Get immediate surgical treatment.</b></p> <ul style="list-style-type: none"> <li>• Engage trigger lock when not spraying.</li> <li>• Do not point gun at anyone or at any part of the body.</li> <li>• Do not put your hand over the spray tip.</li> <li>• Do not stop or deflect leaks with your hand, body, glove, or rag.</li> <li>• Follow the <b>Pressure Relief Procedure</b> when you stop spraying and before cleaning, checking, or servicing equipment.</li> <li>• Tighten all fluid connections before operating the equipment.</li> <li>• Check hoses and couplings daily. Replace worn or damaged parts immediately.</li> </ul>

# **WARNING**

	<p><b>FIRE AND EXPLOSION HAZARD</b></p> <p>Flammable fumes, such as solvent and paint fumes, in <b>work area</b> can ignite or explode. To help prevent fire and explosion:</p> <ul style="list-style-type: none"> <li>• Use equipment only in well ventilated area.</li> <li>• Eliminate all ignition sources; such as pilot lights, cigarettes, portable electric lamps, and plastic drop cloths (potential static arc).</li> <li>• Keep work area free of debris, including solvent, rags and gasoline.</li> <li>• Do not plug or unplug power cords, or turn power or light switches on or off when flammable fumes are present.</li> <li>• Ground all equipment in the work area. See <b>Grounding</b> instructions.</li> <li>• Use only grounded hoses.</li> <li>• Hold gun firmly to side of grounded pail when triggering into pail. Do not use pail liners unless they are antistatic or conductive.</li> <li>• <b>Stop operation immediately</b> if static sparking occurs or you feel a shock. Do not use equipment until you identify and correct the problem.</li> <li>• Keep a working fire extinguisher in the work area.</li> </ul>
	<p><b>THERMAL EXPANSION HAZARD</b></p> <p>Fluids subjected to heat in confined spaces, including hoses, can create a rapid rise in pressure due to the thermal expansion. Over-pressurization can result in equipment rupture and serious injury.</p> <ul style="list-style-type: none"> <li>• Open a valve to relieve the fluid expansion during heating.</li> <li>• Replace hoses proactively at regular intervals based on your operating conditions.</li> </ul>
	<p><b>PRESSURIZED ALUMINUM PARTS HAZARD</b></p> <p>Use of fluids that are incompatible with aluminum in pressurized equipment can cause serious chemical reaction and equipment rupture. Failure to follow this warning can result in death, serious injury, or property damage.</p> <ul style="list-style-type: none"> <li>• Do not use 1,1,1-trichloroethane, methylene chloride, other halogenated hydrocarbon solvents or fluids containing such solvents.</li> <li>• Many other fluids may contain chemicals that can react with aluminum. Contact your material supplier for compatibility.</li> </ul>



# WARNING

 	<p><b>EQUIPMENT MISUSE HAZARD</b></p> <p>Misuse can cause death or serious injury.</p> <ul style="list-style-type: none"> <li>• Do not operate the unit when fatigued or under the influence of drugs or alcohol.</li> <li>• Do not exceed the maximum working pressure or temperature rating of the lowest rated system component. See <b>Technical Data</b> in all equipment manuals.</li> <li>• Use fluids and solvents that are compatible with equipment wetted parts. See Technical Data in all equipment manuals. Read fluid and solvent manufacturer's warnings. For complete information about your material, request MSDS from distributor or retailer.</li> <li>• Do not leave the work area while equipment is energized or under pressure.</li> <li>• Turn off all equipment and follow the <b>Pressure Relief Procedure</b> when equipment is not in use.</li> <li>• Check equipment daily. Repair or replace worn or damaged parts immediately with genuine manufacturer's replacement parts only.</li> <li>• Do not alter or modify equipment. Alterations or modifications may void agency approvals and create safety hazards.</li> <li>• Make sure all equipment is rated and approved for the environment in which you are using it.</li> <li>• Use equipment only for its intended purpose. Call your distributor for information.</li> <li>• Route hoses and cables away from traffic areas, sharp edges, moving parts, and hot surfaces.</li> <li>• Do not kink or over bend hoses or use hoses to pull equipment.</li> <li>• Keep children and animals away from work area.</li> <li>• Comply with all applicable safety regulations.</li> </ul>
 	<p><b>MOVING PARTS HAZARD</b></p> <p>Moving parts can pinch, cut or amputate fingers and other body parts.</p> <ul style="list-style-type: none"> <li>• Keep clear of moving parts.</li> <li>• Do not operate equipment with protective guards or covers removed.</li> <li>• Pressurized equipment can start without warning. Before checking, moving, or servicing equipment, follow the <b>Pressure Relief Procedure</b> and disconnect all power sources.</li> </ul>
	<p><b>BURN HAZARD</b></p> <p>Equipment surfaces and fluid that's heated can become very hot during operation. To avoid severe burns:</p> <ul style="list-style-type: none"> <li>• Do not touch hot fluid or equipment.</li> </ul>

# Important Isocyanate (ISO) Information

Isocyanates (ISO) are catalysts used in two component materials.

## Isocyanate Conditions



Spraying or dispensing materials containing isocyanates creates potentially harmful mists, vapors, and atomized particulates.

Read material manufacturer's warnings and material MSDS to know specific hazards and precautions related to isocyanates.

Prevent inhalation of isocyanate mists, vapors, and atomized particulates by providing sufficient ventilation in the work area. If sufficient ventilation is not available, a supplied-air respirator is required for everyone in the work area.

To prevent contact with isocyanates, appropriate personal protective equipment, including chemically impermeable gloves, boots, aprons, and goggles, is also required for everyone in the work area.

## Moisture Sensitivity of Isocyanates

Exposure to moisture (such as humidity) will cause ISO to partially cure; forming small, hard, abrasive crystals, which become suspended in the fluid. Eventually a film will form on the surface and the ISO will begin to gel, increasing in viscosity.

### NOTICE

Partially cured ISO will reduce performance and the life of all wetted parts.

- Always use a sealed container with a desiccant dryer in the vent, or a nitrogen atmosphere. **Never** store ISO in an open container.
- Keep the ISO pump wet cup or reservoir (if installed) filled with appropriate lubricant. The lubricant creates a barrier between the ISO and the atmosphere.
- Use only moisture-proof hoses compatible with ISO.
- Never use reclaimed solvents, which may contain moisture. Always keep solvent containers closed when not in use.
- Always lubricate threaded parts with an appropriate lubricant when reassembling.

## Material Self-ignition

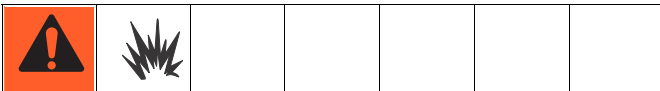

Some materials may become self-igniting if applied too thick. Read material manufacturer's warnings and material MSDS.

**NOTE:** The amount of film formation and rate of crystallization varies depending on the blend of ISO, the humidity, and the temperature.

## Keep Components ISO and RES Separate

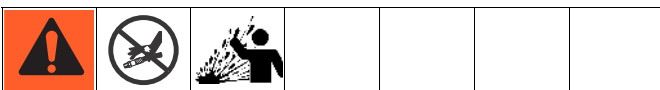

Cross-contamination can result in cured material in fluid lines which could cause serious injury or damage equipment. To prevent cross-contamination:

- **Never** interchange ISO and RES wetted parts.
- Never use solvent on one side if it has been contaminated from the other side.

## Foam Resins with 245 fa Blowing Agents

Some foam blowing agents will froth at temperatures above 90°F (33°C) when not under pressure, especially if agitated. To reduce frothing, minimize preheating in a circulation system.

## Changing Materials

### **NOTICE**

Changing the material types used in your equipment requires special attention to avoid equipment damage and downtime.



- When changing materials, flush the equipment multiple times to ensure it is thoroughly clean.
- Always clean the fluid inlet strainers after flushing.
- Check with your material manufacturer for chemical compatibility.
- When changing between epoxies and urethanes or polyureas, disassemble and clean all fluid components and change hoses. Epoxies often have amines on the RES (hardener) side. Polyureas often have amines on the RES (resin) side

# Systems

Part	Maximum Working Pressure, psi (MPa, bar)	Volts	Proportioner Model	Unheated Hose 35 ft (10.6 m)	Cord Adapter	Gun	
						Model	Part
APT100	3000 (21, 207)	120 V	24T100	25R000	---	Fusion® Air Purge	249810
P2T100	3000 (21, 207)	120 V	24T100	25R000	---	PROBLER® P2	GCP2RA
APT900	3000 (21, 207)	230 V	24R900	25R000	North America	Fusion® Air Purge	249810
APT901	3000 (21, 207)	230 V	24R900	25R000	Europe	Fusion® Air Purge	249810
APT902	3000 (21, 207)	230 V	24R900	25R000	Australia/Asia	Fusion® Air Purge	249810
P2T900	3000 (21, 207)	230 V	24R900	25R000	North America	PROBLER® P2	GCP2RA
P2T901	3000 (21, 207)	230 V	24R900	25R000	Europe	PROBLER® P2	GCP2RA
P2T902	3000 (21, 207)	230 V	24R900	25R000	Australia/Asia	PROBLER® P2	GCP2RA
24T900	3000 (21, 207)	230 V	24R900	---	North America	---	---
24T901	3000 (21, 207)	230 V	24R900	---	Europe	---	---
24T902	3000 (21, 207)	230 V	24R900	---	Australia/Asia	---	---

## Models

The model no., series letter, and serial no. are located on the back of the cart. For faster assistance, please have that information ready before calling Customer Service.

Bare Proportioner Part, Series	Volts	* Electrical Connection	Maximum Working Pressure, psi (MPa, bar)	Approvals
24T100, A	120 V	20 A cord (motor) 20 A cord (heaters)	3000 (21, 207)	  <b>Intertek</b> 9902471 Conforms to ANSI/UL Std. 499 Certified to CAN/CSA Std. C22.2 No. 88
24R900, A	230 V	15 A cord (motor) 15 A cord (heaters)	3000 (21, 207)	

\* See page 15 for detailed electrical requirements.



# Related Manuals

The following manuals are for Reactor E-10hp components and accessories. Some are supplied with your package, depending on its configuration. Manuals are also available at [www.graco.com](http://www.graco.com).

<b>Displacement Pump</b>	
<b>Part No.</b>	<b>Description</b>
311076	Instruction-Parts Manual (English)
<b>Fusion Air Purge Spray Gun</b>	
<b>Part No.</b>	<b>Description</b>
309550	Instruction-Parts Manual (English)
<b>Probler P2 Spray Gun</b>	
<b>Part No.</b>	<b>Description</b>
313213	Instruction-Parts Manual (English)
<b>Probler P2 Recirculation Kit</b>	
<b>Part No.</b>	<b>Description</b>
406842	Instruction-Parts Manual (English)

# Overview

The Reactor E-10hp is a portable, electric-powered, 1:1 mix ratio proportioner for use with:

- Polyurea
- Polyurea hybrid coatings
- Polyurethane foam

Material may be applied with impingement mix spray guns.

The Reactor E-10hp is gravity-fed from 6 gal. (22.7 liter) supply tanks mounted on the unit.

Severe duty, positive displacement reciprocating piston pumps meter fluid flow to the gun for mixing and applying. When set to recirculation mode, Reactor E-10hp will circulate fluids back to the supply tanks.

The Reactor E-10hp uses primary heating rods and boost heating rods, for each fluid, and an insulated hose bundle with circulation return hoses. This allows the hoses and gun to be preheated to the desired temperature before spraying. The boost heating rods are used during circulation mode to reduce heatup time. Digital displays show the temperatures of the two fluids.

Electronic controls monitor fluid pressures, drive the motor, and alerts the operator if errors occur. See **Motor/Pump Status Codes**, page 14, for further information.

The Reactor E-10hp has two recirculation speeds, slow and fast, and an adjustable pressure output.

## Slow Recirculation

- Slow circulation results in a higher temperature transfer in the heater, so hoses and gun heat up quicker.
- Good for touchup or low flow spraying, up to moderate temperature.
- Not used to circulate full tanks up to temperature.
- Use with 245 fa blowing agent foams, to minimize heat returned to tank and reduce frothing.

## Fast Recirculation

- Use to support higher flow rates or higher temperatures by preheating the tanks.
- Agitates fluid within tanks, to avoid heating only the fluid at the top of the tank.
- Use for flushing.

## Pressure Adjust

Automatically maintains selected pressure output for dispensing or spraying.

# Component Identification

## Key for FIG. 1

- |   |   |   |  |
|---|---|---|--|
| A | Supply Tank (ISO)   | N | Desiccant Dryer  |
| B | Supply Tank (RES)   | P | Recirculation Tubes  |
| C | Pump (ISO)  | Q | Air Line Inlet (quick-disconnect fitting)                            |
| D | Pump (RES)  | R | Outlet Hose Connections  |
| E | Heater (under shroud)                                     | S | Return Hose Connections  |
| F | Fluid Pressure Gauges                                     | T | Fluid Temperature Sensors (located on heater assembly, under shroud) |
| G | Recirc/Spray and Overpressure Relief Valves               | U | Hose Rack and Control Shield   |
| H | Tank Level Sensors (bottom of tanks)                      | V | Fluid Inlet Ball Valves (each side)                                  |
| J | Control Panel; see FIG. 2, page 12                        | W | Fluid Inlet Strainers (each side)                                    |
| K | Electric Motor and Drive Housings                         | X | Power Cords (not shown)  |
| L | Insulated Hose Bundle (includes circulation return hoses) | Y | Fluid Temperature Gauges (each side)                                 |
| M | Fusion Air Purge Spray Gun                                | Z | Air Filter/Moisture Separator  |

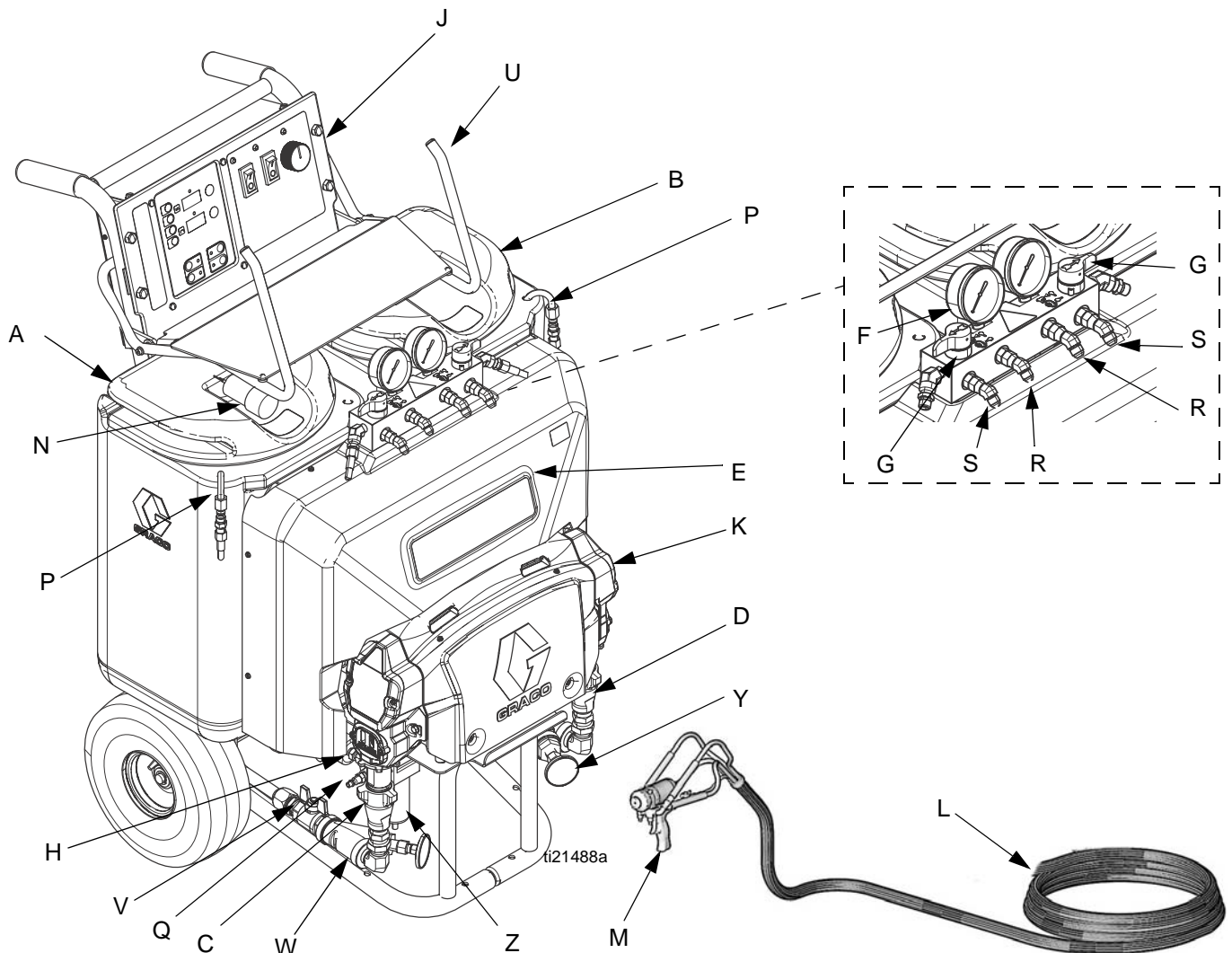

FIG. 1: Component Identification

# Controls and Indicators

See **Controls and Indicators** identification table, page 13.

**NOTICE**  
To prevent damage to soft key buttons, do not press the buttons with sharp objects such as pens, plastic cards, or fingernails.

## Heater Controls

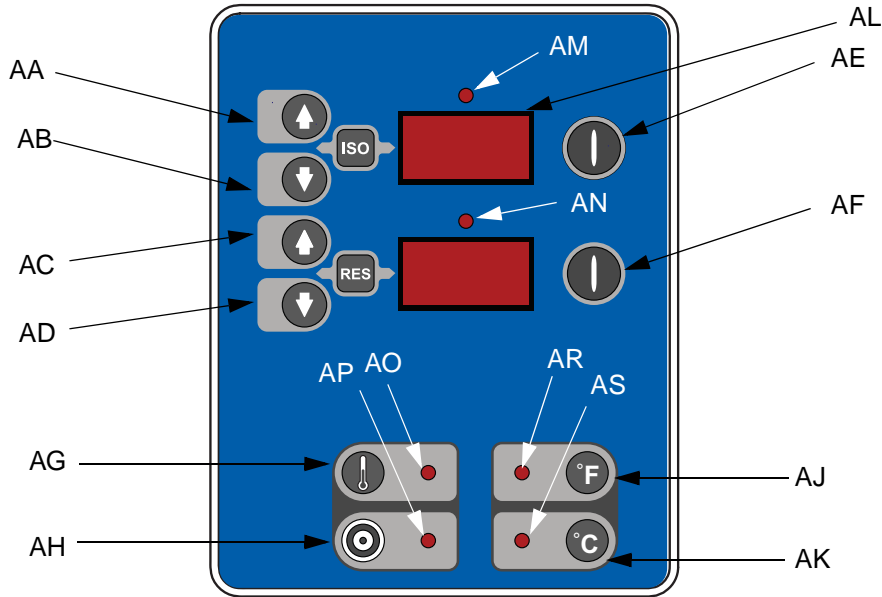

FIG. 2. Heater Controls and Indicators

## System Controls

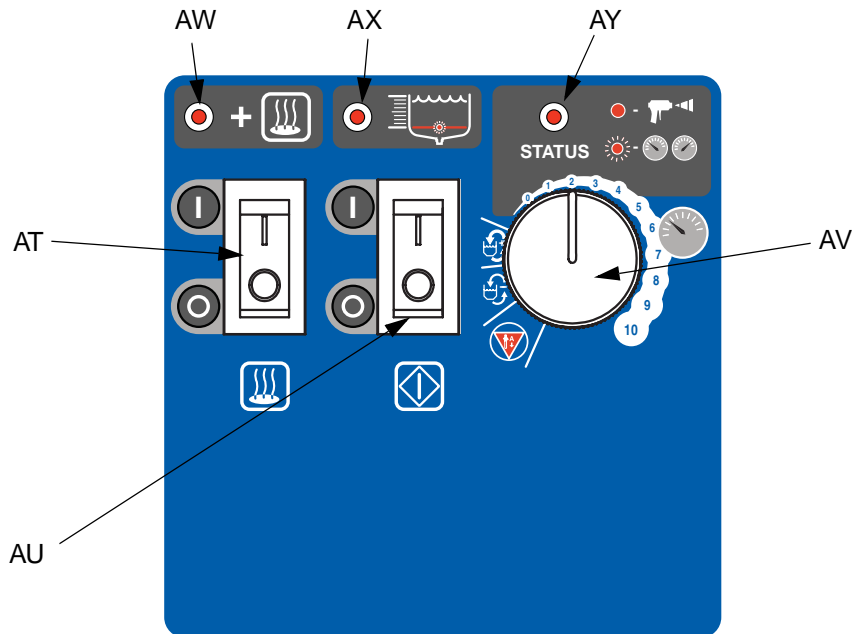





FIG. 3. System Controls and Indicators

## Controls and Indicators

Key	Name	Description
<b>Heater Controls</b>		
AA	ISO Setpoint Increase	Increases the temperature setpoint by one degree in the units selected within the setpoint limits. Press target key prior to adjusting.
AB	ISO Setpoint Decrease	Decreases the temperature setpoint by one degree in the units selected within the setpoint limits. Press target key prior to adjusting.
AC	RES Setpoint Increase	Increases the temperature setpoint by one degree in the units selected within the setpoint limits. Press target key prior to adjusting.
AD	RES Setpoint Decrease	Decreases the temperature setpoint by one degree in the units selected within the setpoint limits. Press target key prior to adjusting.
AE	ISO Heater On/Off Key	Turns heater on or off for ISO zone. Also clears heater zone diagnostic codes, see page 32.
AF	RES Heater On/Off Key	Turns heater on or off for RES zone. Also clears heater zone diagnostic codes, see page 32.
AG	Actual Temperature Key	Press to display actual temperature. Press and hold to display electrical current.
AH	Target Temperature Key	Press to display target temperature. Press and hold to display heater control circuit board temperature.
AJ	Temperature Scale Key °F	Press to change temperature scale to degrees Fahrenheit.
AK	Temperature Scale Key °C	Press to change temperature scale to degrees Celsius.
AL	Temperature Display	Show actual temperature or target temperature of heater zones, depending on selected mode. Defaults to actual at startup. Range is 32-170°F (0-77°C) for ISO and RES.
<b>Heater Indicators</b>		
AM	ISO Heater Activity	LEDs flash when heater zones are on. The duration of each flash shows the extent that the heater is turned on.
AN	RES Heater Activity	LEDs flash when heater zones are on. The duration of each flash shows the extent that the heater is turned on.
AO	Actual Temperatures Active	Actual temperatures are displayed.
AP	Target Temperatures Active	Target temperatures are displayed.
AR	Fahrenheit Units Active	Indicates that temperatures are displayed in °F.
AS	Celsius Units Active	Indicates that temperatures are displayed in °C.
<b>System Controls</b>		
AT	Heater Power	Enables heater control. The switch includes a 20 A circuit breaker.
AU	Motor Power	Enables motor. The switch includes a 20 A circuit breaker.
AV	Motor Pump Control Function Knob	Selects operation mode / pressure setpoint. See <b>Motor/Pump Control Function Knob</b> , page 14.
<b>System Indicators</b>		
AW	Boost Heat Indicator	Indicates boost heat is active.
AX	Tank Level Indicator	See <b>Tank Level Sensor LED</b> , page 14.
AY	System Status Indicator	Flashes an error code if alarm or deviation is active. See <b>Motor/Pump Status Codes</b> , page 14.

### Motor/Pump Control Function Knob

Use knob (AV) to select desired function.

Icon	Setting	Function
	Stop/Park	Stops motor and automatically parks pumps.
	Slow Recirc	Slow recirculation speed.
	Fast Recirc	Fast recirculation speed.
	Pressure Adjust	Adjusts fluid pressure to gun in spray mode.

### Motor/Pump Status Codes

If error occurs, status indicator (AY) will blink 1 to 19 times to indicate status code, pause, then repeat, or will blink other active error codes. See TABLE 1 for a brief description of status codes.

**Table 1: Motor/Pump Status Codes**

No.	Name
1	Pressure imbalance between ISO and RES sides
2	Pressure deviation from setpoint
3	Pressure transducer ISO failure
4	Pressure transducer RES failure
5	Excessive current draw
6	High motor temperature
7	No cycle counter switch input
8	High cycle rate deviation (more than 1.0 GPM)
	High cycle rate shutdown (more than 1.1 GPM)
9	Low tank level
10	Not used
11	Not used
12	Motor controller bus overvoltage
13	Motor controller bus undervoltage
14	Motor controller high temperature
15-19	Motor controller fault

**NOTE:** The default is to shut down if a status code indication occurs.

### Heater Control Diagnostic Codes

Heater control diagnostic codes appear on the temperature display. These alarms turn off heat.

**Table 2: Heater Control Diagnostic Codes**

Code	Name	Alarm Zone
01	High fluid temperature	Individual
02	High zone current	Individual
03	No zone current with heater on	Individual
04	Thermocouple not connected	Individual
05	High controller temperature	Individual
06	No communications with zone pod	Individual
09	Display is missing	Individual
99	No communication with heater control module	Individual

### Tank Level Sensor LED

The tank level sensor LED (AX) is triggered when chemical is not present in either tank.

**Table 3: Tank Level Indicator (AX)**

Chemical	Status
> 1 gallon	Off
< 1 gallon	Flashing

# Setup

## Locate Reactor

1. Locate Reactor on a level surface.
2. Do not expose Reactor to rain.

To avoid electric shock, always unplug both cords before servicing Reactor and wait one minute.					

## Electrical Requirements



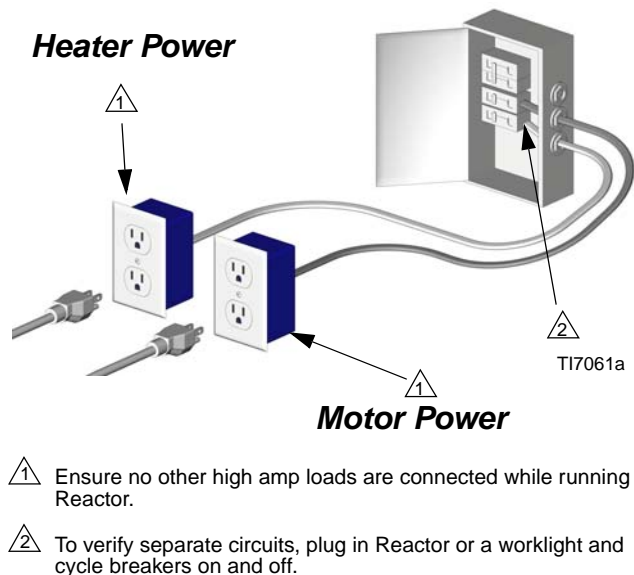

Improper wiring may cause electric shock or other serious injury if work is not performed properly. All electrical wiring must be done by a qualified electrician and comply with all local codes and regulations.					

1. Connect Reactor to the correct power source for your model. See *Table 4*. Power cords must be connected to two separate, dedicated circuits. See FIG. 4.
2. Some models include cord adapters for use outside North America. Connect the appropriate adapter to the unit's power cord before connecting to your power source.



**FIG. 4: Use Two Separate Circuits**

**Table 4: Electrical Requirements**





Model	Required Power Source	Power Cord Connectors	Supplied Local Adapters
230 V, 1 phase, 50/60 Hz, two 15 ft (4.5 m) power cords	Two separate, dedicated circuits rated at minimum of 15 A each	 Two IEC 3-20 C20 Plugs	 NEMA 6-15P (North America)  Euro CEE74 (Europe)  YP-39 AS3112 (Australia/Asia)
120V, 50/60 Hz, two 15 ft (4.5 m) power cords	Two separate dedicated circuits rated at minimum of 20 A each	 Two NEMA 5-20P Plugs	

**Table 5: Extension Cord Requirements**

Model	Required Wire Size	
	Up to 50 ft (15 m)	Up to 100 ft (30 m)
All models	AWG 12	AWG 10

**NOTE:** Cords must be 3-conductor grounded, rated for your environment.

## Ground System

						
---	---	---	---	--	--	--

The equipment must be grounded to reduce the risk of static sparking and electric shock. Electric or static sparking can cause fumes to ignite or explode. Improper grounding can cause electric shock. Grounding provides an escape wire for the electric current.

**Reactor:** grounded through power cord.

**Generator (if used):** follow your local code. Start and stop generator with power cord(s) disconnected.

**Spray gun:** grounded through the supplied fluid hoses, connected to a properly grounded Reactor. Do not operate without at least one grounded fluid hose.

**Object being sprayed:** follow your local code.

**Solvent pails used when flushing:** follow your local code. Use only metal pails, which are conductive, placed on a grounded surface. Do not place pail on a nonconductive surface, such as paper, plastic, or cardboard, which interrupts grounding continuity.

**To maintain grounding continuity when flushing or relieving pressure:** hold a metal part of spray gun firmly to the side of a grounded *metal* pail, then trigger gun.

## Connect Fluid Hoses

1. Connect fluid supply hoses to outlet hose connections (R, FIG. 5). Red hoses for ISO, blue for RES. Fittings are sized to prevent connection errors. Connect other end of hoses to ISO and RES inputs of gun.

**NOTE:** Probler guns use recirc accessory kit 24E727.

2. Connect recirculation hoses from gun recirculation ports to connections (S).

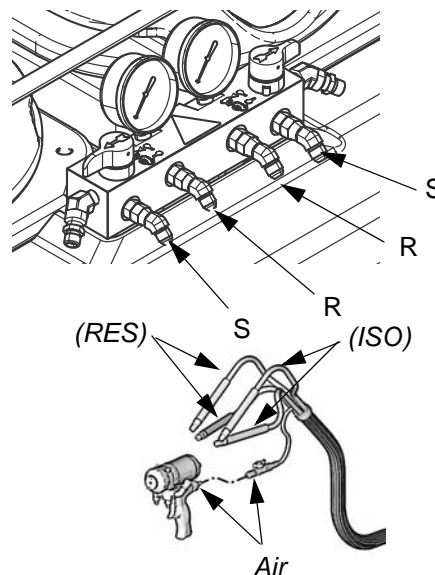

FIG. 5

## Connect Gun Air Hose

1. Connect gun air hose to the gun air input and to the air filter outlet (Z). If you are using more than one hose bundle, join the air hoses with the nipple provided with the hose bundle.
2. On units with Fusion guns, connect the supplied ball valve and quick-disconnect coupler to the gun air hose, then connect the coupler to the gun air fitting.

## Connect Main Air Supply

Connect the main air supply to the quick disconnect fitting (Q) on the unit. Air supply hose must be at least 5/16 in. (8 mm) ID up to 50 ft (15 m) or 3/8 in. (10 mm) ID up to 100 ft (30 m).

**NOTE:** Air Filter/Moisture Separator (Z) is equipped with an automatic moisture drain.

## Flush Before First Use

The Reactor is tested with a plasticizer oil at the factory. Flush out the oil with a compatible solvent before spraying. See **Flushing**, page 25.



## Fill Wet-Cups

Keep the felt washers in the pump wet-cups saturated with Graco ISO pump oil, Part No. 217374. The lubricant creates a barrier between the ISO and the atmosphere.

<p>Pump rod and connecting rod move during operation. Moving parts can cause serious injury such as pinching or amputation. Keep hands and fingers away from wet-cup during operation. Shut off Motor Power  before filling wet-cup.</p>						

Fill wet-cups through slots in plate, or loosen screws and swing plate aside.

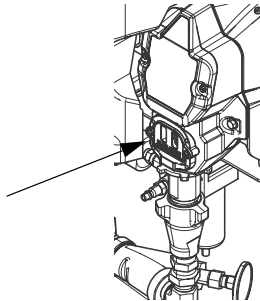

## Fill Fluid Tanks

--	--	--	--	--	--	--

### NOTICE

To prevent cross-contamination of fluids and equipment parts, **never** interchange (isocyanate) and (resin) parts or containers.

Have at least two 5 gal. (19 liter) pails to transfer fluid from drums to supply tanks. Label one pail "ISO" and the other "RES", using the red and blue labels provided. Always double-check which material you have before pouring it in the supply tanks. Pouring is easier if pails are not filled to the top.

Open only one supply tank at a time, to avoid splashing material from one tank into the other when filling.

**NOTE:** Using a drill and mixing blade, mix filled or separated materials in the pail before adding to the tanks. Material left in the tanks overnight may need to be remixed in the tanks.

1. Lift hose rack. Remove tank cover and pour ISO into tank (red side, with desiccant filter in cover).

Replace cover

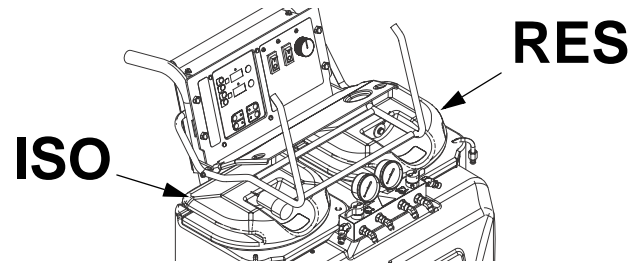

Add thin coating of grease lubricant to tank o-ring if lid is difficult to assemble to tank.

**NOTE:** Desiccant filter is blue when fresh, and turns pink when saturated. Be sure shipping plugs are removed from openings on desiccant filter.

2. Remove tank cover and pour resin into RES tank (blue side). Replace cover

# Purge Air and Flush Fluid From Lines

<p>To avoid fire and explosion:</p> <ul style="list-style-type: none"> <li>• Flush equipment only in a well-ventilated area.</li> <li>• Ensure main power is off and heater is cool before flushing.</li> <li>• Do not turn on heater until fluid lines are clear of solvent.</li> </ul>						

1. Remove both recirculation tubes (P) from the tanks and secure each one in a dedicated waste container.

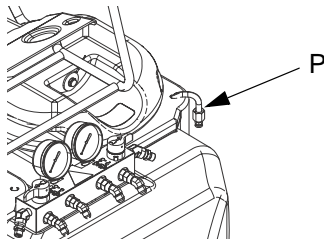

2. Set function knob to Stop/Park

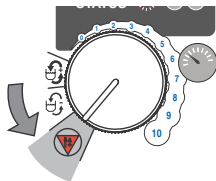

3. Plug in power cord(s). See Table 2, page 15.
4. Open both pump fluid inlet valves (V, shown in open position).

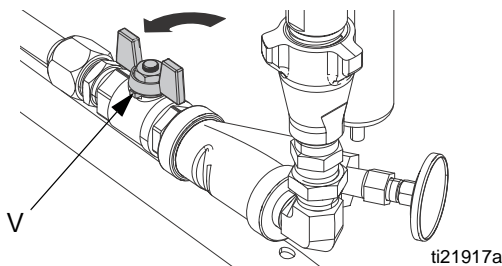

5. Turn on Motor Power. System status indicator (AY) should turn on.

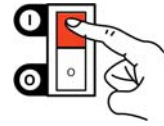

6. Set Recirc/Spray valves to Recirc.

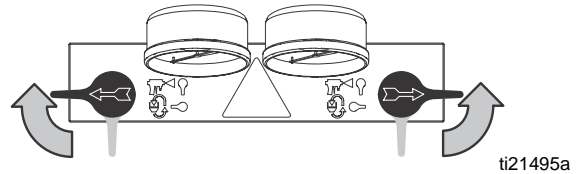

7. Set function knob to Slow Recirc or Fast Recirc

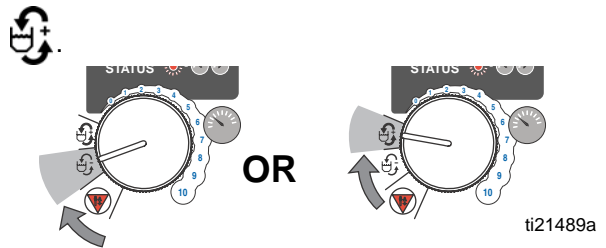

8. When clean fluids exit both recirculation tubes (P), set function knob to Stop/Park

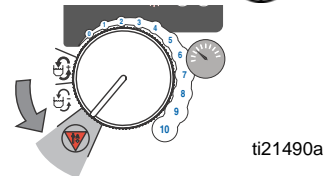

9. Replace recirculation tubes in supply tanks.

# Startup

<p>Heated fluid can cause equipment surfaces to become very hot. To avoid severe burns:</p> <ul style="list-style-type: none"> <li>Do not operate Reactor without all covers and shrouds in place.</li> <li>Do not touch hot fluid or equipment.</li> <li>Allow equipment to cool completely before touching it.</li> </ul>						

1. Perform **Setup**, page 15.
2. Set function knob to Slow Recirc or Fast Recirc . See **Heatup Guidelines**, page 20, then continue with steps 3-6.

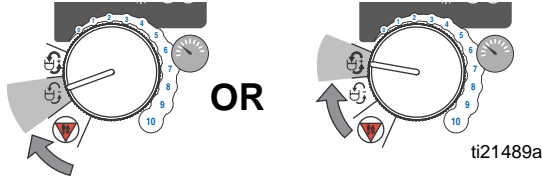

3. Turn on Heater Power.

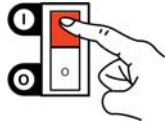

4. Set temperatures:
  - a. Press or to change temperature scale.
  - b. Press to display target temperatures.
  - c. To set **ISO** heat zone target temperature, press or until display shows desired temperature. Repeat for **RES** zone.

- d. Press to display actual temperatures.

5. Circulate through heater until temperature readouts display desired temperature. See Table 6.
6. Adjust heat controls as necessary for a stable spray temperature.

**Table 6: Approximate heatup time for starting a cold machine with 5 gallons (19 liters) per side**

Fluid Spray Target Temperature	120 V	230 V
		35 ft (10.7 m) Hose (1 bundle)
125°F (52°C)	15 minutes	10 minutes
170°F (77°C)	40 minutes	20 minutes

**NOTE:** Heatup times are based on 70°F (21°C) starting material temperature and 70°F (21°C) ambient temperature.

**NOTE:** Different fluids will absorb heat at different rates. When refilling a warm machine, heatup times will be less.

## Heatup Guidelines

The fluids must be circulated from the pumps through the heater, hoses, and back to the tanks to ensure warm fluids are supplied to the gun.

### Slow Recirculation

- Slow Recirc results in a higher temperature transfer in the heater, so hoses and gun heat up quicker.
- Good for touchup or low flow spraying, up to moderate temperature.

### Fast Recirculation

Fast Recirc keeps heaters on full-time to bring fluid tanks up to temperature. The higher your flow rate, the more heat needed in the tanks before spraying.

- *For 230 V systems:* Use Fast Recirc until pump inlet fluid temperature gauges (Y) are within 45°F (25°C) of target outlet temperature.
- *For 120 V systems:* Use Fast Recirc until pump inlet fluid temperature gauges (Y) are within 30°F (17°C) of target temperature.
- *Volume in tanks:* Use only what you need. For example, 2.5 gal. (10 l) in each tank will heat up almost twice as fast as 5 gal. (20 l).
- Mixes fluid within tanks, to avoid heating only the fluid at the top of the tank.
- Use for flushing.

## Heat Management Tips

- Heaters perform better with lower flow rates or smaller mix modules.
- Triggering the gun for short periods helps maintain efficient heat transfer, keeping material at the desired temperature. Triggering the gun for a long period may not allow enough heating time, depending on material temperature in tanks.
- If temperature displays fall below acceptable limits, set function knob to Slow Recirculation  and circulate again to bring temperatures back up.
- Each 35 ft (10.7 m) hose bundle adds about 5 minutes to heatup time, with most materials. Maximum recommended hose length is 105 ft (32 m).
- For a quicker start, do initial heatup circulation with the tanks 1/4 to 1/3 filled, then add more material.

# Spraying



**NOTE:** Air is supplied to spray gun with gun piston safety lock or trigger safety lock engaged and gun fluid manifold valves closed (if present).

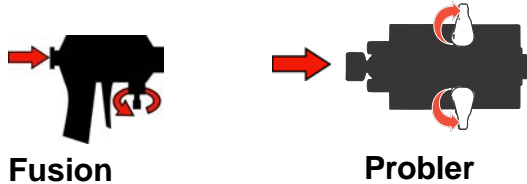

1. Set function knob to Stop/Park . Verify system status indicator LED is on.

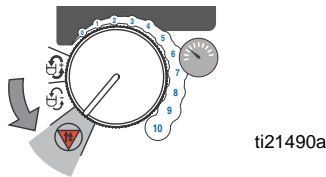

2. Set Recirc/Spray valves to Spray.

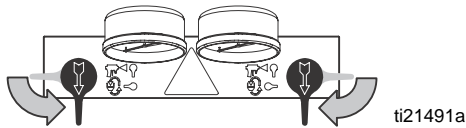

3. Turn function knob to Pressure Adjust . Keep turning to the right until fluid pressure gauges show desired pressure.

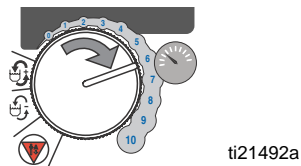

4. Check fluid pressure gauges to ensure proper pressure balance. If imbalanced, reduce pressure of higher component by **slightly** turning Recirc/Spray valve for that component toward Recirc, until gauges show balanced pressures. The pressure imbalance alarm (Status Code 1) is inactive for 10 seconds after entering spray pressure mode, to allow time to balance pressures.

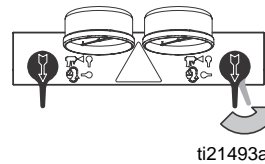

*In this example, RES side pressure is higher, so use the RES side valve to balance pressures.*

**NOTE:** Watch gauges for 10 seconds to be sure pressure holds on both sides and pumps are not moving.

5. Open gun fluid manifold valves (impingement mix guns only).

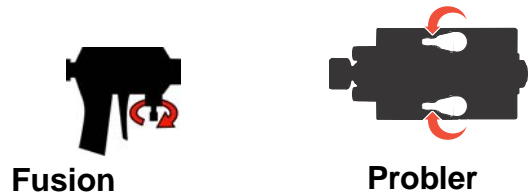

**NOTE:** On impingement guns, never open fluid manifold valves or trigger gun if pressure are imbalanced.

6. Disengage piston safety lock or trigger safety lock.

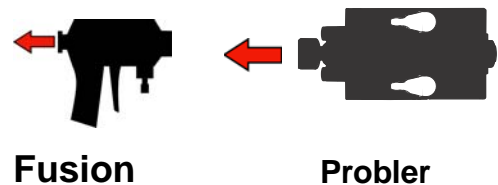

7. Test spray onto cardboard or plastic sheet. Verify that material fully cures in the required length of time, and is the correct color. Adjust pressure and temperature to get desired results. Equipment is ready to spray.

# Pause

To bring the hose and gun back to spray temperature after a brief break, use the following procedure.

1. Engage piston safety lock or trigger safety lock.



Fusion

Probler

2. Set function knob to Slow Recirc .

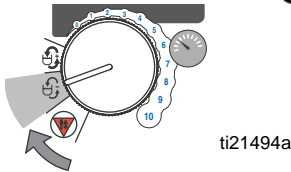

3. Set Recirc/Spray valves to Recirc until temperature readouts come back up.

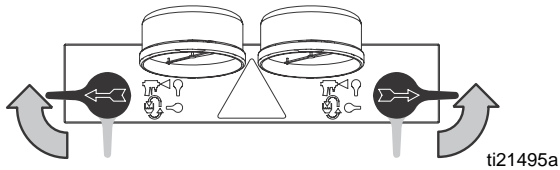

4. If you stop spraying for more than 2 minutes when using an impingement mix gun, close gun fluid valves. Doing this will keep the internal parts of the gun cleaner and prevent crossover.



Fusion

Probler

# Refill Tanks

Material can be added to the tanks at any time. See **Fill Fluid Tanks**, page 17.

**NOTE:** If you are operating at high temperatures or flow rates, follow **Pause** instructions to bring tanks up to temperature.

NOTICE
<p>To prevent cross-contamination of fluids and equipment parts, <b>never</b> interchange ISO and RES parts or containers.</p> <p>Have at least two 5 gal. (19 liter) pails to transfer fluid from drums to supply tanks. Label one pail "ISO" and the other "RES", using the red and blue labels provided. Always double-check which material you have before pouring it in the supply tanks. Pouring is easier if pails are not filled to the top.</p> <p>Open only one supply tank at a time, to avoid splashing material from one tank into the other when filling.</p>

# Pressure Relief Procedure



Follow the Pressure Relief Procedure whenever you see this symbol.



This equipment stays pressurized until pressure is manually relieved. To help prevent serious injury from pressurized fluid, such as skin injection, splashing fluid and moving parts, follow the Pressure Relief Procedure when you stop spraying and before cleaning, checking, or servicing the equipment.

1. Engage piston safety lock or trigger safety lock.



**Fusion**

**Probler**

2. Set function knob to Stop/Park .

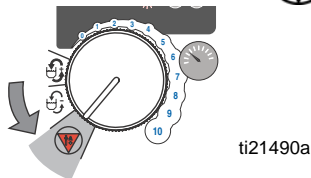

ti21490a

3. Turn Recirc/Spray valves to Recirc. Fluid will be dumped to supply tanks. Pumps will move to the bottom of their stroke. Ensure gauges drop to 0.

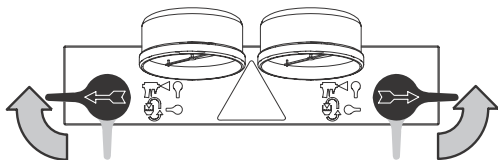

ti21495a

# Shutdown

**NOTE:** For longer breaks (more than 10 minutes) use the following procedure. If you will be shutdown for more than 3 days, first see **Flushing**, page 25.

1. Shut off Heater Power.



2. Shut off Motor Power.



3. Follow all steps of **Pressure Relief Procedure**, page 23.

4. Close gun fluid valves ISO and RES. Doing this will keep the internal parts of the gun cleaner and prevent crossover.



**Fusion**



**Probler**

5. Refer to your separate gun manual and perform **Shutdown** procedure.

# Maintenance

- Check pump wet-cups fluid level daily, page 17.
- Throat u-cup is not adjustable. Do not overtighten packing nut/wet-cup.
- Keep component ISO from exposure to moisture in atmosphere, to prevent crystallization.
- Wipe supply tank lid o-ring, inner rim, and inner tank walls daily to prevent ISO crystallization. Keep film of grease on o-ring and inside of lid.
- Check desiccant filter weekly. Filter is blue when fresh, and turns pink when saturated.
- Remove plug (X) and clean fluid inlet strainer (S) as needed. Always clean the fluid inlet strainers after flushing.

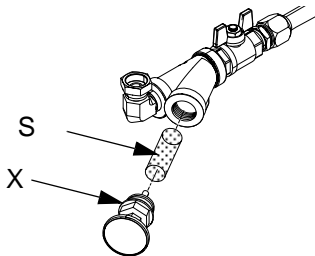

ti21836a

- Generally, flush if you will shutdown for more than three days. Flush more often if material is moisture sensitive and humidity is high in the storage area, or if material may separate or settle out over time.
- *If using an impingement mix gun, close gun fluid valves when not spraying. Doing this will keep the internal parts of the gun cleaner and prevent cross-over. Clean gun mix chamber ports and check valve screens regularly. See gun manual.*



**Fusion**



**Probler**

- *If using an Fusion Air Purge impingement mix gun, always grease the gun after use until purge air carries grease mist out the front of the gun. Use Part No. 117773 Grease. See gun manual.*



# Flushing

<p>To avoid fire and explosion:</p> <ul style="list-style-type: none"> <li>• Flush equipment only in a well-ventilated area.</li> <li>• Ensure main power is off and heater is cool before flushing.</li> <li>• Do not turn on heater until fluid lines are clear of solvent.</li> </ul>						

- Generally, flush if you will be shut down for more than 3 days. Flush more often if material is moisture sensitive and humidity is high in the storage area, or if material may separate or settle out over time.
  - Flush out old fluid with new fluid, or flush out old fluid with a compatible solvent before introducing new fluid.
  - Use the lowest possible pressure when flushing.
  - Always leave some type of fluid in system. Do not use water.
  - For long term storage, flush out the solvent with a storage fluid such as Bayer Mesamoll plasticizer or, at minimum, clean motor oil.
1. Engage piston safety lock or trigger safety lock. Close fluid valves ISO and RES. Leave air on.

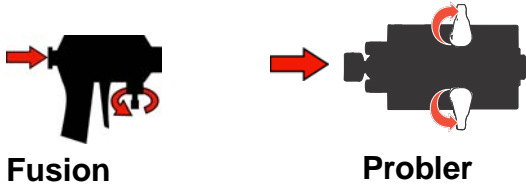

2. Set function knob to Stop/Park

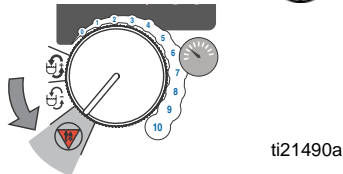

9. Set function knob to Fast Recirc

3. Shut off Heater Power. Allow system to cool.



4. Remove recirculation tubes (P) from supply tanks and place in original containers or waste containers.

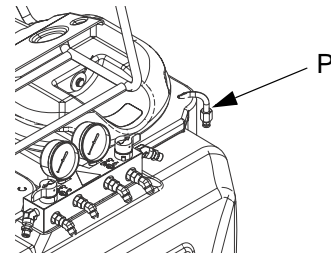

5. Turn Recirc/Spray valves to Recirc.

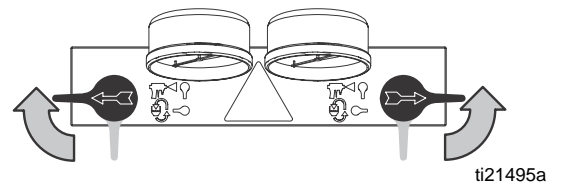

6. Set function knob to Fast Recirc

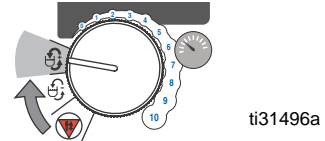

7. Set function knob to Stop/Park

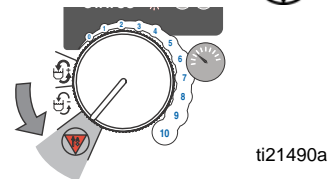

8. Wipe out any remaining material from the supply tanks. Fill each supply tank with 1-2 gal. (3.8-7.6 l) of solvent recommended by your material manufacturer.

through system to waste containers.

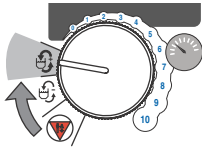

ti31496a

10. When nearly clear solvent comes from recirculation tubes, set function knob to Stop/Park . Return recirculation tubes to supply tanks.

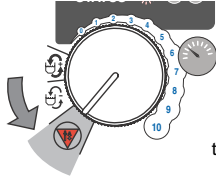

ti21490a

11. Set function knob to Fast Recirc . Circulate solvent through system for 10-20 minutes to ensure thorough cleaning.

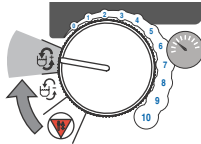

ti31496a



**NOTE:** To flush gun, refer to gun instruction manual.

## Purge Hoses

Disconnect hoses from gun and secure back into the tanks for thorough cleaning with solvent.

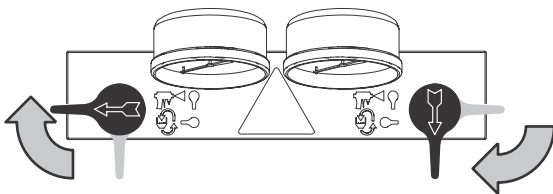
- Turn Recirc/Spray valve ISO to Spray.



- Open gun into waste ISO container.
- Set function knob to Slow Recirc  until hose is flushed.
- Set function knob to Stop/Park .
- Repeat for RES side.

12. Set function knob to Stop/Park .

13. Solvent flushing is a two step process. Go back to step 4, drain solvent, and flush again with fresh solvent.
14. Leave unit filled with solvent, plasticizer, clean motor oil, or refill supply tanks with new material and re-prime.

**NOTE:** Never leave the unit dry unless it has been disassembled and cleaned. If fluid residue dries in the pumps, the ball checks may stick the next time you use the unit.

# Troubleshooting

## Pump Control Status Codes

Determine the status code by counting the number of times the system status indicator blinks. The status indicator will blink 1-19 times to indicate a status code.

Multiple active status codes are separated by a longer duration pause.

### Status Code 1: Pressure Imbalance

**NOTE:** The unit does not check for pressure imbalance at setpoints less than 300 psi (2.1 MPa, 21 bar).

**NOTE:** The unit does not check for pressure imbalance for 10 sec after entering pressure mode.

Unit senses pressure imbalance between components ISO and RES, and warns or shuts down, depending on settings of DIP switches 1 and 2. To turn off automatic shutdown and/or tighten pressure tolerances for status code 1, see **DIP Switch Settings**, page 30.

1. Reduce pressure of higher component by **slightly** turning Recirc/Spray valve for that component toward Recirc, until gauges show balanced pressures.

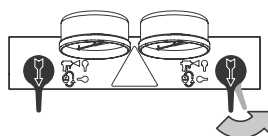

*In this example, RES side pressure is higher, so use the RES side valve to balance pressures.*

2. If pressure imbalance continues, see **Proportioner Troubleshooting**, page 37.

### Status Code 2: Pressure Deviation from Setpoint

**NOTE:** The unit does not check for pressure deviation at setpoint less than 400 psi (2.8 MPa, 28 bar).

Unit senses pressure deviation from setpoint, and warns or shuts down, depending on settings of DIP switches 3 and 4. If equipment cannot maintain enough pressure for a good mix with an impingement mix gun, try using a smaller mix chamber or nozzle.

To turn off automatic shutdown and/or change pressure tolerances for status code 2, see **DIP Switch Settings**, page 30.

Deviation can occur if power is turned on if function knob (AV) is not set to Park/Off. Leave knob in Park/Off mode until status indicator LED turns on.

### Status Code 3: Pressure Transducer ISO Failure

1. Check transducer ISO electrical connection (J11) at board, page 46.
2. Reverse ISO and RES transducer electrical connections at board, page 46. If error moves to transducer RES (Status Code 4), replace transducer ISO, page 51.

### Status Code 4: Pressure Transducer RES failure

1. Check transducer RES electrical connection (J12) at board, page 46.
2. Reverse ISO and RES transducer electrical connections at board, page 46. If error moves to transducer ISO (Status Code 3), replace transducer RES, page 51.

### Status Code 5: Excessive Current Draw

1. Shut off unit and retry operation. Brushes may not be fully seated.
2. Check fan operation. Elevated temperature can cause excessive current draw.
3. Locked rotor; motor unable to turn. Replace motor, page 54.
4. Short on control board. Replace board, page 45.
5. Worn or hung up motor brush causing arcing of brush at commutator. Replace brushes, page 55.
6. Disconnect motor connections from the control board. Cycle power.
  - a. If status code 5 is still present, replace the board.

- b. If status code 5 is not active, test motor. See **Test Motor**, page 54.

### Status Code 6: High Motor Temperature

Motor is running too hot.

1. Reduce pressure duty cycle, gun tip size, or move Reactor to a cooler location. Allow 1 hour for cooling.
2. Check fan operation. Clean fan and motor housing.
3. Check J9 overtemperature connector on control board.

### Status Code 7: No Cycle Counter Switch Input

Have not received input from cycle counter switch for 10 seconds after selecting Recirc mode or unit is unable to park within 15 seconds of entering park mode.

1. Verify that recirc valves are open and unit is set to Recirc mode.
2. Check cycle counter switch connection to board (J10), see FIG. 12, page 46.
3. Check that magnet (224) and cycle counter switch (223) are in place under RES side motor end cover (229). Replace if necessary.

### Status Code 8: High Cycle Rate

System is spraying more than 1 gpm. System will shut-down if spraying more than 1.1 gpm.

1. Reduce pressure and/or gun tip size.

### Status Code 9: Low Tank Level

The tank level sensors sense ISO and RES material density inside the tank, and warns or shuts down, depending on settings of DIP switch 5. See **DIP Switch Settings**, page 30.

1. Add material to supply tank, if necessary.
2. Check that the tank level sensor is in contact with the surface of the tank. Replace if necessary. See **Tank Fluid Level Sensors**, page 56.

3. Check J6 connections on control board. See Table 8, page 46.

Level Sensor LED	Status
Green - on	Sensor is powered
Green - off	Sensor is not powered
Yellow - on	Sensor detects material
Yellow - off	Sensor does not detect material

### Status Code 11: Locked Motor Rotor

Verify that pumps are not seized and move freely. The motor is unable to turn. Replace motor, page 54.

Shut off unit and contact distributor before resuming operation.

### Status Code 12: Motor Controller Overvoltage

Too much voltage connected to control board. See **Technical Data**, page 79, for power requirements.

Cycle power and check status indicator to see if error is still active.

### Status Code 13: Motor Controller Undervoltage

Not enough voltage connected to control board. See **Technical Data**, page 79, for power requirements.

Cycle power and check status indicator to see if error is still active.

### Status Code 14: Motor Controller High Temperature



The motor control board is too hot.

Shutdown and move Reactor to a cooler location. Allow 1 hour for cooling.

### Status Code 15-19: Motor Controller Faults

Cycle power. If error is still present, replace board. See, page 45.

## DIP Switch Settings

						
To avoid electric shock, always unplug both power cords before servicing Reactor and wait one minute.						

1. Turn power off and unplug power cords from wall outlets.
2. Remove screws and display cover (26).

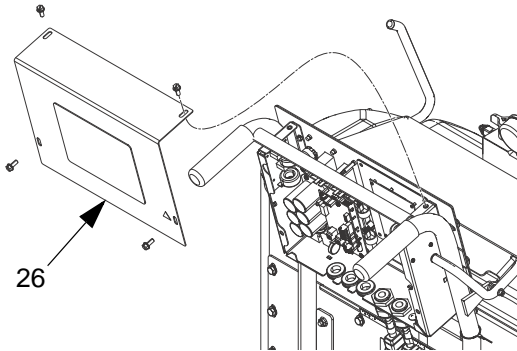

ti21923a

3. Locate the DIP switch on the control board.

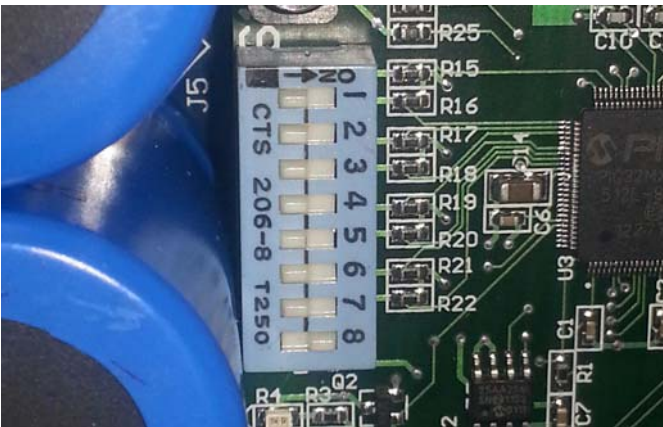

**Fig. 6: DIP Switch**

4. Set DIP switches to the desired positions. See **DIP Switch Settings and Functions**, page 31
5. Replace display cover (26) and plug in unit.
6. Cycle power switch to activate changes to DIP switch.

## DIP Switch Settings and Functions

DIP Switch Settings and Functions		
DIP Switch and Function	OFF	ON
<b>DIP Switch 1</b> If selected, displays a status code or displays a status code and causes shutdown if the pressure imbalance exceeds selection made in DIP Switch 2.	DEVIATION	DEVIATION AND SHUTDOWN
<b>DIP Switch 2</b> Select pressure imbalance limits, that if exceeded, will cause a deviation and a shutdown (if enabled).	See <b>Dip Switch 1 and 2 Settings</b> table, page 31	
<b>DIP Switch 3</b> If selected, causes shutdown or displays a status code due to deviation of pressure from setpoint exceeds selection made in DIP Switch 4.	DEVIATION	*SHUTDOWN
<b>DIP Switch 4</b> Causes deviation if pressure setpoint is greater than:	300 psi (2.1 MPa, 21 bar)  (25% if < 800 psi [5.6 MPa, 56 bar])	*500 psi (3.5 MPa, 35 bar)  (40% if < 800 psi [5.6 MPa, 56 bar])
<b>DIP Switch 5</b> Causes shutdown or displays a status code for low fluid level in tanks.	*DEVIATION	SHUTDOWN
<b>DIP Switch 6</b> Enables or disables boost heat.	DISABLE	*ENABLE
<b>DIP Switch 7</b>	Not used	
<b>DIP Switch 8</b>	Not used	

\* Default DIP Switch Settings

DIP Switch 1 and 2 Settings			
DIP Switch 1	DIP Switch 2	Deviation	Shutdown
Off	Off	300 psi (2.1 MPa, 21 bar)	---
Off	*On	500 psi (3.5 MPa, 35 bar)	---
*On	Off	300 psi (2.1 MPa, 21 bar)	500 psi (3.5 MPa, 35 bar)
*On	*On	500 psi (3.5 MPa, 35 bar)	800 psi (5.6 MPa, 56 bar)

## Heat Control Diagnostic Codes

Heat control diagnostic codes appear on the temperature display.

These alarms turn off heat. Codes E03 and E04 can be

cleared by pressing  .

1. To clear other codes:
2. Shut off Heater Power.



3. Shut off Motor Power.



4. Turn on Motor Power and Heater power to clear.



Code	Code Name	Alarm Zone	Corrective Action page
01	High fluid temperature	Individual	32
02	High zone current	Individual	33
03	No zone current	Individual	33
04	Thermocouple not connected	Individual	33

### E01: High Fluid Temperature

- Thermocouple ISO or RES (310) senses a fluid temperature above 260°F (71°C).
- Overtemperature switch ISO or RES (308) senses a fluid temperature above 230°F (110°C) and opens. At 190°F (87°C) the switch closes again.
- Thermocouple ISO or RES (310) fails, is damaged, is not touching the heater element (307), or has a poor connection to the temperature control board.
- Overtemperature switch (308) fails in the open position.
- The temperature control board fails to turn off any heat zone.
- Zone power wires or thermocouples are switched from one zone to another.

- Failed heater element where thermocouple is installed.
- Loose wire

### E01 Checks

						
---	---	--	--	--	--	--

Troubleshooting this equipment requires access to parts that may cause electric shock or other serious injury if work is not performed properly. Have a qualified electrician perform all electrical troubleshooting. Be sure to shut off all power to the equipment before repairing.

**NOTE:** Before checking the thermocouple, note which zone (ISO or RES) has high fluid temperature.

1. Check that connector B is firmly plugged into heater control module. See **Temperature Control Modules Connections**, page 48.
2. Clean and re-plug connections.
3. Check connections between the temperature control module and overtemperature switch, and between the temperature control module and thermocouples. Ensure all wires are securely connected to connector B on heater control module. See Table 7, page 33.



4. Remove connector B from heater control module and check continuity of thermocouples by measuring resistance across pins on the plug end.
5. Verify fluid temperature, using an external temperature sensing device.

**Table 7: Connector B Resistance Measurements**

120V		230V		Description	Reading
Connector	Pin	Connector	Pin		
B1	1, 2	B1	1, 2	Overtemperature Switch	nearly 0 ohms
B2	1	B1	5	Thermocouple ISO, R (red)	4-6 ohms
B2	2	B1	6	Thermocouple ISO, Y (yellow)	
B2	4	B1	8	Thermocouple RES, R (red)	4-6 ohms
B2	5	B1	9	Thermocouple RES, Y (yellow)	
B2	3	B1	3-4,7,10	Unused	N/A

**If temperature is too high (sensor reading is 260°F [127°C] or above):**

6. Check if thermocouples are damaged, or not contacting the heater element, see FIG. 16, page 50.
7. Check if temperature control module turns off when equipment reaches temperature setpoint:
  - a. Set temperature setpoints far below displayed temperature.
  - b. Turn zone on. If temperature rises steadily, power board is failing.
  - c. Verify by exchanging with another power module. See **Replace Temperature Control Modules**, page 47.
  - d. If the exchanged module does not fix the problem, the power module is not the cause.
8. Verify continuity of heater elements with an ohmmeter, see page 49.

**E02: High zone current**

When there is a high current error, the LED on that zone's module will turn red while the error is displayed.

1. See **Before Beginning Repair**, page 40.
2. Exchange zone module with another one. Turn zone on and check for error. If error disappears, replace faulty module.

**E03: No zone current**

When a no current error occurs, the LED on the specific zone's module turns red when the error is displayed.

1. Check for tripped circuit breaker on Reactor or at power source of that zone. Replace circuit breaker if it trips habitually.
2. Check for loose or broken connection at that zone.
3. Exchange zone module with another one. Turn zone on and check for error (see page 47). If error disappears, replace faulty module.
4. If E03 occurs for all zones, the contactor may not be closing. Verify wiring from heater control to contactor coil.

**E04: Thermocouple disconnected**

1. Check temperature sensor connections to green connectors (B) on temperature control module. See **Temperature Control Modules Connections**, page 48.
2. Unplug and re-plug sensor wires.

## Reactor Electronics



Before performing any troubleshooting procedures:



1. Shut off Heater Power.



2. Shut off Motor Power.



3. Relieve pressure, page 23.
4. Allow equipment to cool.
5. Try the recommended solutions in the order given for each problem, to avoid unnecessary repairs. Also, determine that all circuit breakers, switches, and controls are properly set and wiring is correct before assuming there is a problem.

PROBLEM	CAUSE	SOLUTION
Temperature display does not illuminate.	Display disconnected.	Check cable connections, page 46.
	Display cable damaged or corroded.	Clean connections; replace cable if is damaged.
	Blown fuse.	Replace fuse (73) in fuse holder on DIN rail assembly located under electronics cover (55).
	Failed circuit board.	Display is failing. Replace.
	Loose display cables on control board.	Check cable connections to each display, page 73.
	Failed control board (displays get power from control board).	Remove access panel. Check if board LED is lighted. If not, replace board, page 45.
	Inadequate power to control board.	Check that power supply meets requirements.
	Loose power cable.	Check cable connections, page 73.
	Heater power switch circuit breaker tripped.	Display is powered from heater power circuit breaker. Cycle heater power off  , then on  to reset breaker.
Erratic display; display turns on and off.	Low voltage.	Ensure input voltage is within specifications, page <b>Technical Data</b> , page 79.
	Poor display connection.	Check cable connections, page 73. Replace damaged cable.
	Display cable damaged or corroded.	Clean connections; replace cable if is damaged.

PROBLEM	CAUSE	SOLUTION
Display does not respond properly to button pushes.	Poor display connection.	Check cable connections, page 73. Replace damaged cable.
	Display cable damaged or corroded.	Clean connections, page 73. Replace damaged cable.
	Ribbon cable on display circuit board disconnected or broken.	Connect cable, page 73, or replace.
	Broken display button.	Replace, page 43.
Fan not working.	Loose wire.	Check fan wire.
	Defective fan.	Replace, page 55.

## Heaters



Before performing any troubleshooting procedures:

1. Shut off Heater Power.



2. Shut off Motor Power.



3. Relieve pressure, page 23.
4. Allow equipment to cool.

Try the recommended solutions in the order given for each problem, to avoid unnecessary repairs. Also, determine that all circuit breakers, switches, and controls are properly set and wiring is correct before assuming there is a problem.

PROBLEM	CAUSE	SOLUTION
Primary heater(s) does not heat.	Heat turned off.	Press <b>ISO</b> or <b>RES</b> zone  keys.
	Temperature control alarm.	Check temperature display for diagnostic code, page 32.
	Signal failure from thermocouple.	See <b>E04: Thermocouple disconnected</b> , page 33.
	Failed heater element.	Check resistance of heater elements. See <b>Test Heater Element</b> , page 49.
Control of primary heat is abnormal; high temperature overshoots or E01 error occurs intermittently.	Dirty thermocouple connections.	Examine connection of thermocouples to long green plug on heater control board. Unplug and re-plug thermocouple wires, cleaning off any debris. For 120V, unplug and re-plug long green connector. For 230V, unplug and re-plug green connector(s) B.
	Thermocouple not contacting heater element.	Loosen ferrule nut (N), push in thermocouple (310) so tip (T) contacts heater element (307). Holding thermocouple tip (T) against heater element, tighten ferrule nut (N) 1/4 turn past tight. See page 50 for illustration.
	Failed heater element.	See <b>Heaters</b> , page 36.
	Signal failure from thermocouple.	See <b>E04: Thermocouple disconnected</b> , page 33.
	Thermocouple wired incorrectly.	See <b>E04: Thermocouple disconnected</b> , page 33. Power up zones one at a time and verify that temperature for each zone rises.

# Proportioner



Before performing any troubleshooting procedures:

1. Shut off Heater Power.





2. Shut off Motor Power.



3. Relieve pressure, page 23.
4. Allow equipment to cool.

Try the recommended solutions in the order given for each problem, to avoid unnecessary repairs. Also, determine that all circuit breakers, switches, and controls are properly set and wiring is correct before assuming there is a problem.

PROBLEM	CAUSE	SOLUTION
Reactor does not operate.	No power.	Plug in both power cords.
		Cycle Motor Power and Heater Power off  , then on  to reset both breakers.
Motor does not operate.	Power turned on while function knob set to a run position.	Set function knob to Stop/Park  , once status LED turns on. Then select desired function.
	Loose connection on control board.	Check connection at motor power connections on bottom board. See FIG. 12, page 46.
	Worn brushes.	Check both sides. Replace brushes worn to less than 1/2 in. (13 mm), see page 55.
	Broken or misaligned brush springs.	Realign or replace, page 55.
	Brushes or springs binding in brush holder.	Clean brush holder and align brush leads for free movement.
	Shorted armature.	Replace motor, page 54.
	Check motor commutator for burn spots, black pitting, or other damage.	Remove motor. Have motor shop resurface commutator, or replace motor, page 54.
Pump output low.	Failed control board.	Replace board. See page 45.
	Plugged fluid inlet strainer.	Clear, see page 24.
	Leaking or plugged piston valve or intake valve in displacement pump.	Check valves. See pump manual.

PROBLEM	CAUSE	SOLUTION
One side doesn't come up to pressure in spray mode.	Low fluid in tank.	Refill.
	Dirty or damaged Recirc/Spray valve.	Clean or repair, page 41.
	Plugged fluid inlet strainer.	Clear, see page 24.
	Pump intake valve plugged or stuck open.	Clean pump intake valve. See page 42.
	Material is too viscous to pump.	Warm material before adding to tanks.
Pressure is higher on one side when setting pressure with function knob.	Pump intake valve partially plugged.	Clean pump intake valve. See page 42.
	Air in hose. Fluid is compressible.	Purge air from hose.
	Unequal size hoses or unequal hose construction.	Use matching hoses, or balance pressures before spraying.
Pressures are not balanced when running, but pressure is generated and holds on both strokes.	Unequal viscosities.	Change temperature setting to balance viscosities.
		Change restrictor at mix point to balance back pressure.
	Restriction on one side.	Clean mix module or restrictor at mix manifold.
		Clean gun check valve screens.
Fluid leak in pump packing nut area.	Worn throat seals.	Replace. See pump manual.
Pressure doesn't hold when stalled against gun in spray mode.	Leaking Recirc/Spray valve.	Repair, page 41.
	Leaking piston valve or intake valve in displacement pump.	Repair. See pump manual.
	Leaking gun shutoff.	Repair. See gun manual.
Pressure is higher on RES side during startup of recirculation, especially in High Recirc mode.	This is normal. RES is typically higher viscosity than ISO until the material is heated during recirculation.	No action required.
One gauge shows half as many pulses as the other when pumps are cycling.	Loss of pressure on downstroke.	Intake valve is leaking or not closing. Clean or replace valve; see page 41.
	Loss of pressure on upstroke.	Piston valve is leaking or not closing. Clean or replace valve or packings; see page 41.
Status indicator not lit.	Function knob is not set to Park/Off when power is applied.	Turn function knob to Park/Off.
	Loose indicator cable.	Check that cable is connected at J3 on top motor control board. See page 46.
	Failed control board.	Replace board. See page 45.
	Shorted pressure transducer or potentiometer input.	See <b>Control Board LEDs</b> , page 45 for troubleshooting.

PROBLEM	CAUSE	SOLUTION
ISO side rich; lack of RES side.	ISO side gauge is low.	RES side restriction downstream of gauge. Check gun check valve screen, mix module, or mix manifold restrictor.
	RES side gauge is low.	RES side material supply problem. Check RES side inlet strainer and pump intake valve.
RES side rich; lack of ISO side.	ISO side gauge is low.	ISO side material supply problem. Check ISO side inlet strainer and pump intake valve.
	RES side gauge is low.	ISO side restriction downstream of gauge. Check gun check valve screen, mix module, or mix manifold restrictor.
Tank level sensor does not sense empty tank (indicator LED on control panel never blinks).	Material build up.	Flush and clean inside of tanks. Clean outside of sensor and recessed area on tank.
	LED wires disconnected inside control panel.	Reconnect LED wires.
	Tank level sensor sensitivity is too high.	Reset tank fluid level sensor sensitivity, page 57.
Tank level sensor does not sense full tank (indicator LED on control panel always blinking).	Tank level sensor is too far away from tank.	Check position of both tank level sensors. See <b>Tank Fluid Level Sensors</b> , page 56.
	Sensor wires disconnected.	Reconnect sensor wires in display panel.
	Tank level sensor sensitivity is too low.	Reset tank fluid level sensor sensitivity, page 57.

# Repair

## Before Beginning Repair



Repairing this equipment requires access to parts which may cause electric shock or other serious injury if work is not performed properly. Have a qualified electrician connect power and ground to main power switch terminals, see page 15. Be sure to shut off all power to the equipment before repairing.

1. Flush if possible, see page 25. If not possible, clean all parts with solvent immediately after removal, to prevent isocyanate from crystallizing due to moisture in the atmosphere.

2. Set function knob to Stop/Park .

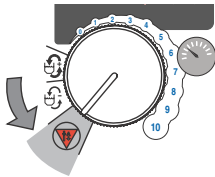

ti21490a

3. Shut off Motor Power.



4. Shut off Heater Power. Allow system to cool.



5. Relieve pressure, page 23.
6. Disconnect heater and motor power cords.

## Remove Supply Tank



1. See **Before Beginning Repair**, page 40.
2. Relieve pressure, page 23.
3. Flush, page 25.
4. Place waste container under y-strainer.
5. Close fluid valve (V).

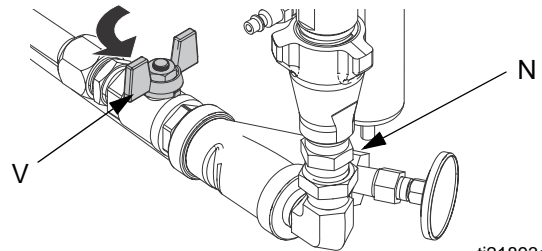

ti21893a

6. Remove filter drain hex nut (N) and drain material.
7. Remove recirculation tubes (P) and place in waste containers.

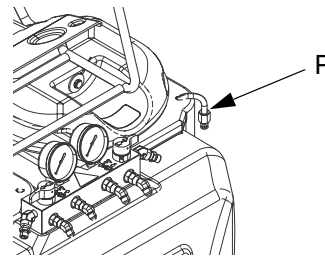



8. Disconnect swivel elbow at pump fluid inlet.
9. Remove six screws (28) holding tank (27) to cart frame.

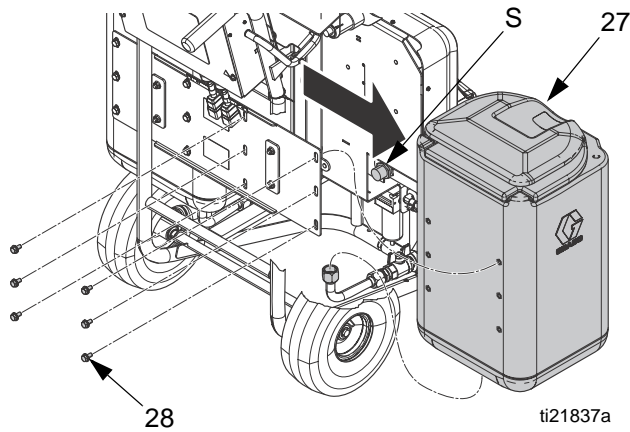

10. Loosen nut and slide tank level sensor (S) away from the tank.
11. Pivot top of tank to side and remove the tank, with fluid inlet fittings, off the cart.
12. Reinstall in reverse order. Torque screws (28) to 125 in.-lbs (14 N•m).

## Replace Recirc/Spray Valves

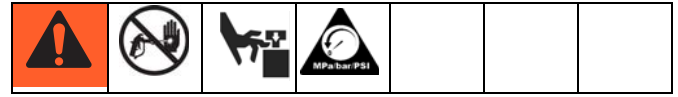

1. See **Before Beginning Repair**, page 40.
2. Relieve pressure, page 23.
3. See FIG. 7. Disassemble Recirc/Spray valves. Clean and inspect all parts for damage.
4. Ensure that the seat (453a) and gasket (453b) are positioned inside each valve cartridge (453).
5. Apply PTFE pipe sealant to all tapered pipe threads before reassembling.
6. Reassemble in reverse order, following all notes in FIG. 7.

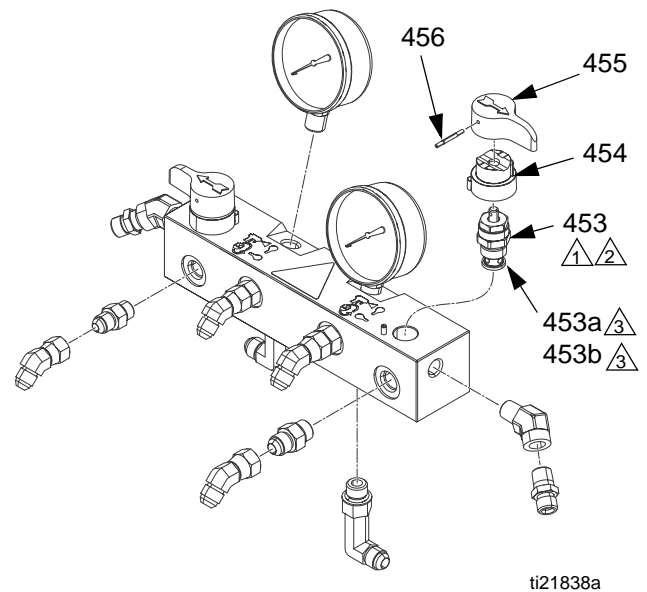

- Ⓐ Torque to 250 in-lb (28 N•m).
- Ⓑ Use blue threadlocker on valve cartridge threads into manifold.
- Ⓒ Part of item 453.

**FIG. 7: Recirc/Spray Valves**

## Displacement Pump

**NOTE:** Use dropcloth or rags to protect Reactor and surrounding area from spills.



1. See **Before Beginning Repair**, page 40.
2. Relieve pressure, page 23.
3. Close both fluid valves (V).

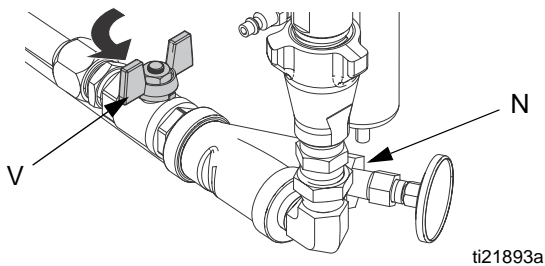

**NOTE:** Use dropcloth or rags to protect Reactor and surrounding area from spills.

4. Open filter drain hex nut (N) on y-strainer.

### Remove Intake Valve Only

**NOTE:** If pump is not generating any pressure, the intake ball check may be stuck closed with dried material.

If the pump is not generating pressure on the down-stroke, intake ball check may be stuck open.

Either of these conditions can be serviced with the pump in place.

5. Disconnect fluid inlet (C) and swing it aside.
6. Remove intake valve by hitting ears (E) firmly, right-to-left, with a non-sparking hammer. Unscrew from pump. See displacement pump manual for repair and parts.

### Remove Entire Pump Assembly

7. Disconnect fluid inlet (C) and outlet (D) lines. Also disconnect steel outlet tube (46) from heater inlet.

8. Remove pump rod cover (222). Push clip up in back and push pin (217) out. Loosen locknut (218) by hitting firmly right-to-left with a non-sparking hammer. Unscrew pump. See manual 311076 for pump repair and parts.
9. Install pump in reverse order of disassembly, following all notes in FIG. 8. Clean strainer (51). Reconnect fluid inlet (C) and outlet (D) lines.
10. Tighten fluid outlet fitting (D), then tighten locknut (218) by hitting firmly with a non-sparking hammer.
11. Set function knob to Slow Recirc . Purge air and prime. See **Purge Air and Flush Fluid From Lines**, page 18.

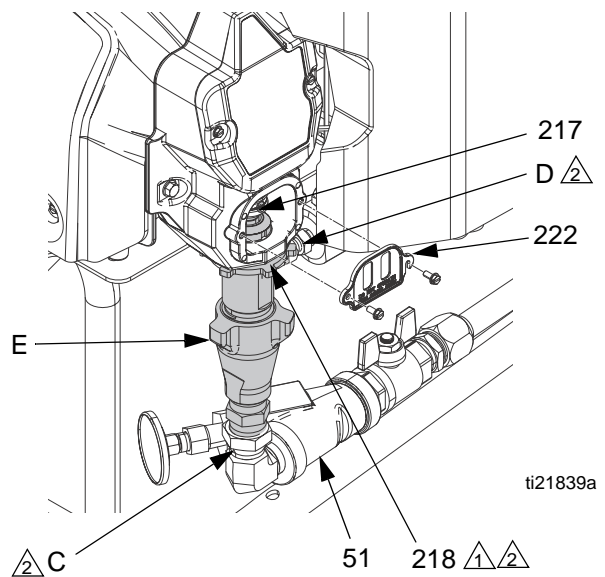

 Flat side faces up. Tighten by hitting firmly with non-sparking hammer.

 Lubricate threads with ISO oil or grease.

T17025a

**FIG. 8: Displacement Pump**

## Control Panel

### Replace Temperature Display



#### NOTICE

Before handling board, put on a static conductive wrist strap to protect against static discharge which can damage board. Follow instructions provided with wrist strap.

1. See **Before Beginning Repair**, page 40.
2. Remove screws (21) and display cover (26).

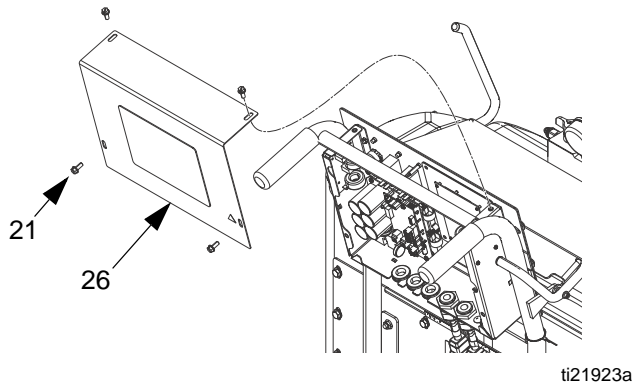

3. Put on static conductive wrist strap.
4. Disconnect main display cable (81) from upper right corner of temperature display (353). See FIG. 10.
5. Remove jumper (373) from back of display (353). Set aside and install jumper on new display.
6. Disconnect ribbon cable(s) (R) from back of display; see FIG. 10.
7. Remove nuts (360) from plate (351).
8. Disassemble display (353), see detail in FIG. 10.
9. Reassemble in reverse order, see FIG. 10. Apply medium strength thread sealant where shown.

### Replace Function Knob/Potentiometer



1. See **Before Beginning Repair**, page 40.
2. Remove screws (21) and back cover (26).
3. Disconnect potentiometer wires from J5 on motor control board (354). See FIG. 12, page 46.
4. See FIG. 9. Remove two setscrews (356a) and pull function knob (356) off potentiometer (357) shaft.
5. Remove nut (N, part of 357) and detent plate (358).
6. Install new potentiometer (357) in reverse order. Position potentiometer so slot (S) is horizontal. Position knob (356) so pointer (P) faces up. Install knob on shaft so slot (S) engages alignment pin in knob. Push knob onto shaft against detent spring before tightening setscrews (356a).
7. Reconnect potentiometer wires to J5.

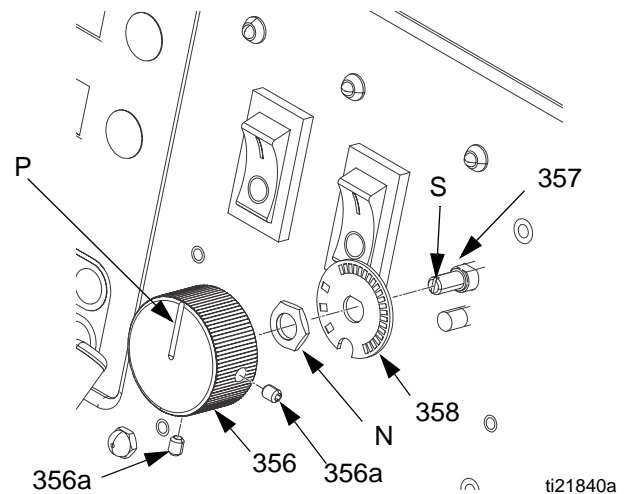

**FIG. 9: Function Knob/Potentiometer**

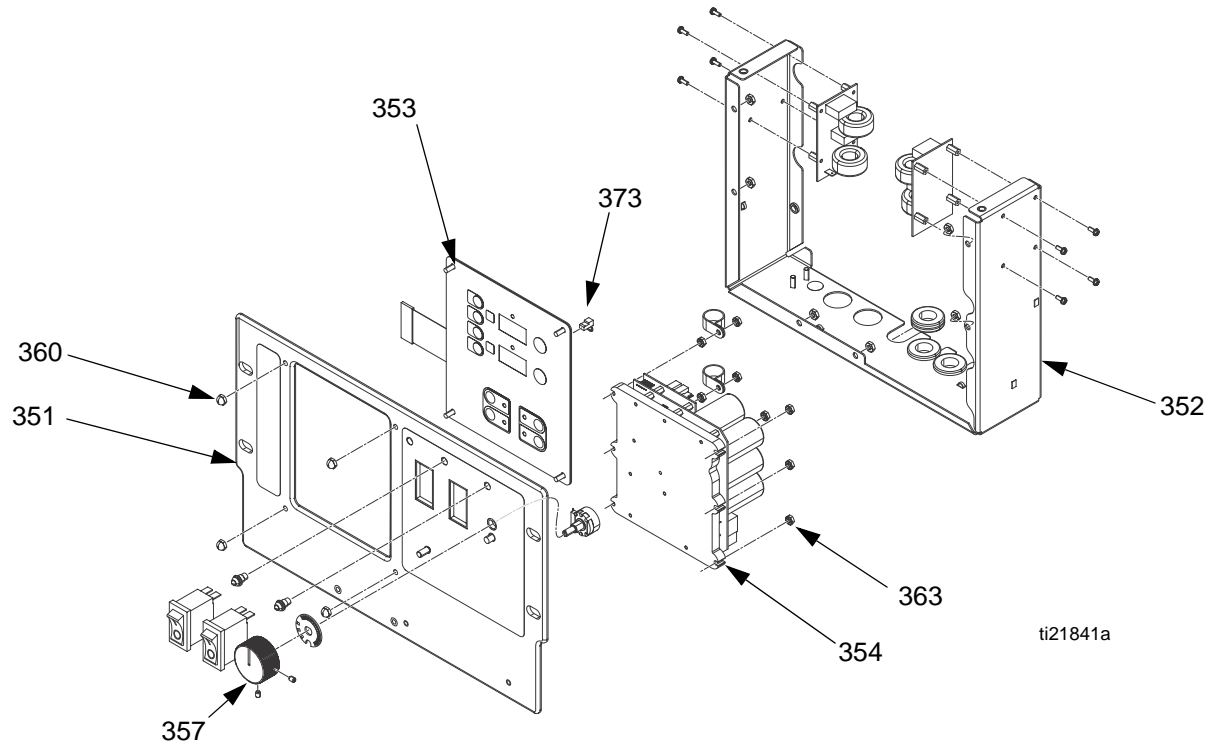

**FIG. 10: Control Panel**

# Motor Control

## Power Bootup Check

**NOTE:** Power must be on to check. See FIG. 11 or location. Function is:

- Motor ready: LED on.
- Motor not ready: LED off.
- Status code (motor not running): LED blinks status code.
- Multiple status codes are separated by a longer LED off duration.

## Control Board LEDs

If LEDs on bottom board are on and the top board LEDs are off, the following may have occurred:

- A pressure transducer shorted out.
- A short occurred between the power and ground pin of the potentiometer.

Board	LED	State	Description
Top	R4	Red: on	Hardware or software failure
	G1	Green: on	Power on
Bottom	D4	Red: on	Hardware or software failure
	D16	Green: on	Power on

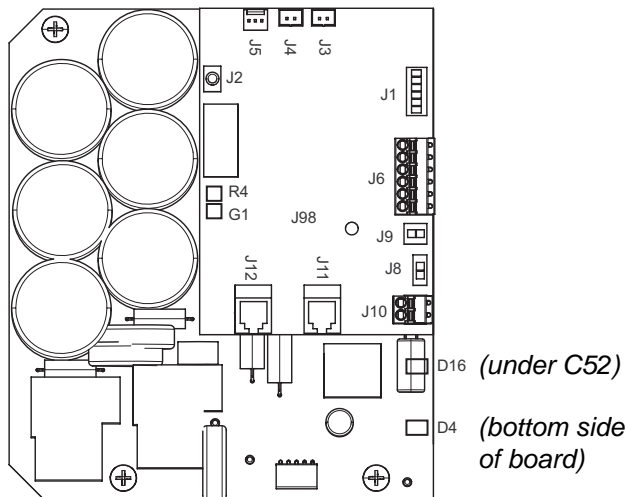
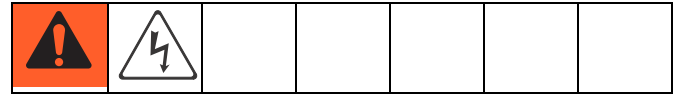

FIG. 11

## Replace Control Board



**NOTE:** Check motor before replacing board. See **Test Motor**, page 54.

1. See **Before Beginning Repair**, page 40.
2. Remove access cover (26) on back of cart to expose control board (354).

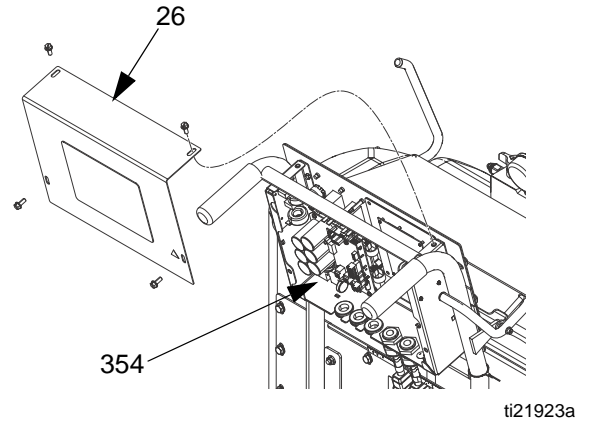

3. Disconnect all cables and connectors from board (354). See Table 8, page 46.
4. Remove six nuts (363) and remove board from control board (354). See FIG. 10, page 44.
5. Install new board in reverse order.

**Table 8: Control Board Connectors (see FIG. 12)**

Top Board Connectors			Bottom Board Connectors	
Board Jack	Pin	Description	Connector	Description
J1	n/a	Not Used	Female Quick Connect Terminals	Power
J2	n/a	Not Used	Plug Housing with Male Blades	Motor Power
J3	n/a	Error LED		
J4	n/a	Tank Level LED		
J5	n/a	Function Knob		
J6	1	Brown - ISO Sensor V+		
	2	Blue - ISO Sensor V-		
	3	Black - ISO Sensor Signal		
	4	Brown - RES Sensor V+		
	5	Blue - RES Sensor V-		
	6	Black - RES Sensor Signal		
J8	n/a	Boost Power Relay		
J9	n/a	Motor Overtemperature		
J10	n/a	Cycle Switch		
J11	n/a	ISO Pressure Transducer		
J12	n/a	RES Pressure Transducer		

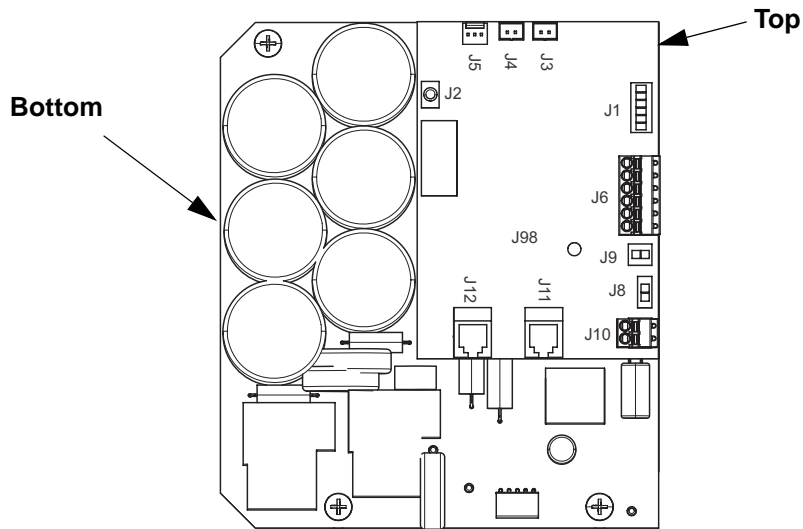

**FIG. 12: Wiring Connections**

## Replace Temperature Control Modules

### NOTICE

Before handling assembly put on a static conductive wrist strap to protect against discharge which can damage assembly. Follow instructions provided with wrist strap.

1. See **Before Beginning Repair**, page 40.
2. Remove heater shroud (89) and electronics cover (55).

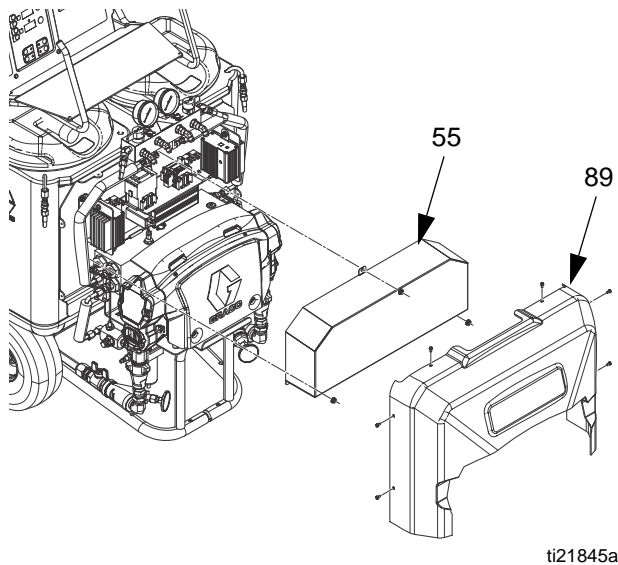

3. Put on static conductive wrist strap.

4. Disconnect all cables and connectors from temperature control module (59).

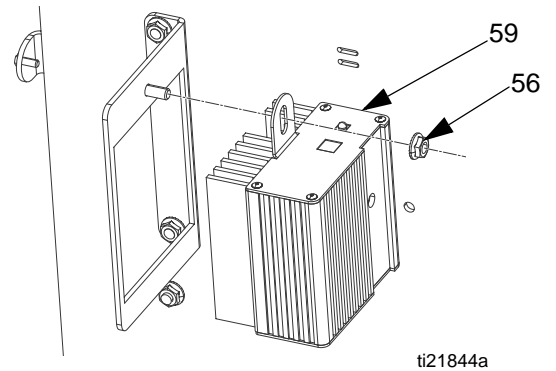

**FIG. 13**

5. Remove hex nut (56) and replace defective module.
6. Install new module in reverse order. Connect all cables and connectors.

### Temperature Control Modules Connections

Table 9: Heater Control Module Connections

Connector	Description	
	120V	230V
DATA (A)	Not used	
Sensor (B)	See Table 11	
DISPLAY (C)	Display	
COMMUNICATION (D)	Communication to power boards	
PROGRAM (E)	Software programming	
BOOT (F)	Software bootloader	

Table 9: Heater Control Module Connections

Connector	Description	
	120V	230V
POWER/RELAY (G)	Circuit board power input and contactor control output	

Table 10: Temperature Power Module Connections

Connector	Description
COMMUNICATION (H)	Communication to control board
POWER (J)	Power to heater

Table 11: Sensor B Connections

120V		230V		Description
Connector	Pin	Connector	Pin	
B1	1, 2	B1	1, 2	Overtemperature Switch
B2	1	B1	5	Thermocouple ISO, R (red)
B2	2	B1	6	Thermocouple ISO, Y (yellow)
B2	4	B1	8	Thermocouple RES, R (red)
B2	5	B1	9	Thermocouple RES, Y (yellow)
B2	3	B1	3-4,7,10	Unused

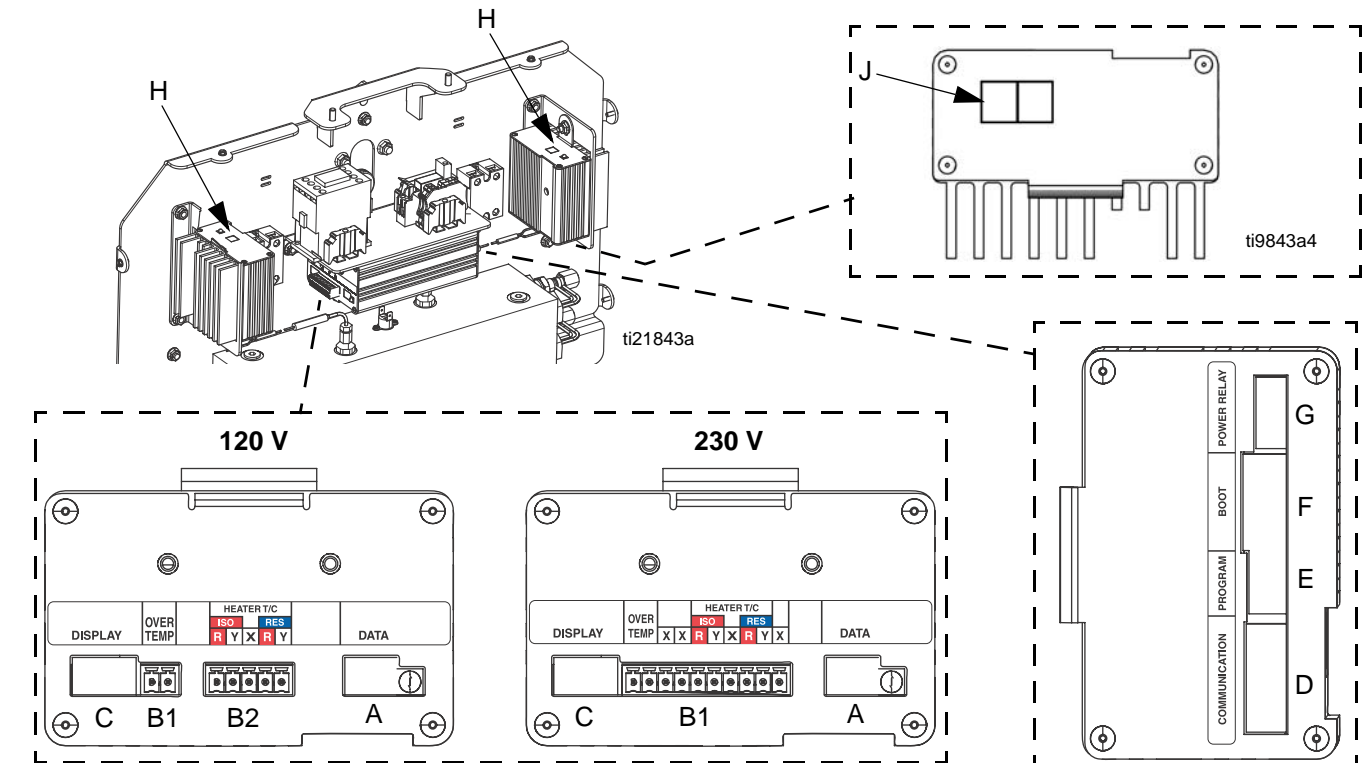
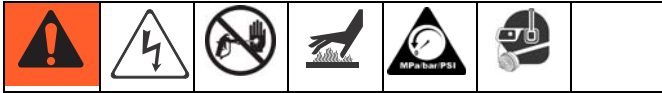

FIG. 14: Temperature Control Module Connections



# Heater

## Test Heater Element



1. See **Before Beginning Repair**, page 40.
2. Wait for heater to cool.
3. Remove heater shroud (90) and electronics cover (55).

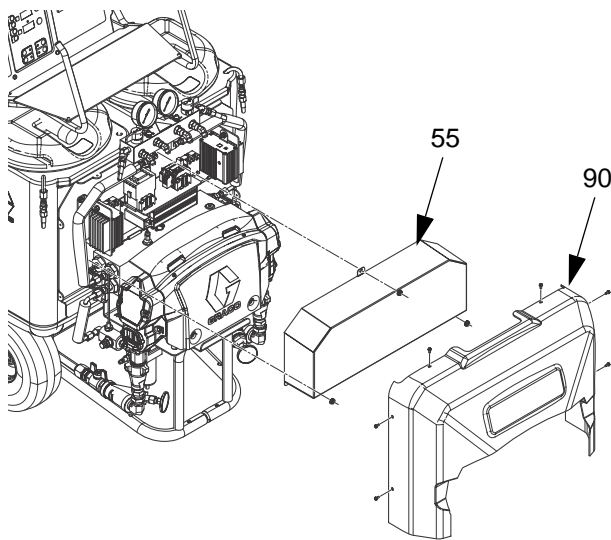

ti21893a

**FIG. 15**

4. Disconnect heater element wires from heater wire connector. Test with ohmmeter. Replace heater element if the resistance reading does not fall within the range.

Heater Voltage	Heater Wattage Per Zone	Element Wattage	Ohms
120	1500	500	24-32
		1000	12-16
230	2000	620	73-94
		1380	32-43

## Remove Heater Element

1. To remove heater element, first remove thermocouple (310) to avoid damage, see step 7, page 50.
2. Remove heater element (307) from housing (301). Be careful not to spill any fluid left in housing.
3. Inspect element.

**NOTE:** It should be relatively smooth and shiny. If there is a crusted, burnt, ash-like material adhered to element or sheath shows pitting marks, replace element.

4. Install new heater element (307), holding mixer (309) so it does not block thermocouple port (P).
5. Reinstall thermocouple, page 50.
6. Reconnect heater element leadwires to heater wire connector.
7. Replace heater shroud (90) and electronics cover (55).

## Line Voltage

The primary heaters output their rated wattage at either 120 Vac or 230 Vac, depending on system. Low line voltage will reduce power available and the heaters will not perform at full capability.

## Thermocouple

1. See **Before Beginning Repair**, page 40.



2. Wait for heaters to cool.
3. Remove heater shroud (90) and electronics cover (55). See FIG. 15, page 49.
4. Loosen and remove temperature control module bracket mounting fasteners (56). Move control module up and out of the way to access thermocouple.
5. Disconnect thermocouple wires from B on temperature control module. See **Temperature Control Modules Connections**, page 48.
6. Clip cable ties as necessary. Note path as wires must be replaced in the same way.
7. See FIG. 16. Loosen ferrule nut (N). Remove thermocouple (310) from heater housing (301), then remove thermocouple housing (H). Do not remove the thermocouple adapter (305) unless necessary. If adapter must be removed, ensure that mixer (309) is out of the way when replacing the adapter.

8. Replace thermocouple, FIG. 16.
  - a. Remove protective tape from thermocouple tip (T).
  - b. Apply PTFE tape and thread sealant to male threads and tighten thermocouple housing (H) into adapter (305).
  - c. Push in thermocouple (310) so tip (T) contacts heater element (307).
  - d. Holding thermocouple (T) against heater element, tighten ferrule nut (N) 1/4 turn past tight.
9. Route wires (S) into cart and thread into bundle as before. Reconnect wires to board.
10. Replace heater shroud (90) and electronics cover (55). See FIG. 15, page 49.
11. Turn on heaters ISO and RES simultaneously to test. Temperatures should rise at same rate. If one heater is low, loosen ferrule nut (N) and tighten thermocouple housing (H) to ensure thermocouple tip (T) contacts element (307).

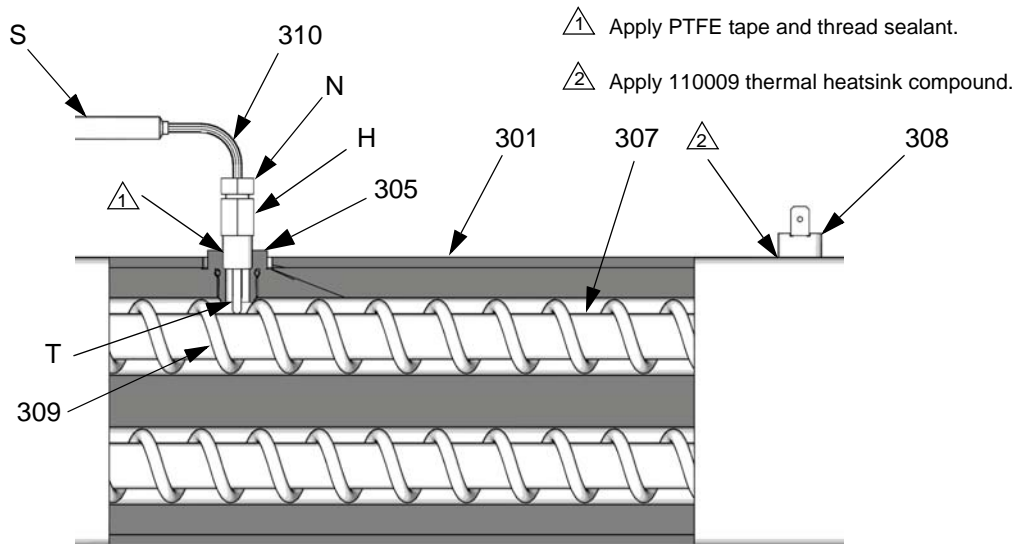

ti7924a

**FIG. 16. Thermocouple**

## Overtemperature Switch

1. See **Before Beginning Repair**, page 40.



2. Wait for heaters to cool.
3. Remove heater shroud (90) and electronics cover (55). See FIG. 15, page 49.
4. Disconnect one leadwire from overtemperature switch (308), FIG. 16. Test across switch with ohmmeter. Resistance must be approximately 0 ohms.
5. If switch fails test, remove wires and screws. Discard failed switch. Apply thermal compound 110009, install new switch in same location on housing (301), and secure with screws (311). Reconnect wires.

**NOTE:** If wires need replacement, disconnect from heater control module. See **Electrical Wiring Identification**, page 73.

## Pressure Transducers

1. See **Before Beginning Repair**, page 40.

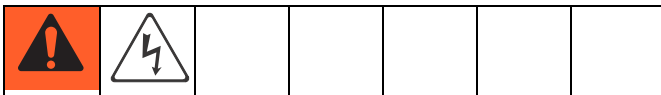

2. Remove back cover (26).

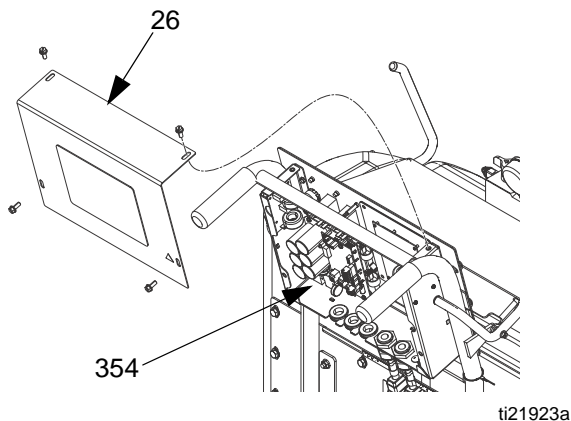

3. Disconnect transducer cables from J11 and J12 connectors. Reverse ISO and RES transducer connections and check if status codes follows the bad transducer.

4. Replace transducer if the transducer fails test.
  - a. Remove supply tank, page 40.
  - b. Follow transducer cable on cart frame and cut zip ties. Disconnect transducer from pump outlet manifold.
  - c. Install o-ring (553) on new transducer (554). Apply lubricant to o-ring (553).
  - d. Install transducer (554) in manifold. Mark end of cable with tape (red = ISO, blue = RES).
  - e. Route cable back through cart frame to the control board. See FIG. 12, page 46.
  - f. Install supply tank.

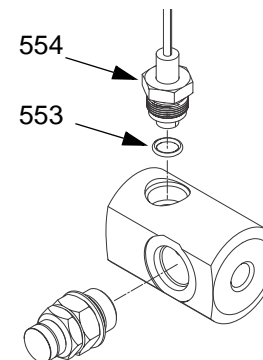

ti21846a

**FIG. 17. Transducer**

## Drive Housing

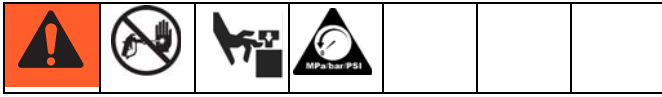

### Removal

1. See **Before Beginning Repair**, page 40.
2. Remove screws (207) and end covers (229), see FIG. 18.

**NOTE:** Examine connecting rod (216). If rod needs replacing, first remove the pump (219), page 42.

#### NOTICE

To prevent equipment damage, do not drop gear reducer (214) and crankshaft (210) when removing drive housing (215). These parts may stay engaged in motor end bell (MB) or may pull away with drive housing.

3. Disconnect pump inlet and outlet lines. Remove screws (220) and pull drive housing (215) off motor (201). Connecting rod (216) will disengage from crankshaft (210).
4. Examine crankshaft (210), gear reducer (214), thrust washers (208, 212), and bearings (209, 211, 213).

### Installation

1. Apply grease liberally to washers (208, 212), bearings (209, 211, 213), gear reducer (214), crankshaft (210), and inside drive housing (215). Grease is supplied with replacement parts kits.

**NOTE:** RES side crankshaft (210) includes the cycle counter magnet (224). When reassembling, be sure to install crankshaft with magnet on RES side.

If replacing crankshaft, remove magnet (224). Reinstall magnet in center of offset shaft on new crankshaft. Position shaft in Park position.

2. Install bronze bearings (211, 213) in drive housing (215), as shown.
3. Install bronze bearings (209, 211) and steel washer (208) on crankshaft (210). Install bronze bearing (213) and steel washer (212) on gear reducer (214).

4. Install gear reducer (214) and crankshaft (210) into motor end bell (MB).

**NOTE:** Crankshaft (210) must be in line with crankshaft at other end of motor. Pumps will move up and down together.

**NOTE:** If connecting rod (216) or pump (219) were removed, reassemble rod in housing and install pump, page **Displacement Pump**, page 42.

5. Push drive housing (215) onto motor (201). Install screws (220).
6. Install drive housing covers (229) and screws (207). Pumps must be in phase (both at same position in stroke).

# Replace Cycle Counter Switch

**NOTE:** RES side drive housing cover (229) includes the cycle counter switch (223), mounted in the cover. When reassembling, be sure to install cover with switch on RES side.

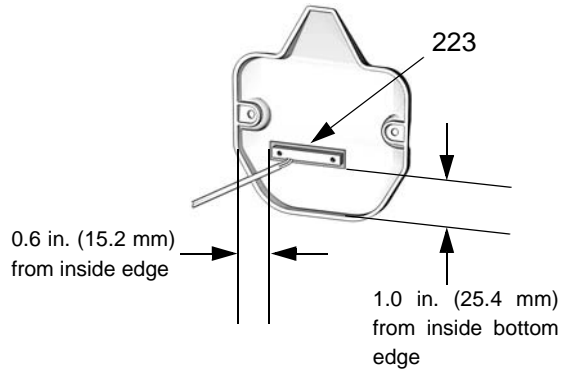

T17028a

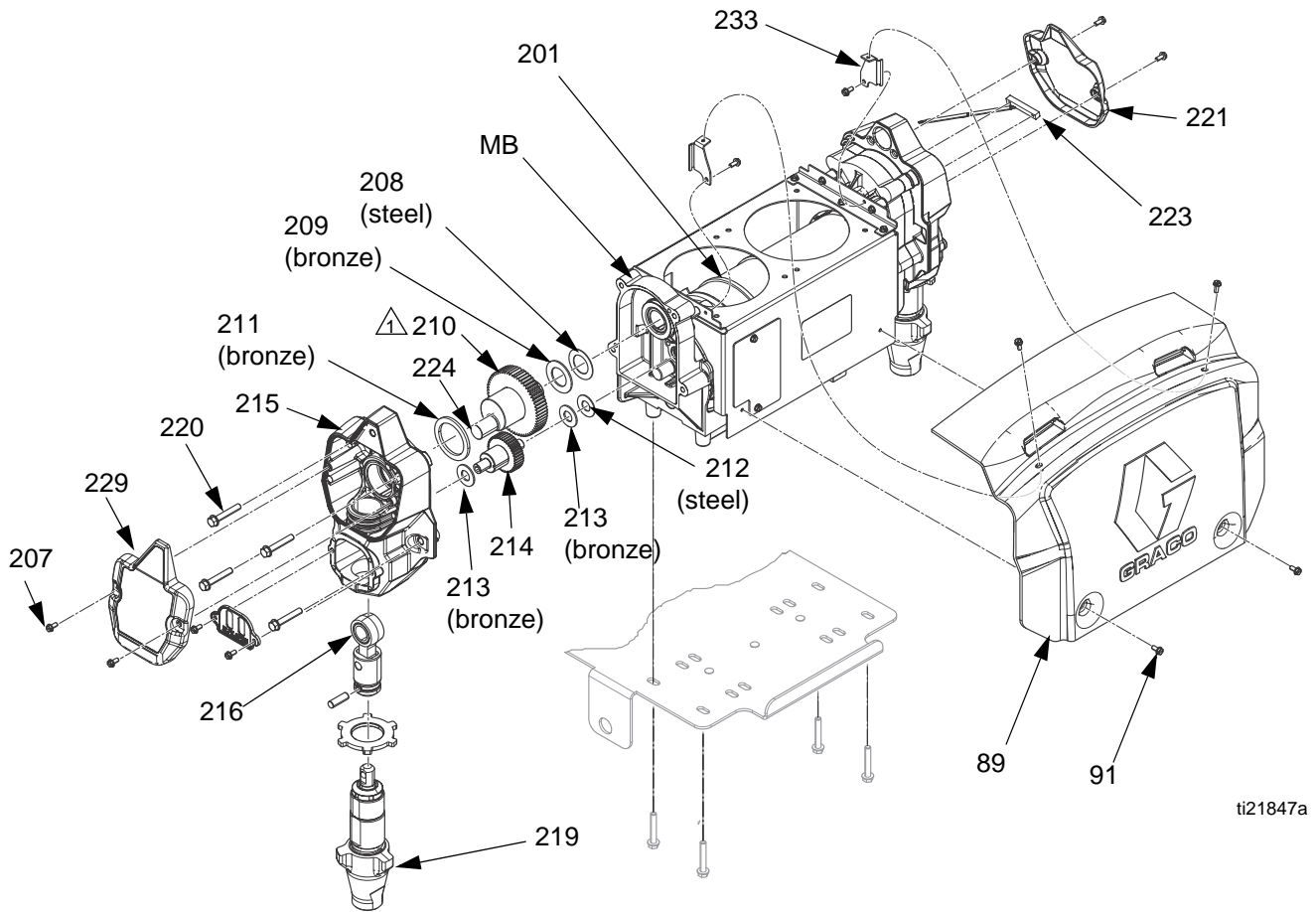

ti21847a

 Crankshaft must be in line with crankshaft at other end of motor, so pumps move up and down in unison.

**FIG. 18. Drive Housing**

## Electric Motor

### Test Motor

If motor is not locked up by pumps, it can be tested using a 9 V battery.

1. Open recirculating valves.
2. Disconnect motor connections from control board, see FIG. 12, page 46. Touch jumpers from battery to motor connections. Motor should turn slowly and smoothly.

### Removal

**NOTE:** See wiring schematic, page 46.



1. See **Before Beginning Repair**, page 40.
2. Relieve pressure, page 23.
3. Remove four screws (91), shroud (89), and mounting brackets (233). See FIG. 18.
4. Remove fans (16) and disconnect cable (80). See FIG. 20.
5. Remove drive housing/pump assemblies, page 52.
6. Remove display control cover (26). Disconnect motor cables as follows:
  - a. Unplug motor power connector before ferrite (88).
  - b. Unplug motor temp switch harness from connector J9 and remove grounding cable from grounding screw.
7. Remove RES supply tank. See **Remove Supply Tank**, page 40.
8. Cut zip ties.
9. Thread motor power switch harness and over temp switch out bottom of control module and cable channel, to free motor.

### NOTICE

To prevent dropping the motor, two people may be required to lift.

10. Remove screws (15) holding motor (201) to bracket. Lift motor off unit.
11. If replacing motor, remove shroud mounting bolts (207) and brackets (233) and set aside.

### Installation

1. If replacing motor, install fan assemblies (16) and shroud mounting brackets (233) on new motor (201).
2. Place motor (201) and fans (16) on unit. Thread motor switch harness through grommets in cart and into the back of the display. See FIG. 24, page 76.
3. Fasten motor (201) with screws (15) underneath. Do not tighten yet.
4. Plug motor temp switch harness to connector J9 and grounding cable from grounding screw.
5. Plug in motor power connector.
6. Secure all cables to cart frame with zip ties.
7. Install display control cover (26).
8. Install supply tank.
9. Install drive housing/pump assemblies, page 52. Reconnect inlet assemblies to pumps.
10. Torque screws (15) to 150 in.-lbs (17 N•m).
11. Return to service.

## Motor Brushes

**NOTE:** Replace brushes worn to less than 1/2 in. (13 mm). Brushes wear differently on each side of motor; check both sides. Brush Repair Kit 287735 is available; kit includes instruction sheet 406582.

**NOTE:** Motor commutator should be smooth. If not, resurface commutator or replace motor.



1. See **Before Beginning Repair**, page 40.
2. Relieve pressure, page 23.
3. Remove four screws (91) and motor shroud (89). See FIG. 18.
4. Remove fans (16) and disconnect cable (80). See FIG. 20.
5. Loosen pump inlet and outlet connections.
6. Remove the display control cover (26). Disconnect motor cables as follows:
  - a. Unplug motor power connector.
  - b. Unplug motor temp switch harness from connector J9. Disconnect grounding cable from grounding screw.
7. To replace the front motor brush:
  - a. Remove the two bolts and access cover plate. See FIG. 19.
  - b. Remove old brushes and install new ones supplied in kit.
8. To replace the rear motor brush:
  - a. Remove motor mounting bolts. Slide the motor forward and lean on the cart frame.
  - a. Remove the two bolts and access cover plate. See FIG. 19.
  - b. Remove old brushes and install new ones supplied in kit.

9. See instruction sheet 406582, included with Brush Repair Kit 287735.

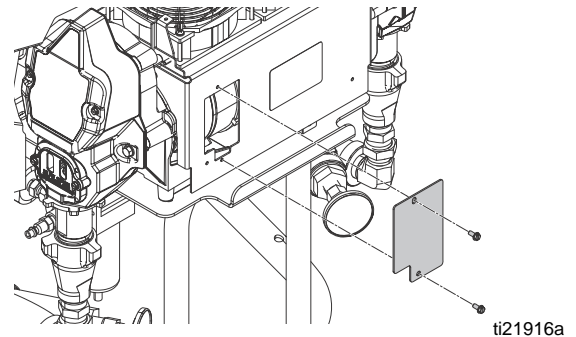

**FIG. 19: Motor Brushes**

## Fans

1. Disconnect fan cable (80) from fan (16). With Motor Power on, test cable connector for line voltage (120 V or 230 V).
2. *If voltage is 120 V or 230 V*, fan is defective. Remove screws holding fan to shield (17). Install new fan in reverse order.
3. *If voltage is not 120 V or 230 V*, check fan cable connection at terminal blocks 1 and 2; see **Cable and Wire Identification**, page 75.

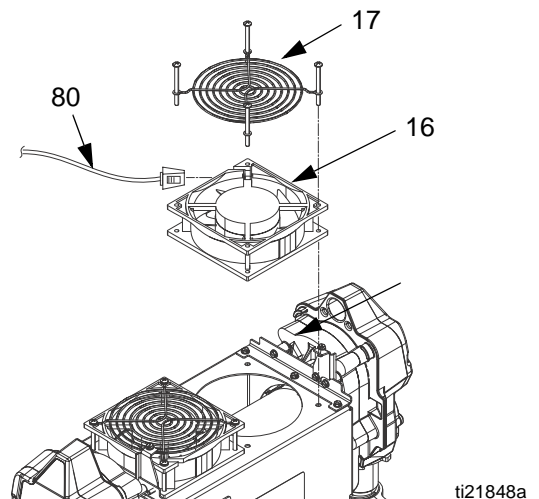

**FIG. 20: Fans**

## Tank Fluid Level Sensors

### Adjust

Adjust position of tank fluid level sensor (57) so that the sensor contacts the surface of the tank.

1. Loosen sensor jam nuts and press sensor (57) against the tank.
2. Spin on inner jam nut until flush, then tighten inner jam nut one more turn.
3. Retighten outer jam nut.

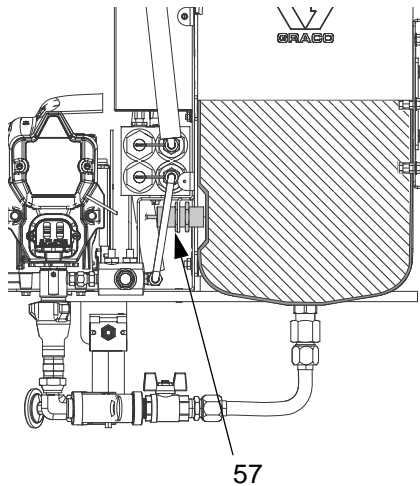

### Replace

1. Loosen jam nuts and remove level sensor assembly (57).
2. Remove supply tank, see page 40.
3. Cut zip ties securing the sensor cable to the cart.
4. Remove the display control cover (26).

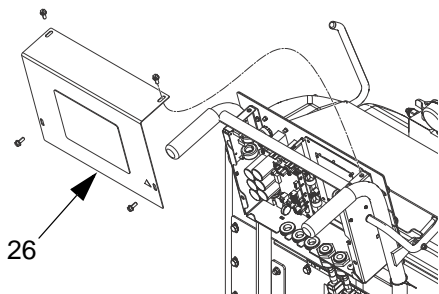

5. Disconnect level sensor connector from J6 on control board. See FIG. 12, page 46.

6. Route new tank level sensor cable through grommet on bottom of cart and through the grommet on bottom of control panel. Connect new level sensor (57) to J6.
7. Install the display control cover (26).
8. Zip tie tank level sensor cable with other low voltage cables.
9. Reinstall supply tank. See page 40.
10. Adjust position of level sensor assembly (57). See **Adjust**.
11. Set sensitivity. See **Reset Sensitivity**, page 57.
12. Check operation of both sensors.
  - a. Hold one hand inside both tanks for 5 seconds, near inner wall, where the tank level sensor is located.
  - b. The tank level indicator LED on the control panel will stop flashing when it senses both of your hands.
  - c. The tank level indicator LED will flash if either tank sensor indicates that it is low. Alternately, remove each hand away from inner wall for 5 seconds. The tank level indicator LED on the control panel will flash.

**Table 12: Sensor LED Identification**

LED	Status
Green - on	Sensor is powered
Green - off	Sensor is not powered
Yellow - on	Sensor detects material (immediate, no 5 second display)
Yellow - off	Sensor does not detect material

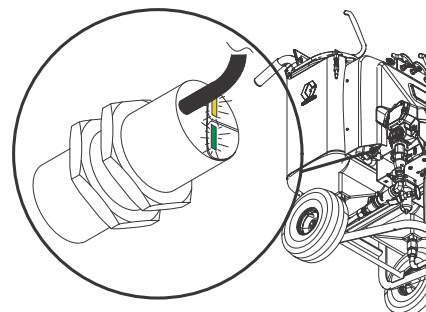

**FIG. 21: Sensor LEDs**



## Reset Sensitivity

The tank fluid level sensor sensitivity may need to be adjusted when:

- A new tank has a different insulation density than the previous tank.
- Material build-up is on the inside or outside of the tank. Adjust sensitivity rather than thoroughly cleaning the tank.
- Level sensor sensitivity comes out of alignment through misuse or harsh environment.
- Material density is less than normally pumped materials.

1. Ensure tank is completely empty.
2. Remove shroud (89) to expose the sensors.
3. Ensure sensor (57) and tank are properly installed. See **Adjust**, page 56.
4. Locate the adjustment screw (S) above the green and yellow LEDs.

**NOTE:** The adjustment screw on some tank level sensors is covered by white tape. Remove the white tape to access the adjustment screw.

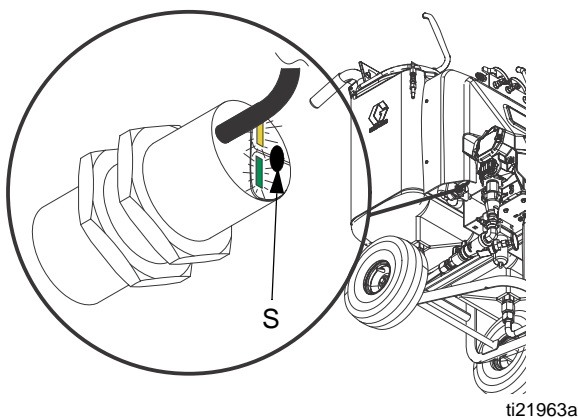

ti21963a

**FIG. 22: Adjustment Screw**

5. Use a small flathead screwdriver and slowly turn the adjustment screw (S) clockwise until the yellow LED turns on.
6. Slowly turn the adjustment screw (S) counterclockwise until the yellow LED barely turns off.

7. Slowly turn the adjustment screw (S) counterclockwise an additional 1/2 turn.

**NOTE:** The yellow LED should stay turned off.

8. Fill tank with desired material and verify that sensor detects material. The yellow LED will turn on when material reaches the one gallon mark.

If the yellow LED does not turn on after two gallons of the material, then the material density may be too low and is not detected by the sensor. Turn the adjustment screw clockwise in 1/8 turn increments until sensor detects the material and the yellow LED turns on.

**NOTE:** If the adjustment screw is turned a total 1/2 turn, then it will not detect an empty tank.

9. Reinstall the shroud (89).

# Parts

## System Packages

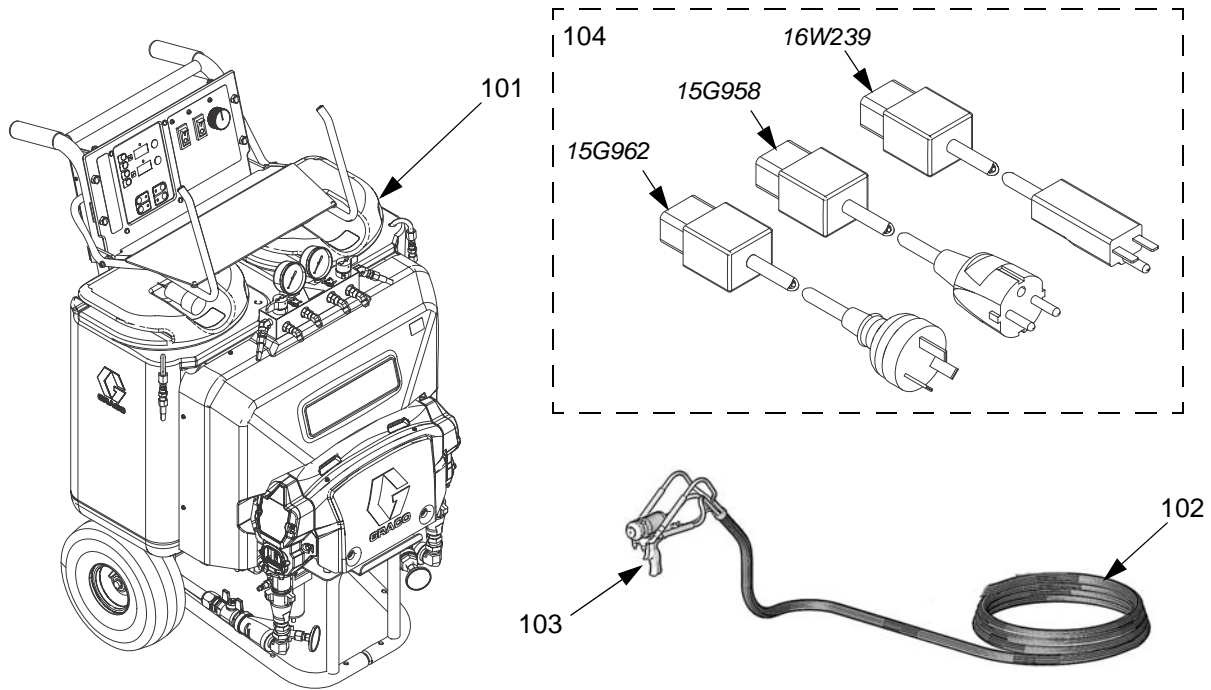

System Package	Proportioner	Hose	Gun	Power Cord Adapter	
	101 see page 59	102 see page 72	103	104	
				Part No.	Region
APT100	24T100	25R000	249810	✘	✘
P2T100	24T100	25R000	GCP2RA*	✘	✘
APT900	24R900	25R000	249810	16W239	North America
APT901	24R900	25R000	249810	15G958	Europe
APT902	24R900	25R000	249810	15G962	Australia/Asia
P2T900	24R900	25R000	GCP2RA*	16W239	North America
P2T901	24R900	25R000	GCP2RA*	15G958	Europe
P2T902	24R900	25R000	GCP2RA*	15G962	Australia/Asia

\* Probler packages use recirc accessory kit 24E727.

✘ Not included.

# E-10hp Proportioners

24T100, 120 V, Proportioner  
24R900, 230 V, Proportioner

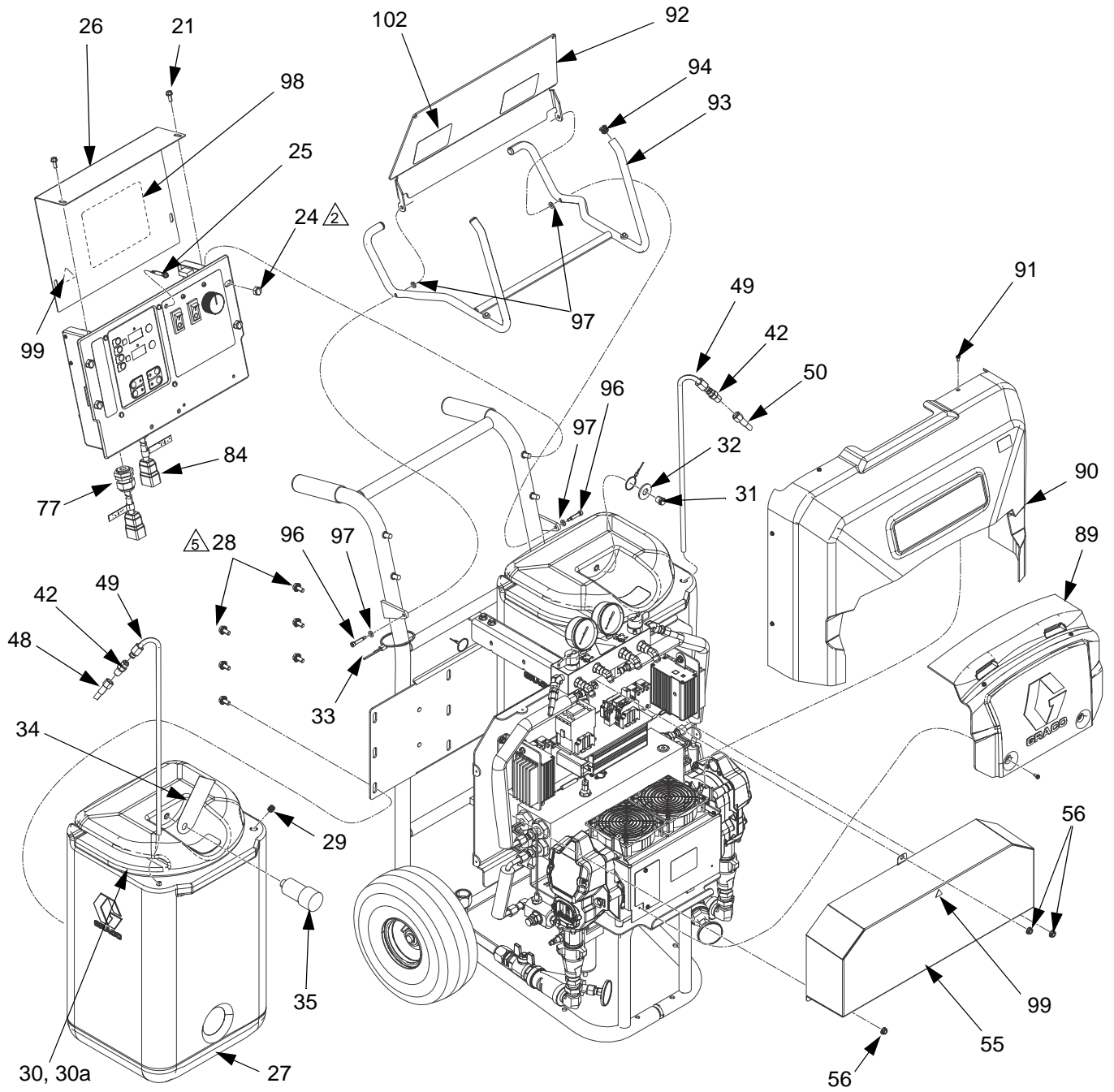

ti21853a

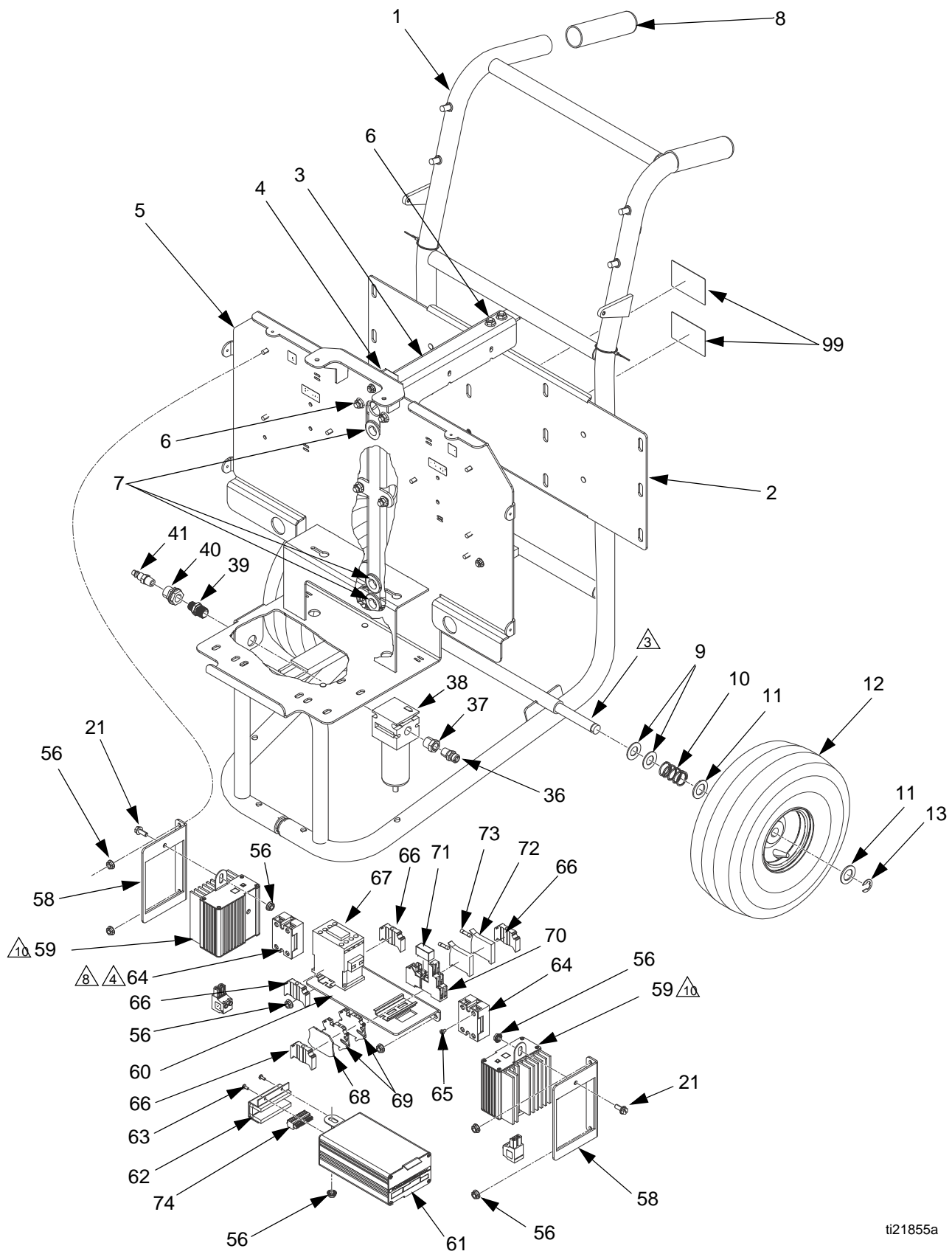

ti21855a

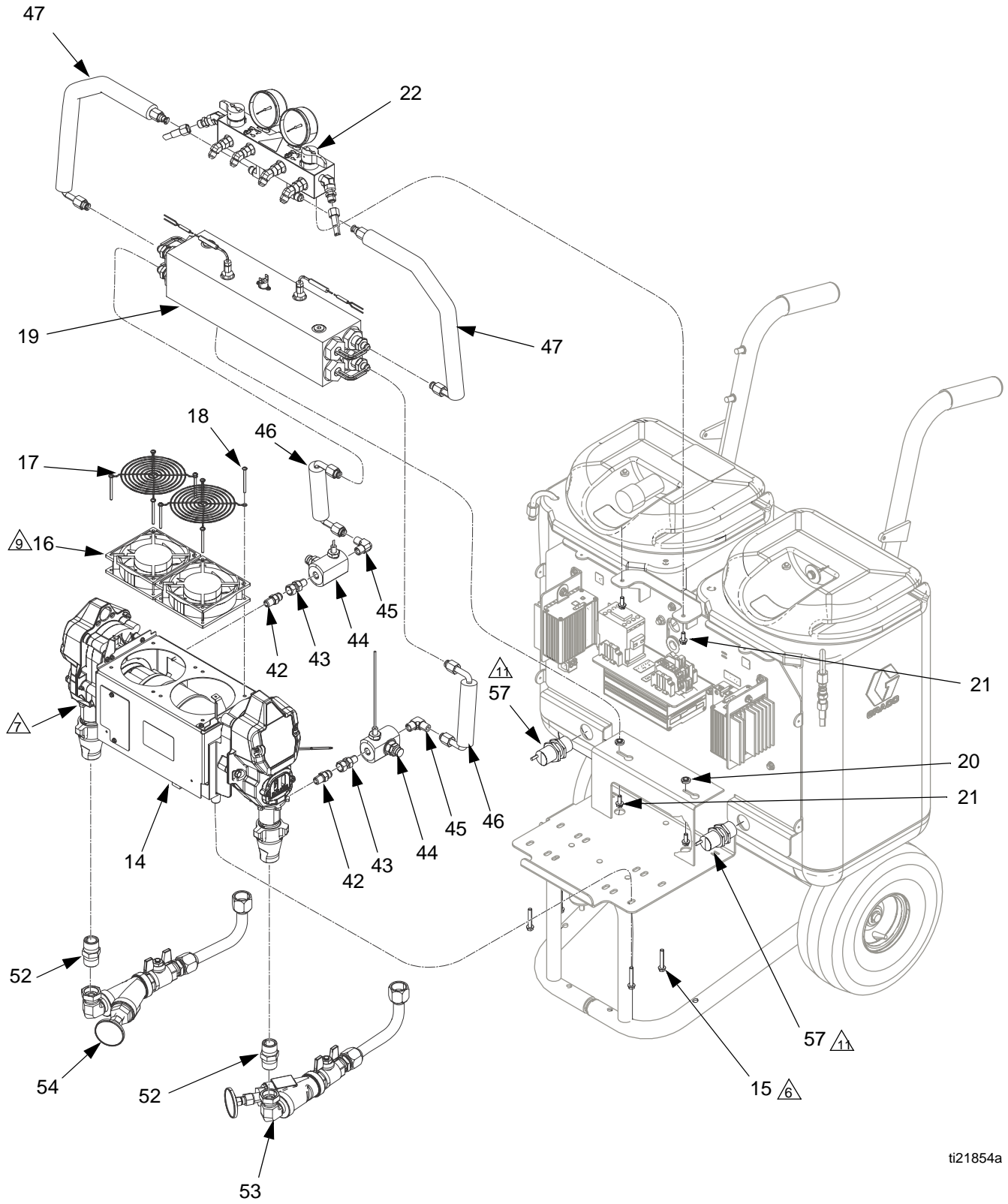

ti21854a

Parts

- △ Apply sealant to all non-swiveling pipe threads.
- △ Apply sealant to threads of nut cap.
- △ Apply lubricant to thread and axle of cart.
- △ Apply even distribution of thermal grease on bottom of metal surface of solid state relays.
- △ Torque to 125 in.-lbs (14 N•m).
- △ Torque to 150 in.-lbs (17 N•m).
- △ Assemble nut to finger tight only.
- △ Orient SSR with terminals 1 and 2 towards the top.
- △ Orient fan to flow down and connector plug towards the back.
- △ Orient heater module with fins outwards.
- △ Assemble sensor flush to tank surface.
- △ Install clamp-on ferrite near termination of transducer wires. See FIG. 25, page 77.
- △ Install clamp-on ferrite on black and red motor power wires. See FIG. 25, page 77.

**24T100, 120 V, Proportioner**  
**24R900, 230 V, Proportioner**

Ref.	Part	Description	Quantity	
			24T100, 120 V	24R900, 230 V
1	---	CART	1	1
2	24T950	BRACKET, tank mount	1	1
3	24T951	BRACKET, crossbar	1	1
4	24T952	BRACKET, gusset, cart	1	1
5	24T953	BRACKET, motor mount	1	1
6	110996	NUT, hex, flange head	18	18
7	101765	GROMMET	3	3
8	119975	GRIP, vinyl, gray; 1.25 in.	2	2
9	154636	WASHER, flat	4	4
10	116411	SPRING, compression	2	2
11	116477	WASHER, flat, nylon	4	4
12	116478	WHEEL, pneumatic	2	2
13	101242	RING, retaining, ext.	2	2
14	24T954	PROPORTIONER, see page 66	1	1
15	117493	SCREW, mach, hex washer hd; 1/4-20	4	4
16	24K985	FAN, cooling, 120 VAC	2	
	24K986	FAN, cooling, 230 V		2
17	115836	GUARD, finger	2	2
18	120094	SCREW, pan hd, phil, zinc	8	8
19	24U009	HEATER, assy; 120V, 1000W; see page 68	1	
	24T955	HEATER, assy; see page 68		1
20	167002	INSULATOR, heat	2	2
21	108296	SCREW, mach, hex wash hd	10	10
22	24T960	MANIFOLD, outlet/recirc; see page 71	1	1
23	24T962	DISPLAY, control; see page 69	1	1
24	117623	NUT, cap; 3/8-16	4	4
25	24U005	DIODE, light-emitting, 120 V	1	
	24T970	DIODE, light-emitting, 230 V		1
26	24R648	COVER, display	1	1

Ref.	Part	Description	Quantity	
			24T100, 120 V	24R900, 230 V
27	24T973	TANK	2	2
28	111800	SCREW, cap, hex hd	12	12
29	127148	SCREW, set, 7/16-14, 1/2, black	2	2
30	24T975	LID; includes o-ring (30a)	2	2
30a	24T975	O-RING	2	2
31	24K976	MUFFLER, 1/4 NPT	1	1
32	101044	WASHER, plain	1	1
33	119973	CABLE, sst lanyard; 14 in.	2	2
34▲	15X466	TAG, instruction, desiccant	1	1
35	24K984	DRYER, desiccant, mini in-line	1	1
36	162453	FITTING; 1/4 npsm x 1/4 npt	1	1
37	100176	BUSHING, hex	1	1
38	24K977	FILTER, regulator, air; with 3/8 npt auto drain; includes 64a	1	1
38a	114228	ELEMENT, 5 micron; polypropylene; not shown	1	1
39	157350	ADAPTER	1	1
40	104641	FITTING, bulkhead	1	1
41	169970	FITTING, line air; 1/4-18 npt	1	1
42	116704	ADAPTER, 9/16-18 JIC x 1/4 NPT	4	4
43	117506	FITTING, swivel, 1/4 npt x #6 JIC	2	2
44	---	MANIFOLD, assembly, outlet; see page 72	2	2
45	556765	FITTING, #6 JIC 1/4PM	2	2
46	24T977	TUBE, pump outlet, ISO	2	2
47	24T978	TUBE, heater outlet, ISO	2	2
48	24T979	HOSE, coupled, recirc, ISO	1	1
49	24T980	TUBE, recirculation	2	2
50	24T981	HOSE, coupled, recirc, RES	1	1

## Parts

Ref.	Part	Description	Quantity	
			24T100, 120 V	24R900, 230 V
51	114225	TRIM, edge protection	1	1
52	119992	FITTING, pipe, nipple, 3/4 x 3/4 npt	2	2
53	24T982	MANIFOLD, inlet, RES; see page 70	1	1
54	24T986	MANIFOLD, inlet, ISO; see page 70	1	1
55	24T987	COVER, electronics	1	1
56	115942	NUT, hex, flange head	12	12
57	24T988	SENSOR, tank level	2	2
58	24T990	PANEL, heater control mount	2	2
59	247828	MODULE, heater	2	2
60	24T989	PANEL, logic control mount	1	1
61	24T308	MODULE, heater control, 120 V	1	
	24T307	MODULE, heater control, 230V		1
62	255053	COVER, connector, pod	1	1
63	114331	SCREW, mach, pnh, sems	2	2
64	24U006	RELAY, SSR, 120 V	2	
	24T991	RELAY, SSR, 230 V		2
65	112144	SCREW, mach, pan hd	4	4
66	126811	BLOCK, clamp end	4	4
67	24U007	CONNECTOR, contactor; 120 V	1	
	24T992	CONNECTOR, contactor; 230 V		1
68	126817	COVER, end	1	1
69	126818	BLOCK, terminal 3-wire	2	2
70	126810	RELAY, cradle	1	1



Ref.	Part	Description	Quantity	
			24T100, 120 V	24R900, 230 V
71	24T993	RELAY, 12V	1	1
72	255043	HOLDER, fuse terminal block; 5 x 20mm	2	2
73	120712	FUSE, 5A, 5 x 20 mm	2	2
74†	127239	CONNECTOR, 5 pin	1	
	127240	CONNECTOR, 10 pin		1
75†	127238	CONNECTOR, 2 pin	2	1
76	127237	CONNECTOR, 6 pin	1	1
77	116171	BUSHING, strain relief	2	
	16W761	BUSHING, strain relief		2
78✘†	24T994	HARNESS, POWER; see page 73	1	1
79✘†	24T995	CABLE, communication, heater control module	1	1
80✘†	24T996	CABLE, FAN, 29 in. (736.6 mm)	2	2
81✘†	24T997	CABLE, control, display	1	1
82✘†	24T998	CABLE, harness, overtemperature	1	1
83	24T999	CONNECTOR, jumper	2	2
84	24U008	CORD, 20A, 120 V	2	
	24U000	CORD, 16A, 230 V		2
85	113505	NUT, keps, hex hd	2	2
86	16W309	LABEL, identification, multi	1	1
87	15W625	LABEL, cord	1	1
88✘†	125835	CLIP, ferrite bead	2	2
89	24U001	COVER, proportioner, lower	1	1
90	24U002	COVER, proportioner, upper	1	1
91	115492	SCREW, mach, slot hex wash hd	10	10
92	24U003	GUARD, splash, hose rack	1	1
93	24U004	RACK, hose	1	1
94	120008	PLUG, tube	4	4
95	120150	ISOLATOR, pad, rubber	2	2
96	119999	BOLT, shoulder	2	2
97	110533	WASHER, flat, nylon, 1/4	4	4
98▲	15G280	LABEL, safety, warning, multiple	1	1
99▲	189930	LABEL, electric shock	2	2
104	217374	LUBRICANT, ISO pump	1	1

▲ Replacement Danger and Warning labels, tags, and cards are available at no cost.

✘ Not shown.

† See **Electrical Wiring Identification**, page 73.

--- Not available for purchase.

## 24T954, 120 V and 230 V Bare Proportioner

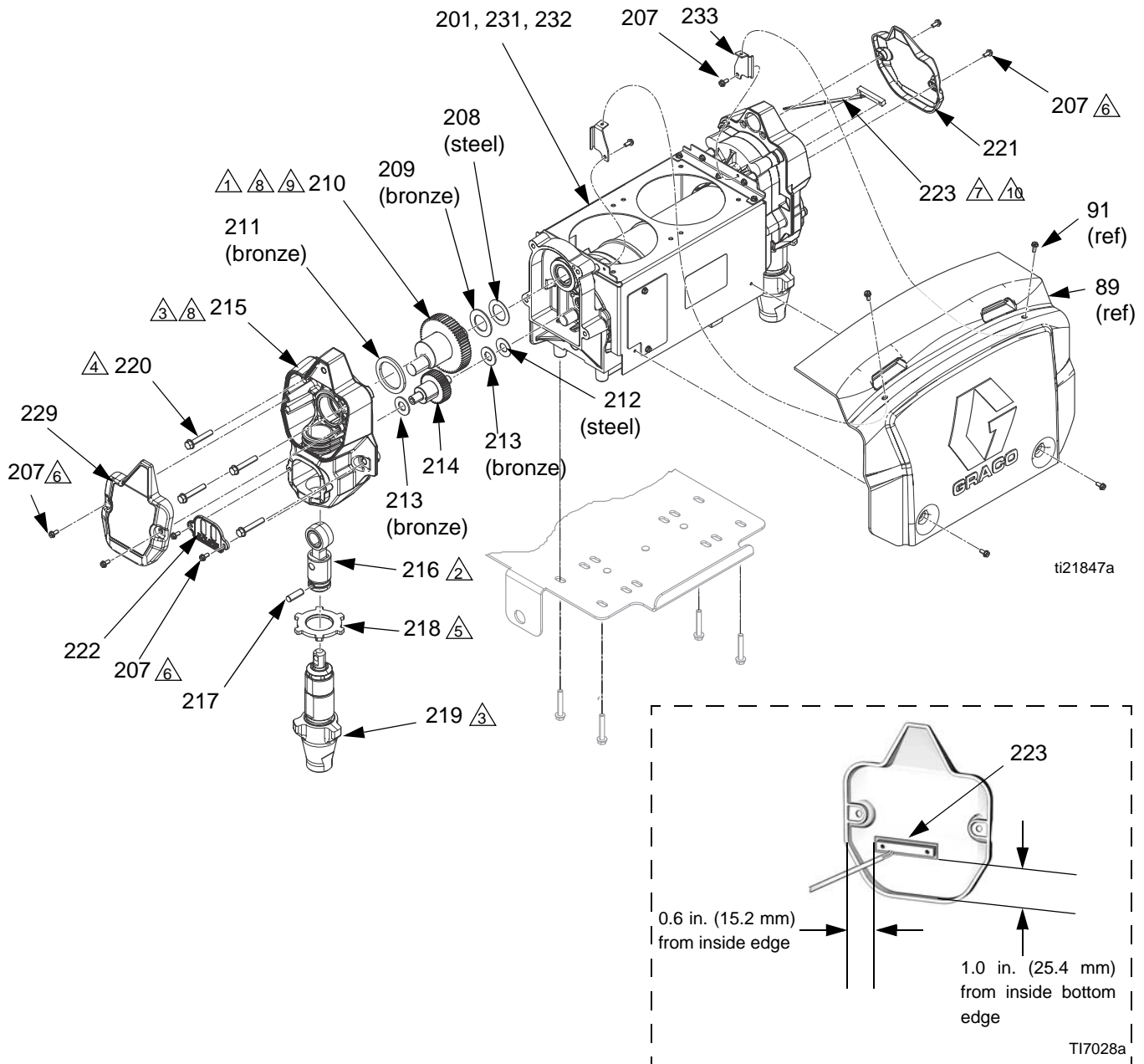

- ① Apply lubricant to all gear teeth, motor pinion, and motor endbell on both sides of motor.
- ② Apply lubricant to rectangular cavity on connecting link.
- ③ Apply lubricant to threads of pump cylinder before assembly into housing. Align top of cylinder flush within 0.06 to inside bottom of pump mounting hole.
- ④ Torque fasteners to 140-160 in.-lbs (15-18 N•m).
- ⑤ Assemble nut to finger tight only.

- ⑥ Torque fasteners to 30-35 in.-lbs. Applies only when fasteners are assembled in plastic housings (215).
- ⑦ Switch mounts to cover opposite brush end of motor only.
- ⑧ Housing must be installed on motor with crankshafts aligned with each other.
- ⑨ Assemble magnet to center of offset crankshaft on switch cover side of motor and adjust for park location.
- ⑩ Affix switch to motor cover with double-sided tape. Cut to 2 in. (50.8 mm). Mount cover on side opposite brush end of motor.

Ref.	Part	Description	Qty
201	24T758	MOTOR, electric	1
207‡	115492	SCREW, mach, slot hex wash hd	10
208*	116074	WASHER, thrust	2
209*	107434	BEARING, thrust	2
210*	300001	KIT, crankshaft	2
211*	180131	BEARING, thrust	2
212‡	116073	WASHER, thrust	2
213‡	116079	BEARING, thrust	4
214‡	243980	GEAR, reducer (first stage)	2
215‡	287000	HOUSING, drive	2
216	287053	KIT, repair, connecting, rod	2
217◆	196762	PIN, straight	2
218	195150	NUT, jam, pump	2
219	24L006	PUMP, displacement	2
220‡	117493	SCREW, mach, hex washer hd	8
221‡	300002	KIT, cover; includes switch	1
222‡	15B589	COVER, pump rod	2
223	117770	SWITCH, reed with cable	1
224	119875	MAGNET, disc, 0.38 dia., 0.100 thick; not shown	1
227	115711	TAPE, foam, 1/2 wide	1
229	300003	KIT, cover	1
231	15F591	HOUSING, motor	1
232	15G415	HOUSING, motor, threaded	1
233	16W162	BRACKET, shroud tab	2

\* Included in 300001 Crankshaft Kit (210).

‡ Included in 244242 Gear Reducer Kit.

‡ Included in 287055 Drive Housing Kit.

◆ Included in 287053 Connecting Rod Kit.

# 24U009, 120 V Heater 24T955, 230 V Heater

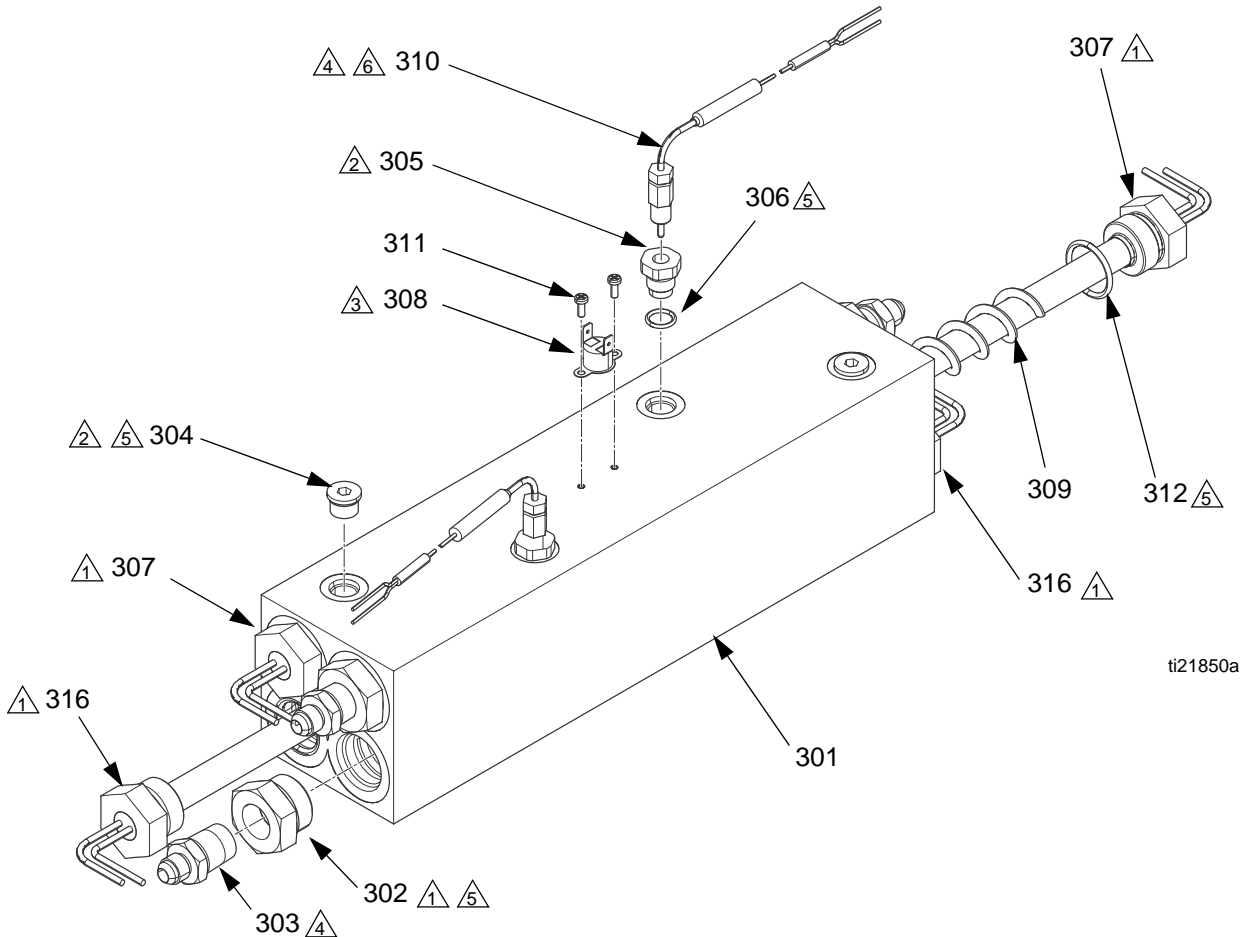

ti21850a

- ⚠1 Torque to 120 ft-lbs (163 N•m).
- ⚠2 Torque to 23 ft-lbs (31 N•m).
- ⚠3 Apply 110009 thermal heat sink compound.
- ⚠4 Apply sealant and tape to all non-swiveling and threads without o-rings.
- ⚠5 Apply lubricant to o-rings before assembling in heater housing.
- ⚠6 Tighten NPT fitting from sensor to heater housing as shown. Remove tape from probe tip prior to inserting. Insert probe until tip bottoms on heater element. Tip must touch heating element. Insert ferrule and tighten ferrule nut to sensor probe. Orient sensor as shown and torque 1/4 turn past tight.

Ref.	Part	Description	Qty.	Ref.	Part	Description	Qty.
301	24T956	BLOCK, heater	1	308	15B137	SWITCH, overtemperature	1
302	15H302	FITTING, reducer 1-3/16 SAE x 1/2 npt	4	309	16U940	MIXER, heater	4
303	16V432	FITTING, adapter, #6 JIC x npt, mxm	4	310	117484	SENSOR,	2
304	15H304	FITTING, plug, 9/16 SAE	2	311	124131	SCREW, mach, pnhd; #6-32	2
305	15H306	ADAPTER, thermocouple, 9/16 x 1/8	2	312	124132	O-RING	4
306	120336	O-RING, packing	2	316	24T959	HEATER, fire rod, 230 V; 24T955 only	2
307	24T958	HEATER, fire rod, 230 V, 24R340 only	2		24U014	HEATER, fire rod, 120 V; 24U009 only	2
	24U012	HEATER, fire rod, 120 V, 24R979 only	2				

## 24T962, Display

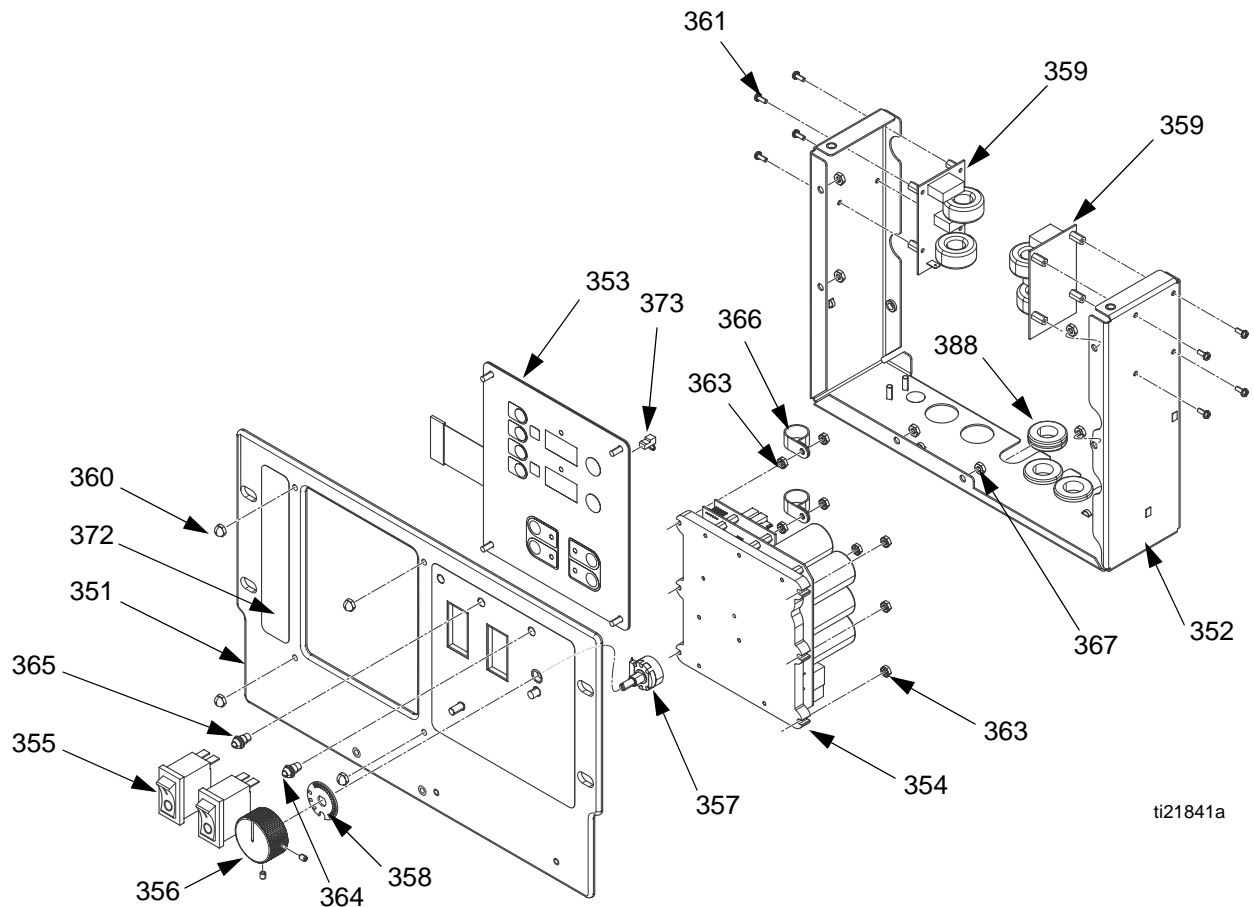

ti21841a

Ref.	Part	Description	Qty.	Ref.	Part	Description	Qty.
351	24T963	PLATE, display, front	1	366	122688	CLAMP, cable	2
352	24T964	ENCLOSURE, control	1	367	113505	NUT, keps, hex hd	6
353	24T966	DISPLAY, heat two zone	1	368	101765	GROMMET	3
354	24T967	CONTROL, board, assy	1	372	16V804	LABEL, instructions	1
355	24K983	SWITCH, rocker, w/breaker, 240v, 20a	2	373	127019	CONNECTOR, jumper, e-stop	1
356	24L001	KNOB, control, w/ball plunger	1			---	Not available for purchase.
357	24L002	POTENTIOMETR, adjustment, pressure	1				
358	15G053	PLATE, detent, display	1				
359	248219	FILTER, board	2				
360	117523	NUT, cap (#10)	4				
361	127157	SCREW, mach, captive, #8	8				
363	127158	NUT, captive, #8	8				
364	24T968	DIODE, light-emitting, red	1				
365	24T971	DIODE, light-emitting, yellow	1				

## Fluid Inlets

24T986, ISO Inlet  
24T982, RES Inlet

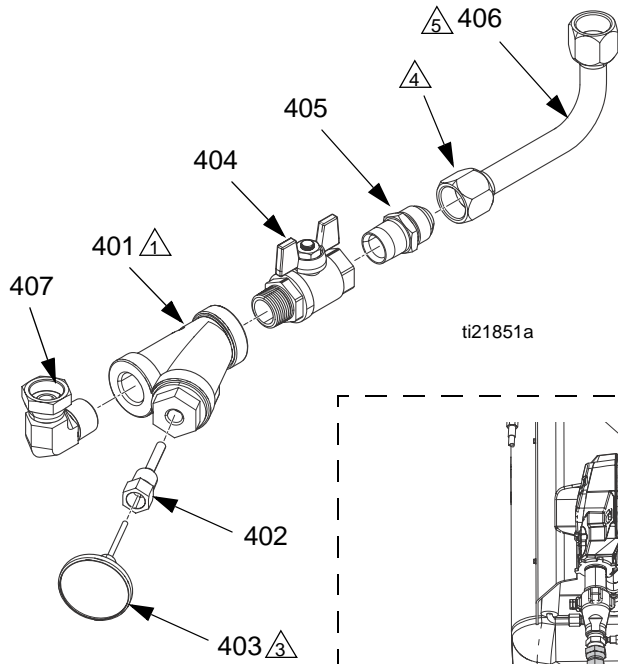

- ① Align Y-strainer as shown
- ② Apply sealant to all npt threads. Do not apply to JIC threads.
- ③ Apply thermal lubricant to thermometer probe.
- ④ Torque fitting of bent tube to 45-50 ft-lbs (61-67 N•m).
- ⑤ Align bent tube to fitting within 2°.
- ⑥ Align thermometer dial as shown.

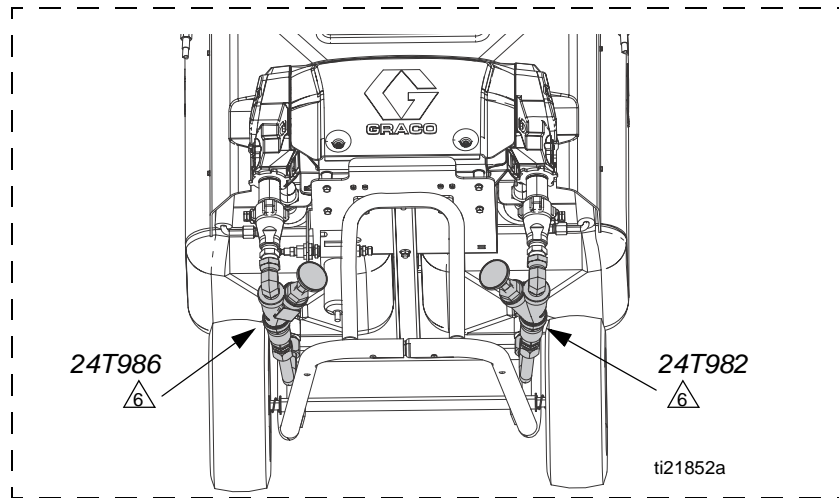

Ref. Part	Description	Qty.
401	101078 STRAINER, Y	1
402	15D757 HOUSING, thermometer, Viscon HP	1
403	102124 THERMOMETER, dial	1
404	24T983 VALVE, ball, 3/4 npt, mxf, T-handle	1
405	24T984 FITTING, adapter JIC-12 X 3/4 npt, mxm	1
406	24T985 TUBE, assy, inlet	1
407	160327 FITTING, union adapter, 90°	1

# 24T960, Fluid Manifold

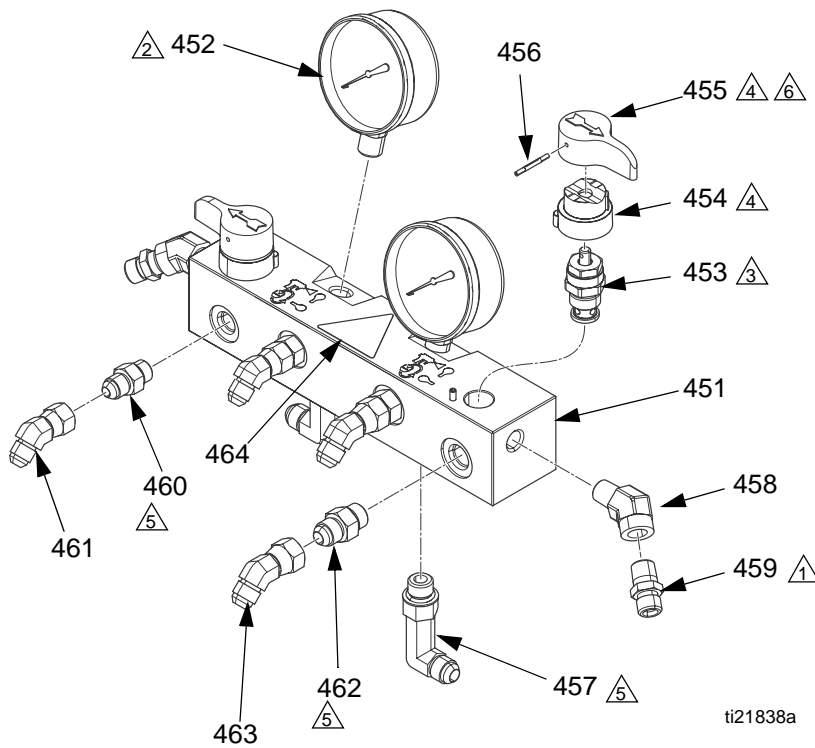

- ▲1 Apply sealant to assembled non-swiveling pipe threads.
- ▲2 Apply sealant and PTFE tape to threads.
- ▲3 Apply sealant to valve threads. Torque to 240-260 in.-lbs (27-29 N•m).
- ▲4 Apply lubricant to mating surfaces of valve base and handle.
- ▲5 Apply lubricant to o-rings on fittings. Torque to 16-20 ft-lbs (22-27 N•m).
- ▲6 Align handles as shown when open.

ti21838a

Ref.	Part	Description	Qty.	Ref.	Part	Description	Qty.
451	24T961	MANIFOLD, fluid	1	460	127130	FITTING, straight, JIC-5 x SAE-ORB	2
452	102814	GAUGE, pressure, fluid	2	461	127128	FITTING, 45° elbow, JIC-5, mxf, swivel	2
453	239914	VALVE, drain	2	462	127131	FITTING, straight, JIC-6 x SAE-ORB	2
453a	15E022	SEAT	1	463	127129	FITTING, 45° elbow, JIC-6, mxf, SWIVEL	2
453b	111699	GASKET	1	464▲	189285	LABEL, warning, hot surface	1
454	224807	BASE, valve	2	▲ Replacement Danger and Warning labels, tags, and cards are available at no cost.			
455	187625	HANDLE, valve, drain	2				
456	111600	PIN, grooved	2				
457	16V434	FITTING, 90 elbow, JIC-6 x SAE-ORB	2				
458	119789	FITTING, elbow, street, 45°	2				
459	162453	FITTING; 1/4 npsm x 1/4 npt	2				

## 25R000, Insulated Hose Bundle with Recirculation Lines

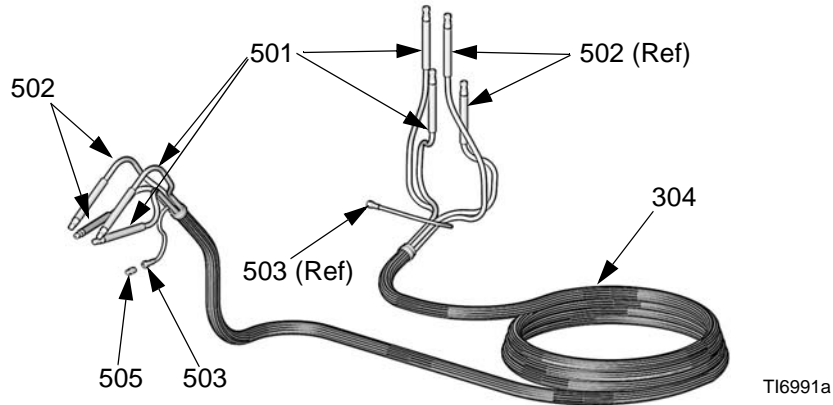

Ref.	Part	Description	Qty	Ref.	Part	Description	Qty
501	24R996	HOSE, fluid (component ISO), moisture guard; 1/4 in. (6 mm) ID; no. 5 JIC fittings (mxf); 35 ft (10.7 m)	2	503	15G342	HOSE, air; 1/4 in. (6 mm) ID; 1/4 npsm (fbe); 35 ft (10.7 m)	1
502	24R997	HOSE, fluid (component RES); 1/4 in. (6 mm) ID; no. 6 JIC fittings (mxf); 35 ft (10.7 m)	2	504	buy locally	TUBE, foam, insulated; 1-3/8 in. (35 mm) ID; 31 ft (9.5 m)	1
				505	156971	NIPPLE; 1/4 npt; for joining air line to another hose bundle	1

## Outlet Manifold

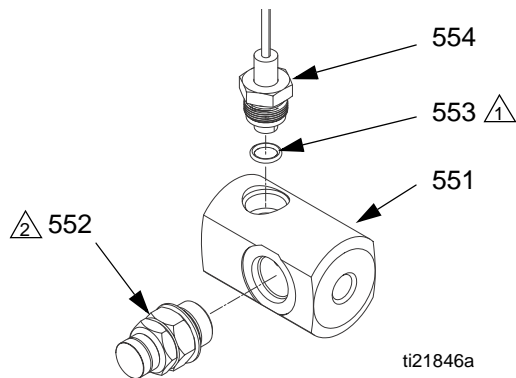

⚠️ Apply lubricant to o-rings.

⚠️ Orient housing with exhaust hole pointing down.

Ref.	Part	Description	Qty
551	24T976	MANIFOLD, fluid, pump, outlet	1
552	15M178	HOUSING, rupture disc	1
553	111457	PACKING, o-ring	1
554	246123	TRANSDUCER, pressure, control	1



# Electrical Wiring Identification

Use the tables to identify cable or wire harness references and system component connections. See **Power Harness**, page 73 and **Cable and Wire Identification**, page 75.

## Power Harness

**NOTE:** Only power harness (78) has wire labels. See FIG. 23, page 74.

Ref.	Terminal 1			Terminal 2		
	Connector	Type	Location	Connector	Type	Location
<b>Power Harness (78)</b>						
H01	---	Quick Disconnect	Heater Filter T4	---	Ferrule	Contactora L1
H02	---	Quick Disconnect With Lead	Motor Filter T3	---	Double Ferrule	Relay Com
H03	---	Quick Disconnect With Lead	Motor Filter T4	---	Ferrule	Contactora L3
H04	---	Quick Disconnect	Heater Filter T3	---	Ferrule	Contactora L2
H05	---	Quick Disconnect	Boost Light Terminal 1	---	Ferrule	Contactora L4
H06	---	Quick Disconnect	Boost Light Terminal 2	---	Ferrule	Contactora T3
H11	J4	Molex Pin	Control Board J8 pin 1	---	Ferrule	Relay A1
H12	J4	Molex Pin	Control Board J8 pin 2	---	Ferrule	Relay A2
H13	J1	Ferrule	Heater Control Module - Pin 1 Power	---	Double Ferrule	F2 Load
H14	J1	Ferrule	Heater Control Module - Pin 2 Power	---	Ferrule	F1 Load
H15	J1	Ferrule	Heater Control Module - Pin 3 CN Coil	---	Ferrule	Contactora A2
H16	J1	Ferrule	Heater Control Module - Pin 4 CN Coil	---	Ferrule	Contactora A1
H17	J2	Ferrule	RES Pod Power Connector - Pin 1	---	Ferrule	Contactora T1
H18	J3	Ferrule	ISO Pod Power Connector - Pin 1	---	Ferrule	Contactora T1
H19	J3	Ferrule	ISO Pod Power Connector - Pin 2	---	Ferrule	SSR1 T3
H20	J2	Ferrule	RES Pod Power Connector - Pin 2	---	Ferrule	SSR2 T3
H21	---	Ferrule	Contactora L3	---	Ferrule	T1 Line
H22	---	Ferrule	SSR1 T1	---	Ferrule	Contactora T3
H23	---	Ferrule	SSR1 T4	---	Ferrule	SSR2 T4
H24	---	Ferrule	SSR1 T1	---	Ferrule	SSR2 T1
H25	---	Ferrule	Contactora L1	---	Ferrule	F1 Line
H26	---	Ferrule	Contactora L2	---	Ferrule	F2 Line
H27	---	Double Ferrule	Relay Com	---	Ferrule	T2 Line
H28	---	Ferrule	Contactora L4	---	Short Ferrule	Relay No
H29	---	Ferrule	SSR2 T4	---	Double Ferrule	F2 Load
J1	J1	4 Pin Connector	Heater Control Module	---	---	---
J2	J2	2 Pin Connector	Blue Pod	---	---	---
J3	J3	2 Pin Connector	Blue Pod	---	---	---
J4	J4	2 Pin Connector	Motor Control Board	---	---	---

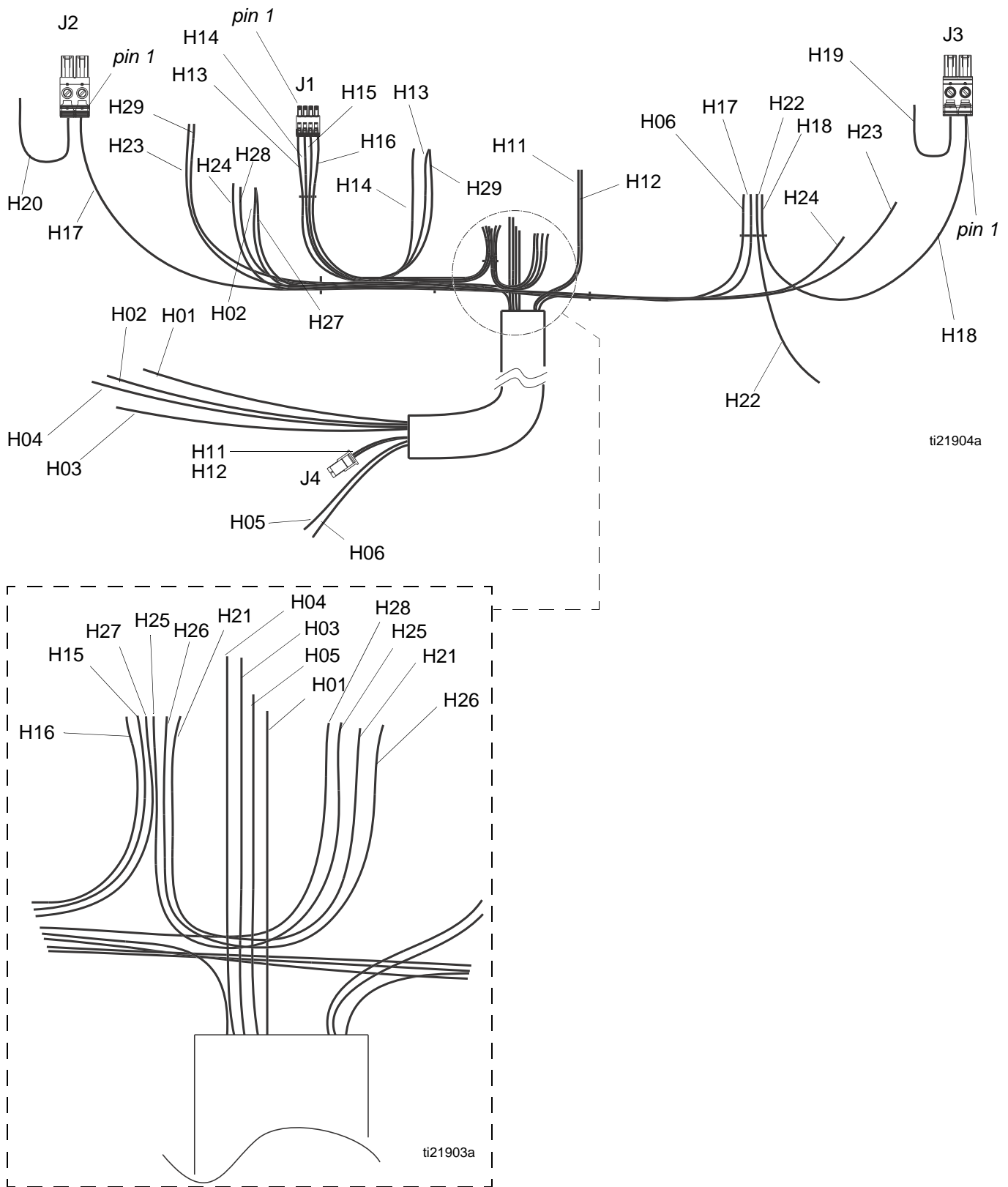

**FIG. 23: Power Harness (78) Wire Identification**

## Cable and Wire Identification

See FIG. 24 and FIG. 25, page 76 and 77.

Ref.	Description	Location
<b>Heater Wires (19)</b>		
W01	ISO Main Heating Rod 1	ISO Heating Module
W02	ISO Main Heating Rod 2	Contactactor T2
W03	ISO Boost Heating Rod 1	ISO SSR T2
W04	ISO Boost Heating Rod 2	Contactactor T4
W05	RES Main Heating Rod 1	RES Heating Module
W06	RES Main Heating Rod 2	Contactactor T2
W07	RES Boost Heating Rod 1	RES SSR T2
W08	RES Boost Heating Rod 2	Contactactor T4
W09	Thermocouple ISO	Connector (74)
W10	Thermocouple RES	Connector (74)
<b>Logic Cable (79)</b>		
C04	Female Socket 2 x 9 pin	Silver Heater Control Module
C05	Female Socket 2 x 3 pin	ISO Heating Module
C06	Female Socket 2 x 3pin	RES Heating Module
<b>Fan Cable (80)</b>		
C07	Flying Leads	Terminal Block 1 and 2
C08	Molded Fan Plug	Fan (16)
<b>Display Cable (81)</b>		
C09		Heater Display
<b>Overtemperature Cable (82)</b>		
C01	Female Quick Disconnect	Heater Overtemp
C02	Female Quick Disconnect	Heater Overtemp
C03	Flying Leads	Connector (74) or (75)
<b>Jumper Cable (83)</b>		
P09	Ferrule	Heater Filter, Heater Switch
P10	Ferrule	Heater Filter, Heater Switch
<b>Power Cord (84)</b>		
G01	Motor, Green Ring	Ground
G02	Heater, Green, Ring	Ground
P01	Motor, Black, Ferrule	Motor Switch
P02	Motor, Tan, Ferrule	Motor Switch
P07	Heater, Black, Ferrule	Heater Switch
P08	Heater, Tan, Ferrule	Heater Switch

Ref.	Description	Location
<b>Connectors</b>		
C10	Analog Switch	Motor control board
C11	Tank Level LED	Motor control board
C12	Error LED	Motor control board
C13	Level Sensors	Motor control board
C14	Motor Overtemp Switch	Motor control board
C15	Reed Sensor	Motor control board
C16	Transducer ISO	Motor control board
C17	Transducer RES	Motor control board
C18	Motor Power	Motor control board

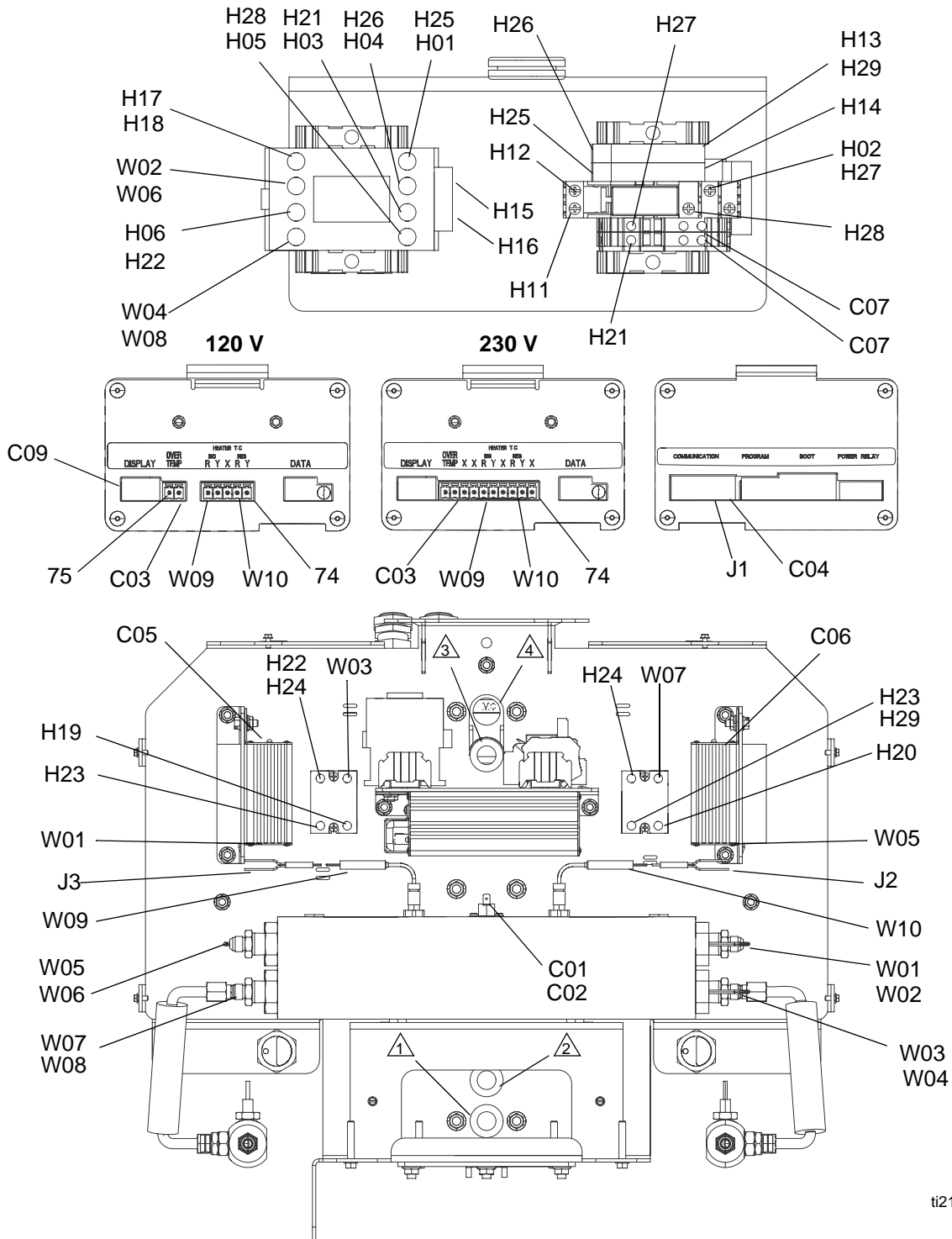

- ⚠ Feed level sensor, transducers, cycle switch, and motor overtemp switch through grommet.
- ⚠ Feed motor power cable through grommet.

- ⚠ Feed heater display harness through grommet.
- ⚠ Feed power harness through hole.

FIG. 24

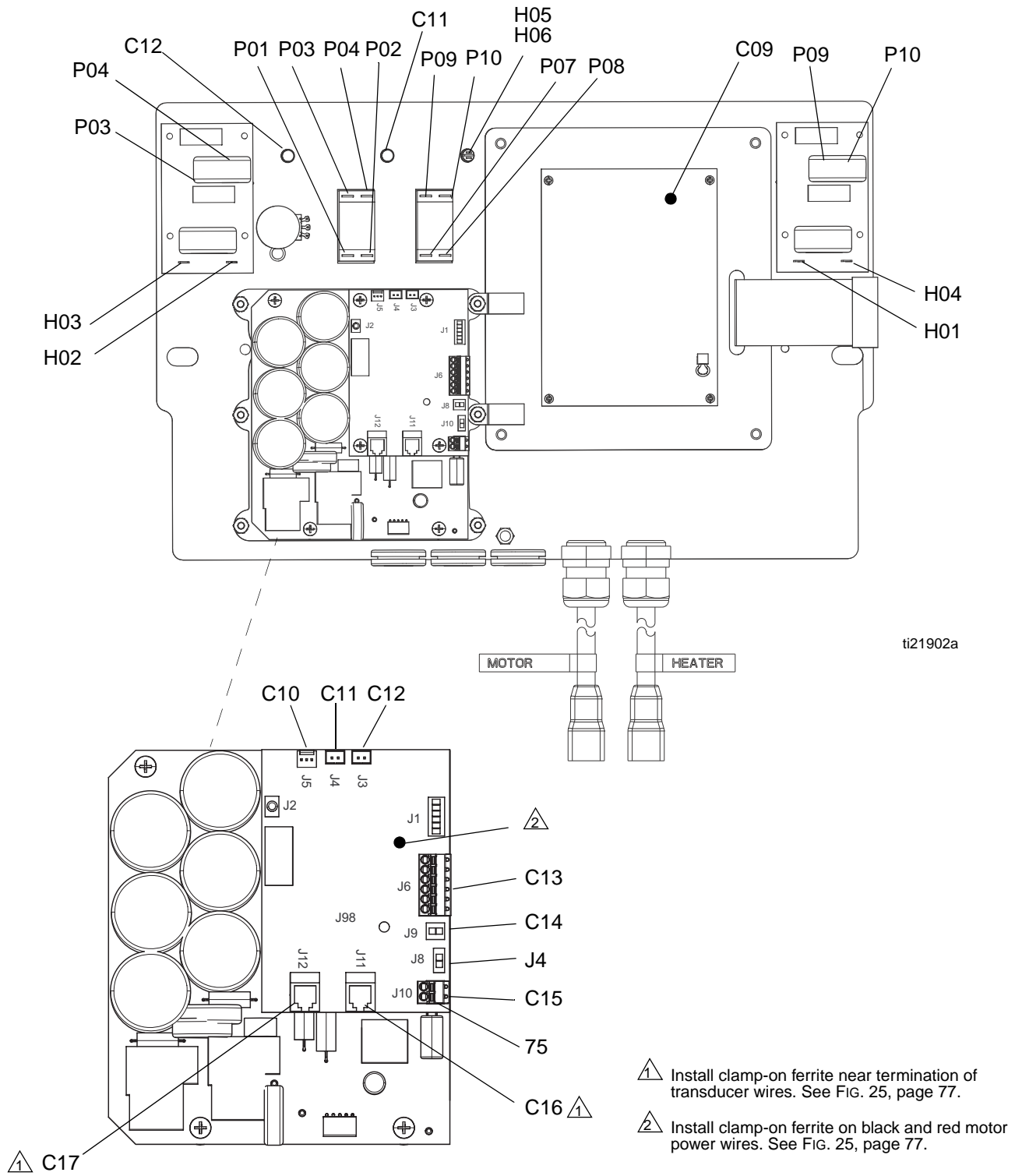

ti21902a

FIG. 25

## Suggested Replacement Parts

Part	Description
24K984	DRYER, desiccant
24K983	SWITCH, motor or heater power, with circuit breaker
101078	Y-STRAINER; includes 180199 element
180199	ELEMENT, Y-strainer, 20 mesh
114228	ELEMENT, air filter, 5 micron; polypropylene
239914	VALVE, recirc/spray; includes seat and gasket
24L002	POTENTIOMETER, control knob
24K999	TRANSDUCER, pressure
24L006	PUMP, displacement; fits either side
249855	REPAIR KIT, displacement pump; includes seals, balls, bearings, intake seat)
24T975	O-RING, tank lid

## Accessories

Part	Description
24E727	Probler Recirc Kit

## Dimensions

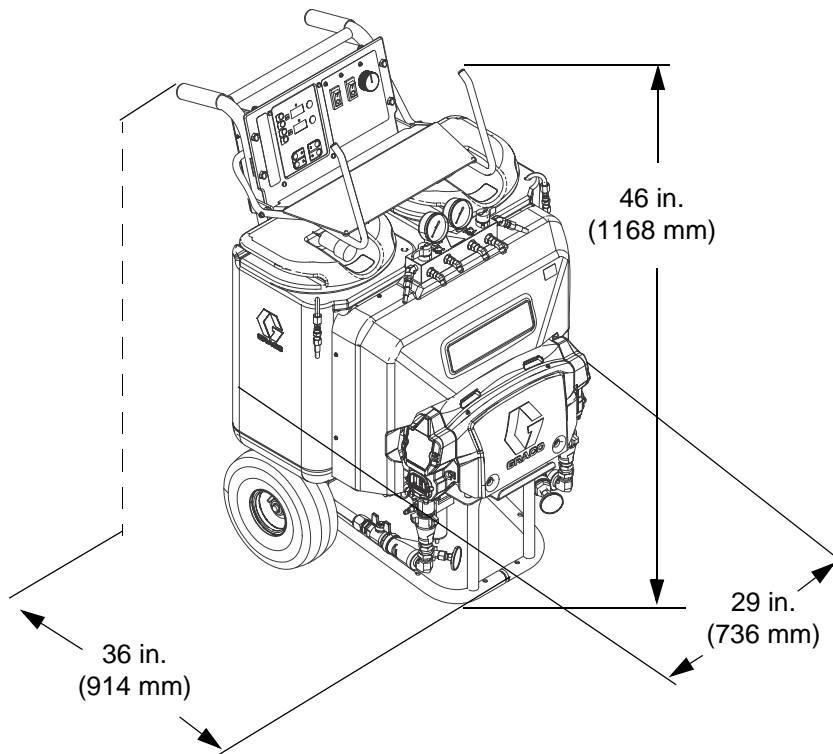

# Technical Data

Reactor E-10hp	US	Metric
Maximum fluid working pressure	3000 psi	20.6 MPa, 206 bar
Maximum spray pressure: 120 V	2200 psi	15.2 MPa, 152 bar
Maximum spray pressure: 230 V	2500 psi	17.2 MPa, 172 bar
Maximum fluid temperature	170°F	77°C
Maximum ambient temperature	120°F	48°C
Maximum output	1 gal./min	3.8 liters/min
Output per cycle (ISO and RES)	0.0038 gallons/cycle	0.014 liters/cycle
Air inlet	1/4 in. quick-disconnect industrial type pin fitting	
Air outlet	1/4 npsm(m)	
Overpressure relief	Recirc/Spray valves automatically relieve excessive fluid pressure back to supply tanks	
Gun compressed air requirements	Fusion Gun (purge air and operating air): 4 scfm (0.112 m <sup>3</sup> /min)	
Maximum hose length	105 ft	32 m
Tank capacity each (nominal)	6 gal.	22.7 liters
Weight (empty)	239 lb	108 kg
<b>Recommended Mix Chamber Sizes</b>		
Fusion <sup>®</sup> Air Purge	000, AW2222 (00 and 01 at reduced spray pressure)	
Probler <sup>®</sup> P2	AA (00 and 01 at reduced spray pressure)	
<b>Electrical Requirements</b>		
120 V	120 VAC, 1 phase, 50/60 Hz, 3840 W; requires two separate, dedicated 20 A circuits. Full load peak amperage 16 A per circuit.	
230 V	230 VAC, 1 phase, 50/60 Hz, 5520 W; requires two separate, dedicated 15 A circuits. Full load peak amperage 12 A per circuit.	
<b>Generator Size</b>		
120 V	5000 W minimum	
230 V	7500 W minimum	
<b>Heater Power</b>		
120 V	3000 W during recirculation, 2000 W during pressure spray mode	
230 V	4000 W during recirculation, 2760 W during pressure spray mode	
<b>Sound Pressure</b>		
In fast recirculation mode	71.3 dB(A)	
Measure at 2500 psi (17 MPa, 172 bar), 1 gpm (3.8 lpm)	85.6 dB(A)	
<b>Sound Power*</b>		
In fast recirculation mode	79.9 dB(A)	
Measure at 2500 psi (17 MPa, 172 bar), 1 gpm (3.8 lpm)	93.3 dB(A)	

Reactor E-10hp	US	Metric
<b>Fluid Outlets</b>		
ISO Side	-5 JIC male	
RES Side	-6 JIC male	
<b>Fluid Circulation Returns</b>		
ISO side	-5 JIC male	
RES side	-6 JIC male	
<b>Hose Markings</b>		
ISO side	Red	
RES side	Blue	
<b>Wetted Parts</b>		
Wetted parts on all models	Aluminum, stainless steel, carbon steel, brass, carbide, chrome, chemically resistant o-rings, PTFE, ultra-high molecular weight polyethylene	
<b>Notes</b>		
* Sound power measured per ISO-9614-2.		

All other brand names or marks are used for identification purposes and are trademarks of their respective owners.





# Graco Standard Warranty

Graco warrants all equipment referenced in this document which is manufactured by Graco and bearing its name to be free from defects in material and workmanship on the date of sale to the original purchaser for use. With the exception of any special, extended, or limited warranty published by Graco, Graco will, for a period of twelve months from the date of sale, repair or replace any part of the equipment determined by Graco to be defective. This warranty applies only when the equipment is installed, operated and maintained in accordance with Graco's written recommendations.

This warranty does not cover, and Graco shall not be liable for general wear and tear, or any malfunction, damage or wear caused by faulty installation, misapplication, abrasion, corrosion, inadequate or improper maintenance, negligence, accident, tampering, or substitution of non-Graco component parts. Nor shall Graco be liable for malfunction, damage or wear caused by the incompatibility of Graco equipment with structures, accessories, equipment or materials not supplied by Graco, or the improper design, manufacture, installation, operation or maintenance of structures, accessories, equipment or materials not supplied by Graco.

This warranty is conditioned upon the prepaid return of the equipment claimed to be defective to an authorized Graco distributor for verification of the claimed defect. If the claimed defect is verified, Graco will repair or replace free of charge any defective parts. The equipment will be returned to the original purchaser transportation prepaid. If inspection of the equipment does not disclose any defect in material or workmanship, repairs will be made at a reasonable charge, which charges may include the costs of parts, labor, and transportation.

**THIS WARRANTY IS EXCLUSIVE, AND IS IN LIEU OF ANY OTHER WARRANTIES, EXPRESS OR IMPLIED, INCLUDING BUT NOT LIMITED TO WARRANTY OF MERCHANTABILITY OR WARRANTY OF FITNESS FOR A PARTICULAR PURPOSE.**

Graco's sole obligation and buyer's sole remedy for any breach of warranty shall be as set forth above. The buyer agrees that no other remedy (including, but not limited to, incidental or consequential damages for lost profits, lost sales, injury to person or property, or any other incidental or consequential loss) shall be available. Any action for breach of warranty must be brought within two (2) years of the date of sale.

**GRACO MAKES NO WARRANTY, AND DISCLAIMS ALL IMPLIED WARRANTIES OF MERCHANTABILITY AND FITNESS FOR A PARTICULAR PURPOSE, IN CONNECTION WITH ACCESSORIES, EQUIPMENT, MATERIALS OR COMPONENTS SOLD BUT NOT MANUFACTURED BY GRACO.** These items sold, but not manufactured by Graco (such as electric motors, switches, hose, etc.), are subject to the warranty, if any, of their manufacturer. Graco will provide purchaser with reasonable assistance in making any claim for breach of these warranties.

In no event will Graco be liable for indirect, incidental, special or consequential damages resulting from Graco supplying equipment hereunder, or the furnishing, performance, or use of any products or other goods sold hereto, whether due to a breach of contract, breach of warranty, the negligence of Graco, or otherwise.

## **FOR GRACO CANADA CUSTOMERS**

The Parties acknowledge that they have required that the present document, as well as all documents, notices and legal proceedings entered into, given or instituted pursuant hereto or relating directly or indirectly hereto, be drawn up in English. Les parties reconnaissent avoir convenu que la rédaction du présente document sera en Anglais, ainsi que tous documents, avis et procédures judiciaires exécutés, donnés ou intentés, à la suite de ou en rapport, directement ou indirectement, avec les procédures concernées.

# Graco Information

For the latest information about Graco products, visit [www.graco.com](http://www.graco.com).

**TO PLACE AN ORDER**, contact your Graco distributor or call to identify the nearest distributor.

**Phone:** 612-623-6921 **or Toll Free:** 1-800-328-0211 **Fax:** 612-378-3505

*All written and visual data contained in this document reflects the latest product information available at the time of publication.  
Graco reserves the right to make changes at any time without notice.*

*For patent information, see [www.graco.com/patents](http://www.graco.com/patents).*

Original instructions. This manual contains English. MM 332144

**Graco Headquarters:** Minneapolis  
**International Offices:** Belgium, China, Japan, Korea

**GRACO INC. AND SUBSIDIARIES • P.O. BOX 1441 • MINNEAPOLIS MN 55440-1441 • USA**

**Copyright 2013, Graco Inc. All Graco manufacturing locations are registered to ISO 9001.**

[www.graco.com](http://www.graco.com)